

Fort Collins Stormwater Criteria Manual

As adopted by the City Council of the City of Fort Collins, as referenced in
Section 26-500 of the Code of the City of Fort Collins

December 2018

DRAFT



Fort Collins Stormwater Criteria Manual

Preface

- 1.0 Authority**
- 2.0 Purpose**
- 3.0 Revisions and Updated Criteria**
- 4.0 Other Related Standards**
- 5.0 Abbreviations**
- 6.0 Definitions**
- 7.0 Commonly Used Units**

Chapter 1: Drainage Principles & Policies

- 1.0 Principles**
- 2.0 Policies**
- 3.0 References**

Chapter 2: Development Process Submittal Requirements

- 1.0 Overview**
- 2.0 Conceptual Reviews (CR) and Preliminary Design Reviews (PDR)**
- 3.0 Overall Development Plan (ODP) Submittal Requirements**
- 4.0 Project Development Plan (PDP) and Final Plan (FP) Submittal Requirements**
- 5.0 Other Application Types Process Requirements**
- 6.0 Erosion Control Material Requirements**
- 7.0 Floodplain Modeling Reports**
- 8.0 Variance Request Process**

Chapter 3: During & Post-Construction Requirements

- 1.0 Overview**
- 2.0 Erosion Control Inspections and Field Requirements**
- 3.0 Drainage Certification**
- 4.0 Drainage Certification Escrow**
- 5.0 Close-Out Process**

Chapter 4: Construction Control Measures

- 1.0 Introduction**
- 2.0 Scope of Applicability**
- 3.0 Erosion and Sediment Control**
- 4.0 Overview of Construction Control Measures**
- 5.0 Control Measure Selection and Planning**
- 6.0 Detailed Construction Control Measures**
- 7.0 Variances to Erosion Control Criteria**
- 8.0 Standard Erosion Control Notes**

Chapter 5: Hydrology Standards

- 1.0 Overview**
- 2.0 Runoff Methodologies**
- 3.0 Rational Method**
- 4.0 SWMM**

Fort Collins Stormwater Criteria Manual

Chapter 6: Detention

- 1.0 Overview
- 2.0 Water Quantity Detention
- 3.0 Detention Basin Components
- 4.0 Alternative Detention Facilities
- 5.0 References

Chapter 7: Water Quality

- 1.0 Overview
- 2.0 Four Step Process
- 3.0 BMP Selection
- 4.0 Water Quality Detention
- 5.0 Hydrologic Basis of the WQCV
- 6.0 Low Impact Development

Chapter 8: Grading

- 1.0 Site Grading Design
- 2.0 Detention Basin Grading Design
- 3.0 Landscaping
- 4.0 Drainage Easements

Chapter 9: Streets, Inlets & Conveyance

- 1.0 Overview
- 2.0 Street Drainage
- 3.0 Inlets
- 4.0 Storm Drain Systems
- 5.0 Swales
- 6.0 Use of Irrigation Ditches
- 7.0 Energy Dissipation and Erosion Protection

Chapter 10:

- 1.0 References

Appendix A:

Development Submittal Checklists

Appendix B:

Landscape Design Standards and Guidelines for Stormwater & Detention Facilities

Appendix C:

LID Implementation Manual

Appendix D:

Construction Control Measures - Guidance

Appendix E:

Construction Control Measures - Fact Sheets

Appendix F:

Construction Control Measures – Standard Notes

Preface

Contents

- 1.0 Authority 1
- 2.0 Purpose 1
- 3.0 Revisions and Updated Criteria..... 3
- 4.0 Other Related Standards..... 3
- 5.0 Abbreviations 3
- 6.0 Defined Terms..... 6
- 7.0 Commonly Used Units..... 18

1.0 Authority

Per City Code Section 26-500, the Fort Collins Stormwater Criteria Manual (or Manual) is adopted by reference. The Fort Collins City Council has adopted this version of the Manual by Ordinance No. XXX, 2018.

The Utilities Executive Director is empowered under City Code Sections 1-2 and 26-496 to delegate certain authority to staff for proper administration and enforcement of the requirements of the Manual.

2.0 Purpose

The purpose of the Fort Collins Stormwater Criteria Manual is to set forth the design guidelines and technical criteria to be utilized in the analysis and design of stormwater drainage systems. This Manual serves as the governing criteria for all stormwater improvements, public or private, that are designed and installed within Fort Collins and its Growth Management Area (GMA). The scope of this Manual does not include floodplain criteria, design for natural stream corridors or stream restoration design principles; rather, it focuses on development projects that are primarily carried out by the private sector.

This Manual replaces in their entirety the previously adopted “Fort Collins Amendments to the Urban Drainage and Flood Control District Criteria Manual” dated December 2011. This Manual also changes from a format making “amendments” to the Urban Drainage and Flood Control District Criteria Manual to a stand-alone document that incorporates all key design guidance and more effectively communicates the criteria for Fort Collins and its GMA.

This Manual utilizes much of the information included in the Urban Storm Drainage Criteria Manual published by the Urban Drainage and Flood Control District (UDFCD), old and new, and continues to recognize the UDFCD for its conducted research, data collection and development of analytical methods for the design and installation of stormwater infrastructure. The UDFCD Manual has become a common reference document for Fort Collins Utilities (FCU) staff and Design Engineers alike because of the design tools and spreadsheet capabilities. It has also become an industry standard reference for Low Impact Development (LID) information and design guidance. However, there are some criteria in the UDFCD Manual that are not applicable in Fort Collins and its GMA and do not meet the requirements set forth in this Manual. In addition, there are certain requirements that FCU continues to regulate by, that are set forth in this Manual, which are no longer fully addressed in the current UDFCD Manual.

In addition, this Manual recognizes the various Master Drainage Plans that have been developed for all the major drainage basins within and around Fort Collins. Each Master Drainage Plan provides detailed analysis and selected plan improvement guidance for major stormwater infrastructure needs throughout Fort Collins and its GMA, see **Figure 2.0-1** below. This Manual directs users to apply allowable release rates for storm drainage that have been established by the various Master Drainage Plans and to incorporate any selected plan improvements (where appropriate) into their design. This Manual does not provide direction or requirements for Master Drainage Plan updates.

Figure 2.0-1. Master Drainage Basin Map with City Limits and GMA

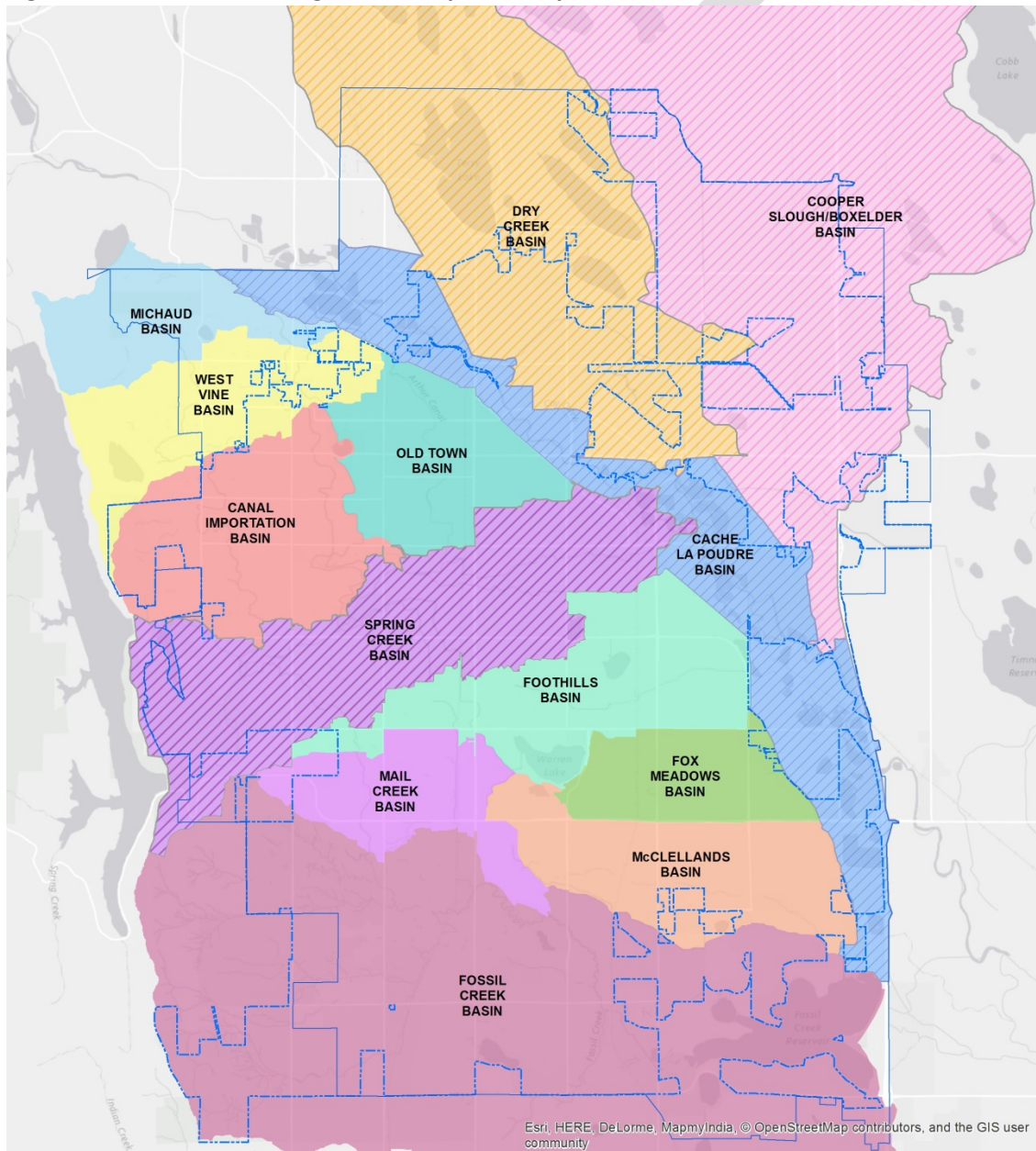

3.0 Revisions and Updated Criteria

This Manual may be amended, including but not necessarily limited to, when new technology is developed or as experience is gained in the use of the Manual. Amendments may be made administratively pursuant to City Code Section 26-500 or pursuant to City Council action. FCU will maintain this Manual and any amendments thereto and will post this Manual and amendments on the City's website (fcgov.com). FCU does not keep a database of holders of this Manual. It shall be the responsibility of each holder to verify the most current Manual is being used for any development.

4.0 Other Related Standards

- Chapter 26 of [City Code](#) and this Manual sets forth the minimum standards for designing stormwater infrastructure in Fort Collins.
- All public stormwater improvements shall comply with the conditions and regulations established in the applicable Master Drainage Plan(s).
- Materials and installation of stormwater improvements shall comply with the City of Fort Collins Water, Wastewater, Stormwater Development Construction Standards.
- The Planning Services in the Community Development and Neighborhood Services Department administers the Fort Collins [Land Use Code](#) which defines the various processes required for development projects within the City.
- Engineering Development Review administers the [Larimer County Urban Area Street Standards \(LCUASS\)](#) which set forth standards for certain public improvements within City right-of-way and public easements.

5.0 Abbreviations

BDR	Basic Development Review (as defined in the Land Use Code)
BMP	Best Management Practice
CDPHE	Colorado Department of Public Health and Environment
CDPS	Colorado Discharge Permit System

5.0 Abbreviations

CMP	Corrugated Metal Pipe
CR	Conceptual Review (as defined in the Land Use Code)
CRS	Colorado Revised Statutes
CWCB	Colorado Water Conservation Board
CWQCC	Colorado Water Quality Control Commission
CWQCD	Colorado Water Quality Control Division
DCIA	Directly Connected Impervious Area
DCP	Development Construction Permit
DRCOG	Denver Regional Council of Governments
EDB	Extended Detention Basin
EGL	Energy Grade Line
EPA	U.S. Environmental Protection Agency
FAA	Federal Aviation Administration
FCSCM	Fort Collins Stormwater Criteria Manual
FEMA	Federal Emergency Management Agency
FIRM	Flood Insurance Rate Map
FCU	Fort Collins Utilities
FP	Final Plan (as defined in the Land Use Code)
GMA	Growth Management Area
HGL	Hydraulic Grade Line

H:V	Horizontal to Vertical Ratio of a Slope
I	Percent Imperviousness of a Catchment
IDF	Intensity-Duration-Frequency curve
LCUASS	Larimer County Urban Area Street Standards
LID	Low Impact Development
MDCIA	Minimized Directly Connected Impervious Area
MS4	Municipal Separate Storm Sewer Systems
NAVD	North American Vertical Datum
NGVD	National Geodetic Vertical Datum
NPDES	National Pollutant Discharge Elimination System
NRCS	Natural Resources Conservation Services
ODP	Overall Development Plan (as defined in the Land Use Code)
PDP	Project Development Plan (as defined in the Land Use Code)
PDR	Preliminary Design Review (as defined in the Land Use Code)
PICP	Permeable Interlocking Concrete Pavers
PLD	Porous Landscape Detention (current vernacular is bioretention or rain garden)
PDR	Preliminary Design Review (as defined in the Land Use Code)
RCP	Reinforced Concrete Pipe
SCS	Soil Conservation Service (now the Natural Resources Conservation Service (NRCS))
SEO	Colorado State Engineer's Office

SOP	Standard Operating Procedure
SWMM	EPA Stormwater Management Model
UDFCD	Urban Drainage Flood Control District
USDCM	Urban Storm Drainage Criteria Manual published by UDFCD
USACE	United States Army Corps of Engineers
WQCV	Water Quality Capture Volume

6.0 Defined Terms

404 Permit: A federal discharge permit authorized under Section 404 of the Clean Water Act, which regulates the discharge of dredged, excavated, or fill material into wetlands, streams, rivers, and other Waters of the U.S. The U.S. Army Corps of Engineers is the federal agency authorized to issue Section 404 Permits for certain activities conducted in wetlands or other U.S. waters. When working in or around waterways or wetlands, 404 Permits are often required.

Adjacent: Having a common endpoint or bordering lot lines or parcels.

Area of Disturbance: Total area at the site where any Construction Activity is expected to result in disturbance of the ground surface. This includes any activity that could increase the rate of erosion, including but not limited to, clearing, grading, excavation, and demolition activities, installation of new or improved haul roads and access roads, staging areas, heavy vehicle traffic areas, stockpiling of fill materials, and borrow areas.

As-Builts: Refer to the definition for Record Drawings.

Best Management Practice (BMP): Best Management Practices is used interchangeably with the term Control Measure throughout this Manual. Refer to the definition of Control Measure.

Buffer Zone: Also referred to as a Natural Habitat Buffer Zone, a designated transitional area around a stream, lake, wetland, irrigation ditch or other natural habitat or feature left in a natural, usually vegetated state so as to protect the ecological character of the resource from impacts associated with development. Development is often restricted or prohibited in a buffer zone, pursuant to section 3.4.1 of the Fort Collins Land Use Code.

Building Permit: As defined in the Land Use Code

Certificate of Occupancy: As defined in the Land Use Code

City: Refers to the City of Fort Collins, a Colorado municipal corporation

City Code: Refers to the Fort Collins Municipal Code, as the same may be amended

Clean Water Act: Federal legislation that provides statutory authority for the National Pollutant Discharge Elimination System (NPDES) program and other water quality protection requirements; Public law 92-500; 33 U.S.C. 1251 et seq. Also known as the Federal Water Pollution Control Act. Under the Clean Water Act stormwater requirements, most urban areas must meet requirements of Municipal Separate Storm Sewer System (MS4) permits, and many industries and institutions such as state departments of transportation must also meet NPDES stormwater permit requirements. Operators of regulated MS4s are required to develop a Stormwater Management Plan (SWMP) that includes measurable goals and to implement needed stormwater management controls (BMPs). MS4s are also required to assess controls and the effectiveness of their stormwater programs and reduce the discharge of pollutants to the "maximum extent practicable."

Colorado Discharge Permit System (CDPS): The State of Colorado's system of permitting discharges (e.g., stormwater, wastewater) to Waters of the State that corresponds to the federal NPDES permits under the federal Clean Water Act.

Common Plan of Development or Sale: A contiguous area where multiple separate and distinct Construction Activities may be taking place at different times on different schedules, but remain related. The Water Quality Control Division within CDPHE, has determined that "contiguous" means Construction Activities located in close proximity to each other (within ¼ mile) as per CDPS General Permit on Construction Activity.

Construction Activity: As defined in CDPS State Stormwater Discharge Permit, with the following clarifications:

- Clearing shall include grubbing activities.
- Demolition shall not include demolition activities entirely comprised of interior demolition (as those should be considered remodel).
- Activities to conduct repairs that are not part of regular maintenance and activities that are for replacement are considered construction activities and are not considered routine maintenance.
- Repaving activities where underlying or surrounding soil is cleared, graded, or excavated as part of the repaving operation are construction activities unless they are excluded site under the MS4 General Permit.

- Construction activity occurs from initial ground breaking until the final stabilization regardless of ownership of the construction activities.

Construction Control Measure: Typically refers to structural and non-structural Temporary Control Measures during Construction Activities. In general, the Control Measures can be broken into groups around Erosion Control Measures, Sediment Control Measures, Site Management Controls (sometimes called administrative controls), and/or Materials Management Controls (sometime called source controls).

Construction Drawings: The plans or working drawings showing what is proposed to be built. These are typically referred to as Utility Plans in the City.

Control Measure: A technique, process, activity or structure used to reduce pollutant discharges in stormwater. Control measures include source control practices (non-structural control measures) and engineered structures (structural control measures) designed to treat runoff. Control measures are most effective when used in combination and selected and designed based on site-specific characteristics. Control measures can include but not be limited to schedules of activities, prohibitions of practices, maintenance procedures, and other management practices to prevent or reduce the pollution of waters of the State. Control measures also include treatment requirements, operating procedures, pollution prevention, and practices to control site runoff, spillage or leaks, waste disposal, or drainage from material storage. Control measures can be either temporary or permanent depending on the intended use. The term Control Measure has shown to be a more precise word and may be used in place of the more recognizable term Best Management Practices (BMPs).

Dedicated Asphalt Plants and Concrete Plants: Portable asphalt or concrete plants that are located on or adjacent to a construction site and that provide materials only to that specific construction site.

Design Engineer: Refers to the person(s) in responsible charge of formulating the design, analysis, reporting and Construction Plans for a project.

Detention Basin, Facility or Pond: The temporary capture and slow release of stormwater from an excavated area, enclosed depression or tank. Detention is used for pollutant removal and stormwater peak flow reduction. Detention basins, facilities and ponds are considered to be “stormwater detention and infiltration facilities” under CRS §37-92-602(8).

Development: As defined in the Land Use Code

Developer: As defined in the Land Use Code.

Development Agreement: As defined in the Land Use Code.

Development Review Guide: A [flowchart](#) outlining the development review process for the City.

Disturbed Area: Refer to the definition for Area of Disturbance.

Distributed Controls: The use of multiple control measures distributed throughout a development site to control and treat stormwater close to its source as opposed to routing flows to a larger, centralized stormwater facility. Use of distributed stormwater controls is a key component of Low Impact Development. Distributed Controls may also commonly be referred to as a Treatment Train.

Drainage Certification Escrow: Money collected by the City when the Developer wishes to obtain the Certificate of Occupancy for the project prior to the full completion of all site improvements and/or submittal and acceptance of the drainage certification. The amount of escrow is determined based on the amount of improvements yet to be installed when the Certificate of Occupancy is requested.

Drainage Report: A written narrative and analysis documentation that includes existing condition stormwater runoff information and proposed condition stormwater runoff information; and includes the design of a stormwater infrastructure system that is equipped to handle the proposed stormwater runoff condition. The drainage report will show how the proposed design meets the requirements of this Manual. This report generally accompanies other development submittal documents or plans. Final reports are to be submitted on 8 ½ x 11 standard paper, bound, and stamped, signed and dated by the Professional Engineer in responsible charge of the report. The requirements of the Drainage Report are discussed in Chapter 2: Development Submittal Requirements of this Manual.

Easement: An interest in land owned by another person, consisting of the right to use or control the subject land, or an area above or below it, for specific limited purposes.

Emergency Work: Work to address an issue that could potentially cause health and safety impacts to the community if not acted upon immediately. These are typically actions that have little to no planning availability. These activities, on a small scale, are exempt. However, if a disturbance of greater than an acre will occur planning will need to happen in accordance with the City's MS4 Permit.

Endangered Species Act: The federal Endangered Species Act of 1973 protects animal and plant species currently in danger of extinction (endangered) and those that may become endangered in the foreseeable future (threatened). It provides for the conservation of ecosystems upon which threatened and endangered species of fish, wildlife, and plants depend, both through federal action and by encouraging the establishment of state programs.

Erosion: The process by which soil particles are detached and transported from the point of origin by wind, water, and gravity.

Erosion Control Administrator: The person who is responsible for all erosion control activities on the site. This person oversees or conducts activities, installation, maintenance, removal and inspection of the control measures on the site that will ensure the site is, at all times, in compliance with the various permits. This person is responsible for keeping the permit documents up to date. This person will proactively correct issues and work to get site issues identified and resolved to ensure that the site is not discharging pollutants offsite. This is identical to a SWMP Administrator on the State Stormwater Discharge Permit.

Erosion Control Criteria: All criteria set forth in any part of the Manual that relate to erosion, sediment, and pollution control. Typically the standards set out in the Construction Control Measures Chapter of this Manual and the guidance material located in the Appendices.

Erosion Control Escrow: A predetermined calculation or estimation of money that will be required, collected, and retained to ensure the Developer will complete all activities on the project without discharging pollutants from the site. This escrow is collateral to have the City correct issues in the field if the Developer cannot or will not fulfill required erosion control activities in a timely manner.

Erosion Control Material: The combinations of any planning materials used to convey how the project will prevent pollutant discharges to the maximum extent practicable. This typically includes the Erosion Control Plans that are part of the Utility Plans, an Erosion Control Report and an Erosion Control Escrow.

Erosion Control Measures: Source controls used to limit erosion of soil at construction sites and other erosion-prone areas. Representative measures include surface treatments that stabilize soil that has been exposed due to excavation or grading and flow controls that redirect flows or reduce velocities of concentrated flow.

Erosion Control Plan: A map or schematic information that gives a blue print to how to prevent pollutant discharges from the construction site.

Erosion Control Report: A written narrative describing the project and the protective actions, erosion and sediment control measures, site and materials management control measures proposed for the construction process at a particular site. The requirements of an Erosion Control Report are discussed in Chapter 2: Development Submittal Requirements of this Manual.

Established Vegetation: Refer to the definition for Final Stabilization.

Extended Detention Basin: A basin that is constructed in an excavated or depressed area that provides the temporary detention and slow release of stormwater while also promoting the settlement of pollutants. Extended detention basins are typically designed as a multi-stage facility that provides attenuation for both stormwater quantity and quality.

Final Stabilization: Condition reached when all ground surface disturbing activities at the site have been completed, and for all areas of ground surface disturbing activities, a uniform vegetative cover has been established with a vegetative cover (individual plant density) of at least 70 percent, or equivalent permanent, physical erosion reduction methods have been employed. See Chapter 4: Construction Control Measures, for more information.

First Design Point: The most upstream point in drainage analysis.

Fort Collins: Lands located within the municipal boundaries of the City of Fort Collins

Fort Collins Utilities: Those departments of Utility Services which are in charge of the stormwater facilities for the City.

Grass Buffer: Uniformly graded and densely vegetated area, typically as turf grass. This control measure requires sheet flow to promote filtration, infiltration, and settling to reduce runoff pollutants, and per state guidance, need to accompany at least one other control measure in a treatment train. Grass Buffers are not the same as the Vegetated Buffer that is identified in the LID Implementation Manual and are not allowed to be considered LID.

Green Infrastructure: Planning and design of systems intended to benefit from the services and functions provided in the natural environment. In regard to wet weather management, and on a regional scale, preservation of riparian floodplains and channel stabilization that allows for vital habitat and wildlife passage through techniques similar to those found in nature, preserves ecological function and creates balance between built and natural environments. On an urban level, wet weather management practices that include infiltration help restore natural hydrology.

Illicit Discharge: A discharge to a municipal separate storm sewer (MS4) that is not composed entirely of stormwater and is not authorized by a NPDES permit, with some exceptions (e.g., discharges due to firefighting activities).

Impervious Area: A hard surface area (concrete or asphalt surface or rooftop surface) that prevents or retards the infiltration of water into the soil.

Infiltration: The percolation of water from the land surface into the ground.

Inlet: An entry into a storm sewer system, ditch or other waterway.

Land Use Code: Refers to the City of Fort Collins Land Use Code.

Larger Common Development: Refer to the definition for Common Plan of Development or Sale.

Level Spreader: An engineered structure designed to convert concentrated runoff to sheet flow and disperse it uniformly across a slope, thereby preventing/minimizing erosion.

Local Facility: Refers to a stormwater facility, typically a detention or water quality pond that services private development. These are typically owned and maintained by the property owner or HOA.

Low Impact Development (LID): LID is a comprehensive land planning and engineering design approach to managing stormwater runoff with the goal of mimicking the pre-development hydrologic regime. LID emphasizes conservation of natural features and the use of engineered, onsite, small-scale hydrologic controls that filter, infiltrate, evaporate and detain runoff close to its source to protect stormwater quality. The term Green Infrastructure (GI) may also be used.

Manual: The current Fort Collins Stormwater Criteria Manual adopted pursuant to §26-500, and be applicable to stormwater infrastructure and management, operation and maintenance of stormwater improvements, together with any technical revisions thereto, as more specifically described in §26-500.

Master Drainage Basin: Regional and individual drainage basins or watersheds. In the Fort Collins area, there are twelve different master drainage basins: Cache La Poudre, Dry Creek, Cooper Slough/Boxelder, West Vine, Old Town, Canal Importation, Spring Creek, Foothills, Mail Creek, Fox Meadows, McClellands and Fossil Creek.

Master Drainage Plan: A plan for a Master Drainage Basin that provides guidance for stormwater infrastructure improvements and also dictates site requirements for development sites.

Materials Management Controls Practices: A variety of practices implemented to limit or remove pollutant source contact with runoff thereby minimizing pollutant transport in runoff. Representative materials management controls include good housekeeping measures, landscape management practices, pet waste controls, public education regarding household hazardous waste, and/or covering outdoor storage areas. Some examples of such practices are relocating construction materials and equipment-related fluids, or by intentionally controlling and managing areas where chemicals are handled mixed and stored.

Minimizing Directly Connected Impervious Area (MDCIA): MDCIA includes a variety of runoff reduction strategies based on reducing impervious areas and routing runoff from impervious surfaces over grassy areas to slow runoff and promote infiltration. MDCIA is recommended as a key technique for reducing runoff peaks and volumes for frequently-occurring storms following urbanization. MDCIA is a key component of LID.

Modified FAA: The Federal Aviation Administration method to sizing small detention basins that is a volume-based approach and is sensitive to the release rate. “Modification” of the FAA method derives the average release from the allowable peak outflow.

Modified Impervious Area: Existing impervious areas on an existing site being removed and replaced with new impervious surfaces (e.g. existing asphalt surface becoming a rooftop surface) through a redevelopment process. Mill and overlay of asphalt areas is not considered a “modified” impervious area.

Municipal Separate Storm Sewer System (MS4): A publicly owned (state, city, town, county, district or other public body created by state law) having jurisdiction over disposal of sewage, industrial waste, stormwater or other wastes; design or used for collecting, conveyance or system of conveyances (including roads with drainage systems, municipal streets, catch basins, curbs, gutters, ditches, manmade channels or storm drains) that discharges to water of the U.S. and is designed or used for collecting or conveying stormwater, is not a combined sewer, and is not part of a publicly owned treatment works (POTW).

MS4 Permit: A state or federal stormwater discharge permit to regulate discharges from municipal separate storm sewers (MS4s) for compliance with Clean Water Act regulations.

MS4 Permitted Areas: An area that is marked in the MS4 permit to allow stormwater discharge from the areas.

National Pollutant Discharge Elimination System (NPDES): The national program under Section 402 of the Clean Water Act for regulation of discharges of pollutants from point sources to waters of the U.S.

Operator: Entity that has day-to-day supervision and control of activities occurring at the construction site. This can be the owner, the developer, the general contractor or the agent of one of these parties. It is anticipated that at different phases of a construction project, different types of parties may satisfy the definition of the Operator and that all applicable permits may be transferred as the roles change.

Outfall: The point or location where stormwater leaves the site and discharges into a receiving water or a stormwater collection system.

Owner: As defined in the City Code, Section 26-1.

Peak Runoff Rate: The highest actual or predicted flow rate for runoff from a site for a specific storm event, typically measured in cubic feet per second (cfs).

Pervious Area: A soft surface that promotes the infiltration of water into the soil, thus reducing water runoff from the surface.

Phasing: A division of geographical areas on a site or parts of the whole project that will be constructed in different schedules.

Pollutant: As defined in City Code Section 26-491.

Pollutant Load: The mass of pollutants carried in runoff, calculated based on flow volume multiplied by pollutant concentration. Pollutant loading has units of mass and is calculated over specific timescales such as day, month or year.

Professional Engineer: As defined in C.R.S. §12-25-102

Public Hearing: An official and properly-noticed meeting of a governmental body that is open to the public, during which arguments and evidence regarding a matter are presented to the governmental body pursuant to applicable rules for the hearing.

Rainfall Erodibility: A description of the potential of sediment to be suspended into runoff and transported away from its origin based upon the soil characteristics and properties.

Receiving Waters: Any classified stream segment (including tributaries) in the State of Colorado into which stormwater related to Construction Activities may discharge. This definition includes all water courses, even if they are ephemeral or usually dry, including but not limited to, borrow ditches, arroyos, and other unnamed waterways. In Fort Collins, receiving waters all directly or eventually discharge to the Poudre River or Fossil Creek Reservoir, which itself discharges to the Poudre River.

Record Drawings: A set of drawings reflecting the changes made to the working drawings or construction drawings during the construction process and show corrected dimensions, geometry and locations of all elements of the work; sometimes referred to as “as-builts”.

Re-development: Improvements to an existing developed area, typically involving removal of existing structures and construction of new buildings and associated infrastructure.

Regional Facility: Refers to a stormwater facility, typically a detention or water quality pond that services a regional area.

Retention Pond: A depression in the ground that holds a permanent pool of water. Retention ponds typically have very minimal or zero water release by gravity. Retention ponds are not allowed to serve as water quantity or quality control measures for any development within the City or its GMA.

Right-of-Way: Lands subject to public use for transport, such as streets and sidewalks. The use of the term right-of-way in the Manual shall be the same as that term is used in the City Code and Land Use Code.

Sediment: The accumulation of displaced soil particles that have been transported by wind, water, and gravity to a downslope or downstream location.

Sediment Control Measures: Practices that reduce transport of sediment offsite to downstream properties and receiving waters. Sediment controls generally either provide filtration through a permeable media or slow or detain runoff to allow settling of suspended particles.

Sensitive Areas: Areas that typically include floodplains, slopes, riparian corridors, lakes, irrigation ditches, or other features subject to natural areas buffer requirements. Refer to the Land Use Code Section 3.4.1.

Sequencing: A division of Construction Activities in one area that will progress chronologically from start to finish. Refer to the CDPHE definition of Phasing.

Sheet Flow: The portion of precipitation that flows overland in very shallow depths before reaching a concentrated flow conveyance or stream channel.

Site Management Controls: A combination of construction and administrative practices that help reduce pollutants leaving a construction site. Site Management Controls are typically a non-structural Control Measure that is planning and/or timed to minimize pollutant exposure and discharge. These include practices such as construction sequencing and scheduling, vehicle tracking controls and street sweeping, good management of practices associated with site construction such as stream crossing, temporary batch plants, dewatering operations and other measures. An example of using a site management control would be working in winter, as compared to summer, along a flood bank because the timing of a winter project would reduce the potential for pollutant loading.

Soils Report: Refers to a geotechnical report.

Source Controls: A variety of practices implemented to minimize pollutant transport in runoff by controlling pollutants where they originate and/or accumulate. Representative source controls include good housekeeping measures, landscape management practices, pet waste controls, public education regarding household hazardous waste, covering outdoor storage areas, etc.

Stage-Storage: The relationship between stage, or elevation, in a detention basin to the amount of volume contained in a detention basin.

State Stormwater Discharge Permit: A permit issued by CDPS issued to allow discharges to the state waters. Typically the "General Permit for Stormwater Discharges associated with Construction Activity".

Steep slopes: Any slopes that have a steeper incline than three to one (3H: 1V).

Storage: This term is used in this Manual to reflect common industry terminology; however, none of the stormwater operations discussed herein are intended to constitute "storing" or the "storage" of water as that term is defined in CRS §37-92-103(10.8) and used in the context of water rights.

Storm Event (for erosion control inspection purposes): A site condition where stormwater causes surface erosion and has the potential to suspend pollutants and impact stormwater. While this potential can occur during any rain event based upon many factors, this guideline is typical of the "water quality storm" as defined by the Water Quality Capture Volume or a storm lasting longer than 30 minutes.

Stormwater: Precipitation or other meteorological conditions that transports water to an area. Stormwater includes runoff, which is water from rain, snowmelt or irrigation that flows over the land surface.

Stormwater Management Plan (SWMP): A written plan required under state and federal stormwater discharge permits identifying measures that will be implemented to minimize the discharge of pollutants in stormwater. Requirements for SWMPs are legally specified in state and federal discharge permits. Requirements vary depending on whether the discharge permit is associated with municipal, industrial, or Construction Activities.

Surface Water: Water that remains on the surface of the ground including rivers, lakes, reservoirs, streams, wetlands, impoundments, seas, estuaries, etc.

Treatment Train: Control measures that work together in series to provide stormwater quality treatment. See Distributed Controls.

Utilities Executive Director: Refers to the Utilities Executive Director or appointed designee(s).

Utility Plans: Refers to construction plans or drawings.

Vegetative Cover: Density or thickness of vegetation covering the soil.

Water Quality Capture Volume (WQCV): This volume represents runoff from frequent storm events such as the 80th percentile runoff-producing event. The volume varies depending on local rainfall data. Within the UDFCD boundary, the WQCV is based on runoff from 0.6 inches of precipitation. This quantity also applies in Fort Collins.

Waters of the State (of Colorado): Same as “State Waters” as defined in the Colorado Water Quality Act at CRS §25-8-103(19) as: any and all surface waters and subsurface waters which are contained in or flow in or through this state, but does not include waters in sewage systems, waters in treatment works of disposal systems, waters in potable water distribution systems, and all water withdrawn for use until use and treatment have been completed. This definition can include water courses that are usually dry (typically associated to state issued permits.)

Waters of the United States: Waters that are subject to the federal Clean Water Act (typically associated with federal issued permits.)

Watershed: A geographical area that drains to a specified point on a water course, usually a confluence of streams or rivers (also known as drainage basin, catchment or river basin)

Wind Erodibility: A description of the potential for sediment to be suspended in the air and transported away from its origin based upon the soil characteristics and properties.

7.0 Commonly Used Units

cfs	cubic feet per second
cfs/ft	cubic feet per second per foot
ft	foot or feet
ft ²	square feet
ft ³	cubic feet
ft/ft	foot per foot
fps or ft/sec	feet per second
ft/sec ²	feet per second squared
hr	hour
in	inch
in/hr	inches per hour
in/hr/ac	inches per hour per acre
lbs	pounds
lbs/ft ²	pounds per square foot
lbs PLS/acre	pounds pure live seed per acre
min	minimum
psi	pounds per square inch
psf	pounds per square foot

Chapter 1: Drainage Principles & Policies

Contents

- 1.0 Principles 1
- 2.0 Policies 4
 - 2.1 Implementation of the Criteria in this Manual 4
 - 2.2 Drainage Planning 5
 - 2.2.1 Planning Process Elements 5
 - 2.2.2 Master Planning 6
 - 2.2.3 Drainage and Required Space 8
 - 2.2.4 Development and Site Planning 8
 - 2.2.5 Development and Site Planning for Offsite Flows 9
 - 2.2.6 Multiple-Objective Considerations 10
 - 2.2.7 Avoiding the Transfer of Problems 11
 - 2.2.8 Managing Runoff from Frequently Occurring Storms 11
 - 2.2.9 Watershed Approach to Stormwater Management 12
 - 2.3 Technical Criteria 13
 - 2.3.1 Determining Runoff Magnitude 13
 - 2.3.2 Detention Basins 13
 - 2.3.3 Retention Ponds 14
 - 2.3.4 Municipal Separate Storm Sewer System (MS4) Permit 14
 - 2.3.5 Water Quality 16
 - 2.3.6 Four Step Process to Minimize Adverse Impacts of Urbanization 16
 - 2.3.7 Low Impact Development 17
 - 2.3.8 Use of Streets 17
 - 2.3.9 Open Channels 18
 - 2.3.10 Use of Irrigation Ditches and Reservoirs 18
 - 2.3.11 Erosion and Sediment Control 19
 - 2.3.12 Maintenance 20
 - 2.3.13 Floodplain Regulations 21

1.0 Principles

The purpose of this Manual is to promote the health, safety, welfare, and property of the City of Fort Collins and citizens through the proper control and treatment of stormwater, whether above or below surface; and, to ensure uniformity in performance with respect to design and construction of all drainage facilities.

The UDFCD includes a list of principles for drainage planning in the UDFCD Manual that has served as a guide for formulating its technical criteria for almost 50 years. Many of these principles are included in this Manual because these same philosophies have provided guidance and direction for the City's Master Drainage Plans, policies and design criteria that aim to protect the public and the environment, space planning requirements for new development, encouragement of responsible development as it relates to storm drainage infrastructure design, and Low Impact Development principles. The following UDFCD principles are included herein and adopted by the City:

Adequate drainage for urban areas is necessary to preserve and promote the general health, welfare and economic well-being of the region. Drainage is a regional feature that affects all governmental jurisdictions and all parcels of property.
(UDSCM, 2016)

- 1) ***Drainage is a regional phenomenon that does not respect the boundaries between government jurisdictions or between properties. This makes it necessary to formulate programs that include both public and private involvement. Overall, the governmental entities most directly involved must provide coordination and master planning, but drainage planning must be integrated on a regional level if optimum results are to be achieved. The manner in which proposed drainage systems fit into existing regional systems must be quantified and discussed in the master plan.***
- 2) ***A storm drainage system is a subsystem of the total urban water resource system. Stormwater system planning and design for any site must be compatible with comprehensive regional plans and should be coordinated with planning for land use, open space and transportation. Erosion and sediment control, flood control, site grading criteria, and water quality all closely interrelate with urban stormwater management. Any individual master plan or specific site plan should normally address all of these considerations.***

- 3) **Every urban area has an initial (i.e., minor) and a major drainage system, whether or not they are actually planned and designed.** The initial drainage system, sometimes referred to as the “minor system,” is designed to provide public convenience and to accommodate moderate, frequently occurring flows. The major system carries more water and operates when the rate or volume of runoff exceeds the capacity of the minor system. Both systems should be carefully considered.
- 4) **Runoff routing is primarily a space allocation problem.** The volume of water present at a given point in time in an urban region cannot be compressed or diminished. Channels and storm drains serve both conveyance and detention functions. If adequate provision is not made for drainage space demands, stormwater runoff will conflict with other land uses, result in damages, and impair or disrupt the functioning of other urban systems.
- 5) **Planning and design of stormwater drainage systems should not be based on the premise that problems can be transferred from one location to another.** Urbanization tends to increase downstream peak flow by increasing runoff volumes and velocities. Stormwater runoff can be temporarily captured and slowly released via detention facilities to manage peak flows, thereby reducing the drainage capacity required immediately downstream.
- 6) **An urban storm drainage strategy should be a multi-objective and multi-means effort.** The many competing demands placed upon space and resources within an urban region argue for a drainage management strategy that meets a number of objectives, including water quality enhancement, groundwater recharge, recreation, wildlife habitat, wetland creation, protection of landmarks/amenities, control of erosion and sediment deposition, and creation of open spaces.
- 7) **Design of the storm drainage system should consider the features and functions of the existing drainage system.** Every site contains natural features that may contribute to the management of stormwater without significant modifications. Existing features such as natural streams, depressions, wetlands, floodplains, permeable soils, and vegetation provide for infiltration, help control the velocity of runoff, extend the time of concentration, filter sediments and other pollutants, and recycle techniques that preserve or protect and enhance the natural features are encouraged. Good designs improve the effectiveness of natural systems rather than negate, replace or ignore them.

- 8) ***In conjunction with new development and redevelopment, coordinated efforts should be made to minimize increases in, and reduce where possible, stormwater runoff volumes, flow rates, and pollutant loads to the maximum extent practicable. Key practices include:***
- a. *The perviousness of the site and natural drainage paths should be preserved to the extent feasible. Areas conducive to infiltration of runoff should be preserved and integrated into the overall runoff management strategy for the site.*
 - b. *The rate of runoff should be slowed. Preference should be given to stormwater management systems that maximize vegetative and pervious land cover. These systems will promote infiltration, filtering and slowing of the runoff. It should be noted that, due to the principle of mass conservation, it is virtually impossible to prevent increases in post-development runoff volumes for all storm events when an area urbanizes. Peak flows must be controlled to predevelopment levels. Increases in runoff volumes are managed to minimize adverse impacts on stream stability.*
 - c. *Pollution control is best accomplished by implementing a series of measures, which can include source controls, minimizing directly connected impervious area, and construction of on-site and regional facilities to control both runoff and pollution. Implementing measures that reduce the volume of runoff produced by frequently occurring events through infiltration and disconnection of impervious areas is one of the most effective means for reducing the pollutant load delivered to receiving waters.*
- 9) ***The stormwater management system should be designed beginning with the outlet or point of outflow from the project, giving full consideration to downstream effects and the effects of offsite flows entering the system. The downstream conveyance system should be evaluated to ensure that it has sufficient capacity to accept design discharges without adverse upstream or downstream impacts such as flooding, stream bank erosion, and sediment deposition. In addition, the design of a drainage system should take into account the runoff from upstream sites, recognizing their future development runoff potential (e.g., imperviousness).***
- 10) ***The stormwater management system requires regular maintenance. Failure to provide proper maintenance reduces both the hydraulic capacity and pollutant removal efficiency of the system. The key to effective maintenance is clear assignment of responsibilities to an established entity (e.g., private property owner or HOA, local jurisdiction) and a regular schedule of inspections to determine maintenance needs and to ensure that required maintenance is conducted. Maintenance requirements of onsite drainage infrastructure should be a consideration when selecting specific design criteria for a given site or project.***

2.0 Policies

Principles are made operational through a set of policy statements. These include direction on how to implement these criteria, planning for stormwater drainage, and an overview of the technical criteria covered in this Manual.

2.1 Implementation of the Criteria in this Manual

The criteria set forth in this Manual applies to all land disturbing activities defined as Development by the Land Use Code or otherwise regulated by the City, including but not limited to, activities on private land, public rights-of-way, easements dedicated for public use, private roads and to all privately, publicly, and quasi-publicly owned and maintained facilities. All public or private storm drainage facilities regulated by the City must be planned and designed in accordance with the standards and criteria set forth in this Manual.

These criteria, with all future amendments, establish minimum design standards for providing and maintaining stormwater drainage systems. Should a conflict arise between the City Code, the Land Use Code or other City adopted standards and requirements, including but not limited to this Manual, City Code and the Land Use Code will govern.

The Manual may be periodically revised and amended, either by approval of the City Council or by technical revision approved by the Utilities Executive Director in accordance with City Code Section 26-500, as new technology is developed and experience is gained in the use of the Manual.

Adherence to the criteria in this Manual does not remove the Design Engineer or Developer's responsibility to investigate and obtain any other regulatory permits or approvals from local, regional, state and/or federal agencies that may be required for a particular project.

Before commencing design of any project, comprehensive facts and data should be collected and examined for the particular watershed and area under consideration, and the basis for the design should then be agreed upon by the governmental entities affected.

The Design Engineer is responsible for compliance with this Manual as well as other applicable design and construction standards in the preparation of engineering and construction documents for review and acceptance by FCU. The provisions of this Manual are minimum requirements that do not preclude the use of more restrictive or enhanced standards by the Design Engineer. The review and approval of any submitted plans by the City does not imply responsibility by FCU for accuracy or correctness of the plans.

Consequently, pursuant to the procedures of this Manual, when the Utilities Executive Director determines that an applicant has made a sufficient showing that an alternate design, analysis or

procedure would meet the purposes of a specific requirement of this Manual in a manner and to an extent equal to or better than compliance with the specific requirement the Utilities Executive Director may authorize a variance to the standard to allow for the use of the alternative design, analysis or procedure, as applicable. The variance request process is set forth in Chapter 2: Development Submittal Requirements.

2.2 Drainage Planning

Storm drainage is a part of the total urban environmental system. Therefore, storm drainage planning and design must be compatible with comprehensive regional plans. Master plans for storm drainage have been developed for this region and are maintained at FCU offices.

The planning for drainage facilities should be coordinated with planning for open space and transportation. By coordinating these efforts, new opportunities may be identified that can help solve drainage problems. Natural streams should be used to convey storm runoff whenever feasible. Major consideration must be given to the floodplains and open space requirements of the area. (White 1945)

All planned public or private improvements, or any other proposed construction or development activities regulated by the City must include an adequate plan for storm drainage. This plan must be based on an analysis and design in compliance with all the applicable requirements set forth in this Manual.

To provide for orderly urban growth, reduce costs to future generations and avoid loss of life and major property damage, both the initial drainage and the major drainage system must be properly planned, engineered and maintained.

Runoff from small, frequently occurring storms should be managed to reduce runoff peak flows, volumes (where feasible and pursuant to legal requirements)

and pollutant loading to streams. Management of these frequently occurring events helps to protect beneficial uses of streams and promotes channel stability.

The detention of runoff can reduce the drainage conveyance capacity requirement immediately downstream. Acquisition of open space adjacent to streams provides areas where storm runoff can spread out for slower delivery downstream.

2.2.1 Planning Process Elements

- 1) **Major Drainage Planning:** Local and regional planning should consider the major drainage system necessary to manage the 100-year runoff; that is the runoff having a one percent

- (1%) probability of occurrence in any given year. Implementation of major drainage plans will reduce loss of life and major damage to the community and its infrastructure.
- 2) **Outfall System Planning:** Outfall system planning efforts identify detention, water quality and conveyance practices within a watershed that ultimately discharges to a receiving stream. Outfall system plans typically address storm drain improvements, stream crossing improvements, stream enlargement, stabilization, and floodplain preservation.
 - 3) **Initial Drainage System Planning:** All local and regional planning should consider the initial drainage system to transport the runoff from the 2-year storm; this storm has a 50% probability of occurrence in any given year. The planner of an initial system must strive to minimize future drainage problems from these more frequently occurring storms.
 - 4) **Water Quality and Environmental Design:** All planning efforts should address stormwater quality treatment requirements, opportunities for the development to mimic natural hydrology and preserve natural features, enhance habitat, and evaluate impacts of new facilities. When convened early in the planning and design process, a multi-disciplinary design team can help to ensure that the benefits to total urban systems are considered in the drainage planning effort. For large-scale, multi-phase developments, planners and engineers should incorporate space for water quality treatments in the initial, overall design plans and plan ahead for addressing the water quality requirements, whether meeting all the requirements in the first phase or each phase meeting the requirements individually.
 - 5) **Long-term Maintenance and Operation:** Future operation and maintenance by private and public entities needs to be considered.

2.2.2 Master Planning

The Fort Collins area is divided into twelve regional and individual drainage basins. These are: **Cache La Poudre, Dry Creek, Cooper Slough/Boxelder, West Vine, Old Town, Canal Importation, Spring Creek, Foothills, Mail Creek, Fox Meadows, McClellands and Fossil Creek.** The City of Fort Collins has developed Master Drainage Plans for each of these individual drainage basins which will guide or dictate site requirements for development sites as well as establish any needed public improvements. Development within individual basins shall be required to meet the specifications of the Master Drainage Plan for the given area.

Proposed drainage systems design and construction must comply with all requirements set forth in the pertinent Master Drainage Plan for the area. The criteria specified in the appropriate Master Drainage Plan will hold precedence over the criteria set forth in this Manual in the event these differ or conflict.

Master Drainage Plans are developed in cooperation with Larimer County, affected ditch and reservoir companies and other affected governmental agencies within the given basin or basins. These plans are

adopted only after they have been reviewed by all affected entities and after soliciting public input. Master Drainage Plans are updated periodically when new information or updating basin conditions warrant it. These updates are also conducted in cooperation with all affected entities.

Figure 2.2.2-1. Master Drainage Basins

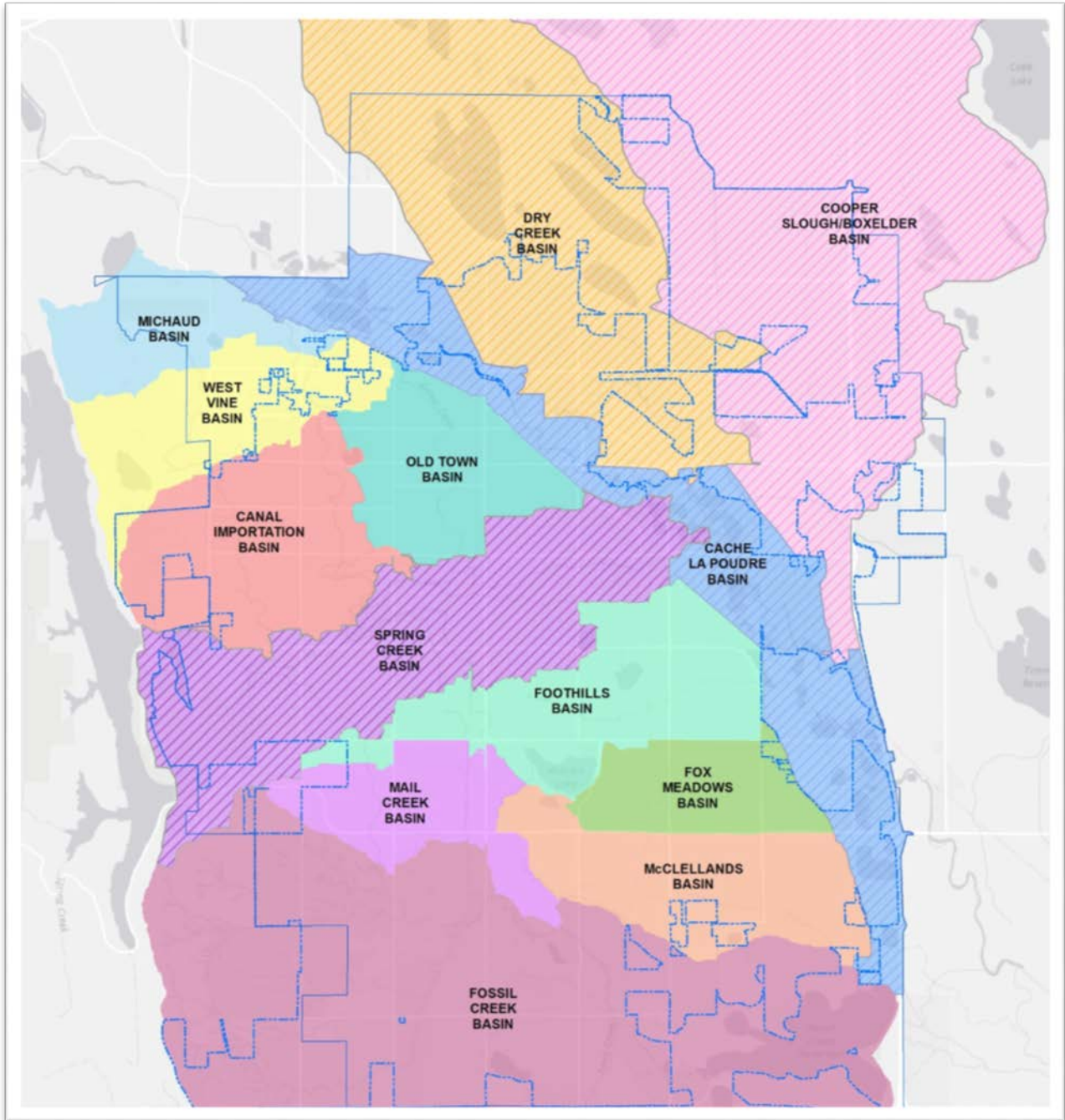

[Reference:](#) Master Drainage Plans are available at the Fort Collins Utility Services Center.

2.2.3 Drainage and Required Space

The stormwater drainage system is an integral part of the urbanization process; and requires storm drainage planning for all developments to include the allocation of space for drainage facilities' construction and maintenance which may entail the dedication of easements.

Drainage facilities, such as channels, storm pipes and detention facilities serve conveyance, treatment, as well as detention functions for water quantity and quality. When space requirements are considered, the provision for adequate drainage becomes a competing use for space. Therefore, adequate provision must be made in the land use plan for drainage space requirements. This may entail the dedication of adequate easements, in order to minimize potential conflict with other land uses.

These goals have the potential to influence the type of drainage subsystem selected. Planning for drainage facilities should be related to the goals of the urban region, should be looked upon as a subsystem of the total urban system and should not proceed independent of these considerations (Wright 1967).

2.2.4 Development and Site Planning

All land development proposals should receive full site planning and engineering analyses. In this regard, consideration must be given to the criteria outlined in this Manual. A development plan should consider broad goals such as:

- Drainage and flood control problem alleviation
- Economic reasonableness
- Broader regional development context
- Environmental preservation and enhancement, considering water quality, stream stability and natural resource protection (e.g. wetlands)
- Social and recreational objectives
- Long-term maintenance of the drainage systems

Flood control facilities, as planned by the City or Developers, are an integral part of the total drainage system required to preserve and promote the general health, welfare, and economic well-being of the area.

Planning for drainage facilities should be coordinated with planning for open space, recreation and transportation. By coordinating these efforts, new opportunities can be identified which can assist in the solution of drainage problems (Heaney, Pitt and Field 1999).

Regional flood control facilities are those that are operated and maintained by the City to benefit a regional area of a basin and the developments therein. Local flood control facilities are generally designed and constructed as a part of a private development project and are to be maintained and operated by the land owner. Any facility that is privately owned is required to enter into a Development Agreement with the City for maintenance requirements.

The City requires the planning and construction of all private local stormwater control and treatment facilities be performed in a manner that ensures that such facilities are compatible with all regional Master Drainage Plans including the City's Master Drainage Plans and the design requirements set forth in this Manual.

2.2.5 Development and Site Planning for Offsite Flows

Water naturally flows from up-gradient lands to down-gradient lands, without regard for land ownership boundaries. As discussed in this Manual, developments and other projects must plan for and consider water flows entering the subject property from up-gradient lands, and water flows leaving the subject property onto down-gradient lands in conformity with the City's Master Drainage Plans.

Up-gradient properties have been deemed to have legal and natural easements over down-gradient properties for the drainage of waters flowing in their natural course and manner. The owners of down-gradient properties thus generally have the corresponding obligation to accept the drainage of waters from up-gradient properties, provided that the up-gradient property owners have not overstepped their rights. A property owner may also generally re-route water within the property, provided that the property owner continues to abide by the various legal requirements with respect to the property being up-gradient to other properties, and down-gradient of others.

Water also naturally flows into channels, creeks, streams, and other naturally-occurring drainage ways. Whether or not these natural drainage ways are expressly dedicated or otherwise formally recognized for their drainage purposes, they are generally considered to be the best and most appropriate location of stormwater conveyance systems. They are also frequently recognized in the City's Master Drainage Plans.

When an up-gradient property develops (formally through the Development Review Process), specific drainage easements may be required on certain down-gradient properties, such as when the flows entering the down-gradient property are altered in quality or quantity or as to exceed the existing

drainage easements and potentially adversely affect the down-gradient property. Likewise, when a down-gradient property develops and up-gradient flows are draining onto the property, drainage easements may be required to allow for the continued conveyance of flows from the up-gradient site.

When drainage easements are required, the development is required to dedicate said easements to the City. Developments that affect or have an impact upon existing drainage easements must preserve and maintain those easements.

2.2.6 Multiple-Objective Considerations

Planning stormwater facilities should include consideration of multiple objectives, including the following:

- 1) **Lower Drainage Costs:** Planning drainage projects in conjunction with other urban needs results in more orderly development and lower costs for drainage and other facilities.
- 2) **Open Space:** Open space provides significant urban social, environmental and economic benefits. Use of stabilized, natural streams is often less costly than constructing artificial channels. Combining the open space needs of a community with the major drainage system is a desirable combination of uses that reduces land costs and promotes riparian zone protection and establishment over time.
- 3) **Transportation:** Design and construction of new streets and highways should be fully integrated with drainage needs of the urban area for better streets and highways and better drainages and to avoid creation of flooding hazards.
- 4) **Natural Drainage Ways:** Natural channels, creeks, streams and other naturally occurring drainage ways should be used in lieu of storm drains for stormwater runoff wherever practical. Preservation and protection of natural streams are encouraged; however, significant consideration must be given to minimize erosion as the tributary area urbanizes.
- 5) **Channelization:** Natural streams within an urbanizing area are often “channelized” (i.e. they could be deepened, straightened, lined, and sometimes put underground). A community loses a natural asset when this happens. Channelizing a natural waterway usually speeds up the flow, causing greater downstream flood peaks and higher drainage costs, and does nothing to enhance the environment. Natural streams within an urbanizing area require stabilization, not channelization.
- 6) **Channel Capacity:** Streams having “slow flow” characteristics, vegetated bottoms and sides, and wide water surfaces provide significant floodplain capacity. This capacity is beneficial because it reduces downstream runoff peaks and provides an opportunity for groundwater

recharge. Wetland channels, wide natural streams, and adjacent floodplains provide urban open space.

- 7) **Major Runoff Capacity:** Streams and their residual floodplains should be capable of carrying the 100-year storm runoff, which can be expected to have a one percent chance of occurring in any given year.
- 8) **Maintenance and Maintenance Access:** Urban streams require both scheduled and unscheduled maintenance activities such as the repair of structures, mowing and the removal of sediment, debris and trash. Assured long term maintenance is essential, and it must be addressed during planning and design.

2.2.7 Avoiding the Transfer of Problems

Planning and design of stormwater drainage systems should not be based on the premise that problems can be transferred from one location to another. Both intra-watershed and inter-watershed transfers should be avoided and appropriate assumptions should be made during site planning to avoid transfer of problems. Key principles include:

- 1) **Intra-Watershed Transfer:** Channel modifications that create unnecessary problems downstream should be avoided, both for the benefit of the public and to avoid damage to private downstream parties. Problems to avoid include land and channel erosion and downstream sediment deposition, increase of runoff peaks, and debris transport, among others.
- 2) **Inter-Watershed Transfer:** Diversion of storm runoff from one watershed to another introduces significant legal and social problems and should be avoided unless specific and prudent reasons justify and dictate such a transfer, no measurable damages occur to the natural receiving water or urban systems or to the public and all applicable laws are complied with.

2.2.8 Managing Runoff from Frequently Occurring Storms

Protecting and enhancing the water quality of streams is an important objective of drainage planning. Erosion control, maintaining stream stability, and reducing pollutant loading from stormwater runoff must be considered. Chapter 6: Water Quality, provides criteria for stormwater runoff BMPs that help to reduce runoff volumes for frequently occurring storm events and provide treatment of the water quality capture volume (WQCV), which is based on the 80th percentile runoff-producing event.

The first step in managing runoff from frequently occurring storms is implementing runoff reduction practices, also known as minimizing directly connected impervious area (MDCIA), which reduces the

amount and connectivity of impervious surfaces in a development. This can be accomplished through a variety of techniques such as functional grading, wide and shallow surface flow sections, disconnection of hydrologic flow paths, and the use of Low Impact Development systems. The extent to which MDCIA and runoff reduction can be implemented on a development site is dependent on the site conditions (e.g., soil type, groundwater depth, depth to bedrock) and development type (e.g., new development, redevelopment, ultra-urban and infill).

2.2.9 Watershed Approach to Stormwater Management

The City has initiated a “Watershed Approach” to stormwater management. This program includes three major watershed components and associated objectives:

- 1) **Land:** The objective of this component is pollution prevention, including public education, regulation, and enforcement. This is accomplished through implementation of the City’s Municipal Separate Storm Sewer System (MS4) permit, as described in the “Water Quantity and Quality Integration” Section of this Chapter.
- 2) **Tributaries:** The objectives of this component are stormwater treatment and pollutant load reduction and include the development of design criteria for “Control Measures”.
- 3) **Receiving Waters:** The objectives of this component are aimed at stream and habitat protection and restoration and include the creation of buffer zones on creeks and natural drainage ways.

The water quality protection regulations as specified in this Manual are primarily directed at the tributaries component of this approach. This includes BMPs for erosion control during construction and post-construction controls for development sites. These BMPs are intended to be located onsite; and therefore, address runoff from development sites or from any public improvements.

Any public or private improvement that has an impact on receiving waters must be constructed in accordance with the criteria specified in this Manual, the City’s Master Drainage Plans, City Code, the City Land Use Code and any other applicable State or federal regulations such as the United States Army Corps of Engineers (USACE) 404 permit requirements.

Runoff generated from any public or private improvement and directed into historic and natural drainage ways must be done in a manner that would promote the multi-functional use of these drainage ways, protect and restore their natural functions and enhance their aesthetic value.

Natural drainage ways, including creeks and streams, are considered important community assets that contribute to the aesthetic value and the livability of the urban environment. Their function extends beyond that of conveying floodwater, to their use as trails and open space corridors, for water quality

protection and enhancement, and to preserve natural vegetation and wildlife habitat to the greatest extent possible.

Public or private improvements located in or near receiving waters, must not adversely affect the natural character of the stream or water course. To that effect, the following provisions must be met:

- 1) Pollutant reduction and treatment facilities must be located upstream of streams and natural drainage ways.
- 2) Natural drainage ways must remain in as near a natural state as practicable.
- 3) Any proposed modification, including any erosion mitigating measures, must be designed and constructed in a manner that protects and enhances the natural character of receiving waters. Such modification must be addressed in the Drainage Report and clearly shown on the associated Drainage Plans.

2.3 Technical Criteria

Designing for storm drainage requires detailed examination of the specific requirements of the technical criteria presented in this Manual. The key components of the technical standards presented in this Manual include: determining runoff magnitude, detention basin design, water quality components of stormwater management, the use of streets for stormwater conveyance, inlets, piping and conveyance design, the use of Best Management Practices for permanent erosion control measures, and long-term maintenance of stormwater facilities.

2.3.1 Determining Runoff Magnitude

Runoff magnitude shall be determined by using the Rational Formula or the Stormwater Management Model (SWMM).

[Reference:](#) Refer to [Chapter 5: Hydrology Standards](#), for further discussion regarding runoff determination.

2.3.2 Detention Basins

Stormwater runoff can be temporarily detained in detention basins. Such detention, when properly designed, constructed, and maintained with adequate assurances for the long-term, can reduce the peak flow drainage capacity required, thereby reducing the land area and expenditures required downstream.

Onsite detention is required for all new development, as well as when detention is deemed necessary to protect structures or downstream properties when 1000 square feet or more of imperviousness is created with said development. The required minimum detention volume, with minimum and maximum release rate(s) for the developed condition 100-year recurrence interval storm must be determined in accordance with the conditions and regulations established in the appropriate Master Drainage Plan(s) for that development and in accordance with the criteria set forth in this Manual.

All detention facilities constructed after August 5, 2015 must meet the requirements of “stormwater detention and infiltration facilities” under CRS §37-92-602(8) which was enacted through Senate Bill 15-212. Further discussion regarding the design and construction of detention facilities to meet the requirements of this statute is included in Chapter 5: Detention, of this Manual.

Development should also provide detention of storm runoff close to the points of rainfall occurrence to the extent practical. Opportunities for detention include onsite detention basins, parking lots, ball fields, property line swales, parks, road embankments, and borrow pits. Wherever reasonably acceptable from a social standpoint, parks should be used for short-term detention of storm runoff. Such use may help justify park and greenbelt acquisition and expenditures. This "Blue-Green" concept was introduced in the 1960's (Jones 1967) and remains an effective strategy in drainage planning.

[Reference:](#) Refer to Chapter 6: Detention Chapter, for further discussion on the requirements for detention.

2.3.3 Retention Ponds

Retention ponds hold a permanent pool of water and typically have very minimal or zero water release by gravity.

Retention ponds are generally not allowed in Fort Collins and typically require a legal right to store water in Colorado. Consultation with the State Engineer's Office is needed in such cases and special permission from the FCU would be required for any retention pond design or installation.

2.3.4 Municipal Separate Storm Sewer System (MS4) Permit

Pursuant to the federal Clean Water Act and the Colorado Water Quality Control Act, owners and operators of Municipal Separate Storm Sewer Systems (MS4s), such as the City, are required to obtain permit coverage for stormwater discharges from their MS4s to surface waters of the state. The City is authorized under Colorado Discharge Permit System (CDPS) General Permit COR090000, certification #COR090050.

All discharges authorized by the MS4 permit shall be in accordance with permit conditions, including pollutant restrictions, prohibitions, and reduction requirements. As the permit holder, the City is required to implement the following programs. Only Construction and Post-Construction Stormwater

Management requirements are covered in the subsequent text and Chapters of this Manual, which include various requirements for Developers.

- 1) Public Education and Outreach
- 2) Illicit Discharge Detection and Elimination
- 3) Construction Sites Stormwater Management
- 4) Post Construction Stormwater Management in New Development and Redevelopment
- 5) Pollution Prevention/Good Housekeeping for Municipal Operations

Applicable Development Sites: must prevent or reduce pollutant discharge to the MS4. Although “applicable development sites”, “applicable construction activity”, “new development” and “redevelopment” sites are specifically defined in the MS4 permit, the City may apply more stringent requirements, as set forth in this Manual. In addition, the MS4 permit outlines specific sites that may be excluded from the requirements of an applicable development site. City policy is that only those exclusions specifically listed in the MS4 permit may be allowed. Exceptions or variances to the requirements of the MS4 permit cannot and will not be granted.

Regulatory Mechanism: Article II, Section 7 of the City Charter, Article 3 of the Land Use Code and Chapter 26 of the City Code provide the City legal authority to implement and enforce the requirements of this Manual.

Control Measures: The design requirements set forth in Chapter 7: Water Quality and Chapter 4: Construction Control Measures address the reduction of pollutant discharges to the MS4 through temporary erosion control measures and permanent BMPs.

Site Plans: Project designs are reviewed through the City’s development review process. The drainage report and construction plans submittal requirements set forth in Chapter 2: Development Submittal Requirements adhere to the Site Plan requirements established in the MS4 permit.

Construction Inspection and Acceptance: Acceptance procedures are outlined in Chapter 3: Post-Construction Requirements. Inspection is implemented through the City’s MS4 construction and post-construction and enforcement program.

Long-term Operation and Maintenance and Post Acceptance Oversight and Enforcement Response: Requirements are implemented through the City’s MS4 post-construction inspection and enforcement program.

[Reference: City of Fort Collins MS4 Permit information](#)

2.3.5 Water Quality

Water quality treatment of stormwater runoff is required for parcels that are developing, redeveloping or sites that are required to meet Land Use Code requirements if the development is adding or modifying 1000 square feet of imperviousness or more, or if the development involves land disturbing activities that disturb one (1) acre or more with no added impervious area. Water quality treatment facilities must include a combination of “standard” water quality treatment provisions (e.g. WQCV in extended detention basins) and Low Impact Development (LID) treatment provisions. FCU institutes minimum design requirements for both “standard” water quality and “LID” systems but requires, however, that 100% of development sites are captured for treatment, per the MS4 requirements.

There are regional water quality detention facilities available for use for certain basins in the City. Water quality requirements for a development may be deemed met where FCU determines that an applicant has made a sufficient showing that the existing regional water quality detention facilities are sized with the capacity to accommodate flows from a fully developed basin (including the development site in question) and are publicly owned and maintained, provided that any requirements for cost sharing or reimbursement to the City have been met. The Design Engineer will need to coordinate with FCU staff to determine if the development parcel in question drains to a regional facility.

[Reference:](#) [Water quality control treatment thresholds can be achieved through the use of an array of methods and devices as described in Chapter 7: Water Quality.](#)

2.3.6 Four Step Process to Minimize Adverse Impacts of Urbanization

UDFCD has long recommended a Four Step Process for receiving water protection that focuses on 1) reducing runoff volumes, 2) treating the water quality capture volume (WQCV), 3) stabilizing streams and 4) implementing long-term source controls. The Four Step Process pertains to management of smaller, frequently occurring events. Implementation of these four steps helps to achieve stormwater permit (e.g. MS4 permit) requirements. Added benefits of implementing the complete process can include improved site aesthetics through functional landscaping features that also provide water quality benefits.

Management of runoff from frequently occurring storm events shall include consideration of the following four steps.

- 1) **Employing runoff reduction practices:** This is done to reduce runoff peaks, volumes and pollutant loads from urbanizing areas, and by implementing LID strategies including MDCIA.
- 2) **Implementing best management practices (BMPs) that provide a water quality capture volume with slow release and/or infiltration:** After runoff has been minimized, the remaining runoff should be treated through capture and slow release of the WQCV.

- 3) **Stabilizing streams:** During and following development, natural streams are often subject to bed and bank erosion due to increases in frequency, duration, rate and volume of runoff. Although steps 1 and 2 help to minimize these effects, some degree of stream stabilization is required, either directly or indirectly.
- 4) **Implementing site specific and other source control BMPs:** Site specific needs such as material storage or other site operations require consideration of targeted source control BMPs.

[Reference:](#) Refer to Chapter 7: Water Quality for more detailed information on the Four Step Process.

2.3.7 Low Impact Development

Low Impact Development (LID) is simply defined as an integrated, sustainable stormwater management program that requires a more distributed, landscaping-based stormwater runoff control that relies mainly on filtration and infiltration to treat and manage stormwater runoff.

LID systems are required to be included as a stormwater quality treatment provision for any developing site that is also required to meet current Land Use Code requirements and if the site development is adding or modifying 1000 square feet of imperviousness or more. LID systems provide a higher degree of stormwater quality treatment than that provided with standard water quality design. Implementation of LID systems requires one of the following two options:

- 1) 50% of the newly added or modified impervious area must be treated by LID techniques and 25% of new paved areas must be pervious; or
- 2) 75% of all newly added or modified impervious area must be treated by LID techniques

[Reference:](#) Refer to Chapter 7: Water Quality, and Appendix C: LID Implementation Manual for more detailed requirements for incorporating low impact development systems into site designs.

2.3.8 Use of Streets

Streets are a significant component of the urban drainage system, and use of streets for storm runoff should be made within reasonable limits, recognizing that the primary purpose of streets is for traffic. Reasonable limits of the use of streets for conveyance of stormwater should be governed by design criteria provided in this Manual.

The criteria in this Manual are consistent with the intent that streets should not be used as stormwater conveyance for initial storm runoff. Usability of the street during minor storms and reduction of street maintenance costs should be objectives of urban drainage design and that major storm runoff will be removed from public streets at frequent and regular intervals and routed into streams, as well as the recognition that runoff tends to follow streets and roadways; therefore, streets and roadways may be aligned to provide a specific runoff conveyance function.

Initial and major drainage planning should go hand-in-hand. When maximum allowable street encroachment will be exceeded, a storm drain system based on the initial storm should be planned. Development of a major drainage system that can also drain the initial runoff from the streets is encouraged; this enables the storm drain system to commence further downstream. Drainage design objectives for streets should include reducing street repair and maintenance costs, minimizing nuisance to the public, and minimizing frequent disruption of traffic flow.

Reference: [Incorporating the use of streets in the use of stormwater conveyance must comply with the design requirements set forth in Chapter 9: Streets, Inlets and Conveyance, and with the Larimer County Urban Area Street Standards \(LCUASS\).](#)

2.3.9 Open Channels

Developments in or near major runoff channels must be planned and designed to maintain channel stability. Developments in and near major runoff channels must adopt measures to ensure that excessive erosion does not occur under peak flood flow conditions.

Realignment of natural channels in urban areas is not encouraged and may only be permitted if the FCU approves a design that maintains stream stability and aesthetics, enhances or improves the ecological character of the natural channel and prevents failure and erosion under peak flow conditions.

Reference: [The design of open channels must comply with all the appropriate provisions set forth in Chapter 9: Streets, Inlets and Conveyance.](#)

2.3.10 Use of Irrigation Ditches and Reservoirs

Irrigation ditches and reservoirs should not be used as outfall points for initial or major drainage systems, unless such use is shown to be without unreasonable hazard, there are no other outfall options and the outfall does not exceed historic runoff (rate and volume) into the ditch or reservoir, as substantiated by thorough hydraulic engineering analysis, and written approval of the ditch or reservoir owner(s) is obtained. In addition, irrigation ditches and reservoirs cannot be relied on to mitigate upstream runoff.

Stormwater facilities and improvements must be designed to avoid discharge of runoff from urban areas into irrigation ditches and reservoirs, except as required by decreed water rights or where such discharge is in conformance with the approved Master Drainage Plan. Where either of these conditions are present, the Developer must submit to the Utilities Executive Director and the affected ditch or reservoir owner(s) or other affected parties documentation of the relevant water rights-related constraint or Master Drainage Plan condition.

The Utilities Executive Director may approve of this discharge into irrigation ditches and reservoirs only upon a determination that sufficient showing has been made that such a discharge is acceptable to the affected ditch or reservoir owner(s), will not result in harm or interfere with the operation of affected stormwater management plans or systems, and that the requirements for a modification have been met (i.e. it is required by decreed water rights or is in conformance with the approved Master Drainage Plan).

In addition, whenever irrigation ditches cross major drainage channels in developing areas, the responsible party must separate stormwater runoff flows from normal ditch flows.

Whenever development occurs where an irrigation ditch or reservoir or other facility is present, the responsible party must provide adequate easements or other interests for ditch and reservoir operations, maintenance and repair, as required by the owner(s) of the ditch or reservoir.

[Reference: Refer to Chapter 9: Streets, Inlets and Conveyance for requirements regarding the use of irrigation ditches and reservoirs.](#)

2.3.11 Erosion and Sediment Control

Erosion and sedimentation are natural processes, the intensity of which is increased by Construction Activities. Clearing and stripping of land can cause localized increased erosion rates with subsequent deposition of sediments and damage to adjacent downstream and leeward properties. Erosion can reduce or destroy the aesthetic and practical values of neighboring properties, streams, lakes, wetlands and rivers. The methods and means to disturbing these areas may also bring materials and degrade water quality that if not maintained and handled properly may result in more impactful pollution discharges to these downstream parties and cause irreversible impacts to receiving waters.

The City is committed to the enhancement and protection of existing development, storm water infrastructure, streams, lakes, wetlands and rivers that may be impacted by sediment and pollutant laden runoff resulting from Construction Activities.

Therefore, it is City policy to encourage maintenance of the natural balance between sediment or other such pollutant supply and transport. To accomplish this balance of pollutants associated with construction, the City promotes programmatic implementation of criteria and specifications used to train, educate, and promote knowledge transfer and continually raise awareness of the issues

associated with Construction Activities and the pollutant transport from those activities. Through education and training based on clear guidelines, the City seeks to change behaviors through the design and infield implementation of Control Measures to reduce the quantities of pollutant materials allowed to impact the stormwater infrastructure and thereby ultimately protecting and enhancing receiving waters from the effects of Construction Activities.

With respect to construction control measures, the City's goal is to encourage control of erosion by leaving land undisturbed as long as possible (through project phasing), and once disturbed, to encourage Erosion and Sediment Control Measures be implemented to reduce pollution discharges directly from the exposed land and indirectly from the activities to rework that land. Control Measures, frequently referred to as BMPs, must be implemented until the site has been fully constructed and all vegetation has been re-established.

The City has determined that planning for and creating materials for the use of these Control Measures and practices, involves taking a proactive stance that can reduce the ground erosion, sediment deposition, and pollutant transportation to an acceptable level. Projects (or phases of projects depending on size) shall be designed to adequately anticipate and reduce possible erosion, sedimentation, and pollution discharges associated with Construction Activities.

Reference: Erosion Control documentation must be prepared in accordance with the criteria set forth in Chapter 2: Development Submittal Requirements, and implemented for all development, both public and private as explained in Chapter 3: During and Post-Construction Requirements. Selection of Construction Control Measures can be found in Chapter 4: Construction Control Measures. Other tools and information to facilitate meeting the Erosion Control Criteria can be found in Appendix D: Construction Control Measures Guidance.

2.3.12 Maintenance

Proper design and construction of stormwater facilities is necessary to minimize future maintenance and operating costs and to avoid public nuisances, health hazards, and safety hazards. This is particularly important given the many detention facilities and extents of storm piping in urban areas.

Long-term maintenance provisions must be prescribed for detention and water quality facilities. Maintenance of detention facilities includes the removal of debris, excessive vegetation from the embankment, and sediment. Maintenance requirements for water quality facilities (BMPs) vary, depending on the BMP type. Without maintenance, detention, retention, and water quality facilities will become unsightly social liabilities and eventually become ineffective for their intended functions.

All drainage facilities must be designed to minimize the need for facility maintenance and must provide for ease of maintenance access to all storm drainage facilities in order to ensure the continuous operational function of the system.

Maintenance access for all stormwater control and treatment facilities must be adequate and must be clearly delineated on the Final Development Plans for any development. Maintenance responsibility must be clearly described on the Final Development Plans and in the Standard Operating Procedures (SOPs) that are part of the Development Agreement.

Stormwater control and treatment facilities must be continually maintained to ensure their long term operational effectiveness. Maintenance of storm drainage facilities includes, but is not limited to, the regular performance of the following activities:

- 1) Mowing for weed control and removal of dead grasses; regularly scheduled during summer months.
- 2) Sediment and debris removal from channels, storm sewers and stormwater treatment facilities; scheduled periodically and after storm events.
- 3) Trash racks and street inlets must be cleared of debris; scheduled seasonally and after storm events.
- 4) Pipe inlets and outlets must be cleaned and cleared of vegetative overgrowth; scheduled regularly.
- 5) Channel bank erosion or damage to drop structures must be repaired to avoid reduced conveyance and treatment capability, unsightliness, and ultimate failure.

Pursuant to City Code Section 26-547, persons responsible for any private storm drainage facility, whether by law or as a condition of development approval or Development Agreement, shall maintain and operate said facility in accordance with maintenance best management practices.

Specific maintenance procedures are outlined in SOPs that are included as part of the Development Agreement for a project. Should the owner or responsible party fail to adequately maintain said facilities, the City has the right to enter said property for the purpose of maintenance as described in City Code Section 26-22. All such maintenance costs will be assessed to the property owner in accordance with City Code Section 26-28.

2.3.13 Floodplain Regulations

Floodplain rules and regulations for all development activities in and adjacent to the City-regulated floodplains as well as requirements for development within FEMA regulated floodplains is beyond the scope of this Manual.

[Reference:](#) Floodplain regulations can be found in Chapter 10 of the City Code.

Chapter 2: Development Submittal Requirements

Contents

- 1.0 Overview 1
- 2.0 Conceptual Reviews (CR) and Preliminary Design Reviews (PDR) 2
- 3.0 Overall Development Plan (ODP) Submittal Requirements..... 3
 - 3.1 ODP Drainage Report Requirements 3
 - 3.2 ODP Drainage Map Requirements..... 4
- 4.0 Project Development Plan (PDP) and Final Plan (FP) Submittal Requirements..... 5
 - 4.1 PDP / FP Drainage Report General Topics 6
 - 4.2 PDP / FP Drainage Report Requirements..... 6
 - 4.3 PDP / FP Drawing Requirements..... 9
 - 4.4 Other Supporting Documentation 12
 - 4.5 Development Agreements..... 12
 - 4.6 FP Approval Process..... 13
- 5.0 Other Application Types Process Requirements..... 14
 - 5.1 Drainage Memorandums 14
- 6.0 Erosion Control Material Requirements 15
 - 6.1 Standards and Submittal Requirements 15
 - 6.1.1 Projects That Do Not Need Erosion Control Materials 19
 - 6.1.2 Request for Project Clarification Regarding the Applicability of Requirements..... 19
 - 6.1.3 Elements of an Erosion Control Plan..... 20
 - 6.1.4 Elements of an Erosion Control Report..... 27
 - 6.1.5 Erosion Control Escrow 34
 - 6.2 Submittals, Review and Acceptance of Construction Drawings 38
 - 6.2.1 Submittal Check lists of Erosion Control Requirements 38
 - 6.3 State and Federal Requirements and Programs Applied Locally 39
 - 6.3.1 State Permit: Stormwater Discharges Associated with Construction Activities..... 39
 - 6.3.2 Qualifying Local Program 39
 - 6.3.3 Rainfall Erosivity Waivers..... 40
 - 6.3.4 Oil and Gas Operations & Exploration 40

Chapter 2: Development Submittal Requirements

- 6.3.5 Chemical Removal of Sediment Laden Water from Construction 40
- 6.4 Erosion Control in the Development Review Process Map..... 41
- 7.0 Floodplain Modeling Reports..... 45
- 8.0 Variance Request Process 45
 - 8.1 Advisory Consideration of Draft Variance Requests 45
 - 8.2 Variance Request Requirements..... 45
 - 8.3 Review of Variance Requests 46

1.0 Overview

All land development proposals in Fort Collins are administered through the City's development review process in accordance with the procedures outlined in the Land Use Code. Fort Collins Utilities (FCU) requires stormwater drainage design and analysis, erosion control materials, and if applicable, floodplain reviews, to be included as a part of the development review procedures. This Chapter outlines the submittal requirements to FCU for drainage and erosion control for each step of the development review process. Development proposals are required to fully address these submittal requirements prior to the issuance of building or construction permits. This Chapter does not include floodplain regulation or review process information.

[Reference:](#) [Information on floodplain regulations and the floodplain review process can be found in Chapter 10 of the City Code.](#)

Under the Land Use Code, the most common types of land development applications include **Overall Development Plans (ODP's)**, **Project Development Plans (PDP's)**, **Final Plans (FP's)**, **Basic Development Reviews (BDR's)** and **Building Permit Applications**. These and all other development applications are subject to storm drainage and erosion control design requirements if the development increases or modifies the impervious area by 350 square feet or more, or if the development disturbs more than 10,000 square feet.

In general, steps in the development review process occur sequentially according to the figure shown below. Detailed submittal information for each step is provided in the following sections of this Chapter. Specific development process requirements for other City departments will need to be verified with the appropriate department or assigned planner for the project and in accordance with the development review process and Land Use Code.

2.0 Conceptual Reviews (CR) and Preliminary Design Reviews (PDR)

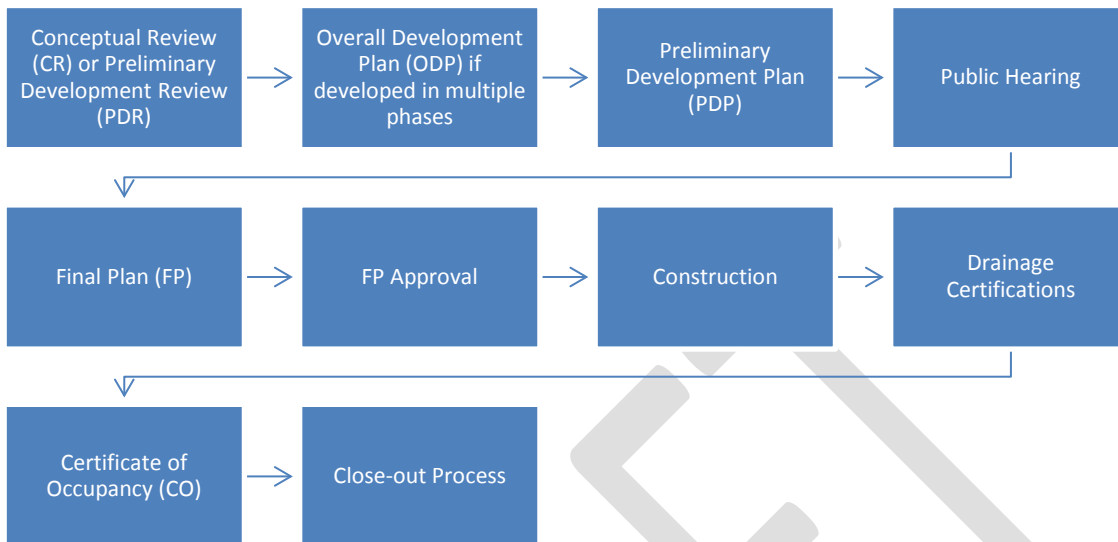
Figure 1.0 Development Review ProcessReferences:

- [City of Fort Collins Land Use Code](#)
- [Development Review Center process, applications and submittal requirements.](#)

2.0 Conceptual Reviews (CR) and Preliminary Design Reviews (PDR)

Conceptual Review (CR) and Preliminary Design Review (PDR), as defined in the Land Use Code, provides the applicant an opportunity to meet with representatives from several departments within the City, including FCU, to discuss requirements, standards, and procedures that apply to a development proposal. During the CR or PDR process, important issues or concerns can be identified prior to a formal application being submitted to the City.

In addition to the required submittal documentation, the applicant may opt to submit the following stormwater drainage information if available: existing and/or proposed stormwater drainage courses and facilities and any other natural features significant to drainage, within or near the proposed development. This additional information is helpful in aiding FCU review of the application, but not required.

3.0 Overall Development Plan (ODP) Submittal Requirements

An Overall Development Plan (ODP), as defined in the Land Use Code, is to establish general planning and development control parameters for projects that will be developed in phases with multiple submittals while allowing sufficient flexibility to permit detailed planning in subsequent submittals.

The required stormwater drainage information presented in an ODP submittal does not normally entail a detailed drainage and erosion control analysis of the project but does require a general presentation of the project’s features and effects on drainage and land disturbance. An ODP Drainage Report and an ODP Drainage Map are required to be submitted as a part of the overall ODP submittal package.

3.1 ODP Drainage Report Requirements

The ODP Drainage Report must show feasibility and design parameters for the proposed development. It must also show general compliance with the appropriate Drainage Basin Master Plan. Specific ODP Drainage Report requirements are outlined in the **Table 3.1-1** below.

Table 3.1-1: ODP Drainage Report Requirements

<p>General Location & Existing Site Information</p>	<ul style="list-style-type: none"> • Section, Township, Range • Vicinity Map • Roadways within and adjacent to the site • Master drainage basin where site is located (See the Master Drainage Basin map in Chapter 1) • Any existing stormwater drainage facilities and drainage patterns • Any existing irrigation, ditches, reservoirs, or other facilities in the area • Existing ground cover and/or type of vegetation
<p>Master Drainage Basin Description</p>	<ul style="list-style-type: none"> • Reference and discussion regarding the master drainage basin in which the project site is located • Any master planning improvements on or adjacent to the site • General basin characteristics • Existing and planned land uses within the basin • Irrigation ditches, reservoirs, or other facilities that influence or are influenced by the local drainage
<p>Floodplain Information</p>	<ul style="list-style-type: none"> • Existing floodplain and floodway information • Other planning studies such as flood hazard delineation reports and flood insurance rate maps
<p>Project Description</p>	<ul style="list-style-type: none"> • Proposed land uses and/or project summary • Site acreage • Names of surrounding developments

3.0 Overall Development Plan (ODP) Submittal Requirements

Proposed Drainage Facilities	<ul style="list-style-type: none"> Proposed drainage patterns Location and approximate size of detention basin and outlet design Area to be serviced by the drainage improvements Low Impact Development (LID) system considerations or options Potential impacts on the project site from offsite basins under existing and fully developed basin conditions pursuant to zoning and land use plans adopted by the City Conveyance of minor and major stormwater drainage to an existing stormwater conveyance system Specific details may be required, depending on the drainage complexities of the project site. These may include drainage issues at specific design points, maintenance and access aspects of the drainage facilities, and/or impacts of concentrating flows on downstream properties
References	<ul style="list-style-type: none"> Referenced criteria, master plans, technical information
Appendices	<ul style="list-style-type: none"> Project site drainage calculations based the ODP site plan Detention basin volume calculations based on the ODP site plan

3.2 ODP Drainage Map Requirements

The ODP Drainage Map must be included within the ODP plan set. Specific ODP Drainage Map requirements are outlined in **Table 3.2-1** below.

Table 3.2-1: ODP Drainage Map Requirements

Existing Drainage Information	<ul style="list-style-type: none"> Identify drainage flows entering and leaving the project site and general drainage patterns Indicate location of drainage from any offsite basins to the defined major drainage ways and all other existing drainage facilities Major drainage basin boundaries and sub-boundaries Any offsite drainage feature influencing development
Existing Watercourses	<ul style="list-style-type: none"> All watercourses, rivers, wetlands, creeks, and irrigation ditches or laterals located on or within 150 feet of the property
Imagery and Topography	<ul style="list-style-type: none"> Include an aerial photograph background image and existing topographic contours, if available
Floodplain Information	<ul style="list-style-type: none"> All 100-year floodplain and floodway boundaries, cross sections, and base flood elevation lines must be shown. FEMA-regulated floodplains - Base Flood Elevations must be reported in NAVD 1988 and NGVD 1929 (unadjusted) vertical datum City-regulated floodplains - Base Flood Elevations must be reported in NAVD 1988

4.0 Project Development Plan (PDP) and Final Plan (FP) Submittal Requirements

Proposed Drainage Facilities	<ul style="list-style-type: none"> • Proposed drainage flow directions • Proposed contours, if available • Proposed drainage facilities (general locations) including detention basins, water quality and/or LID basins, storm sewers, streets, culverts, channels and swales
Legend	<ul style="list-style-type: none"> • Defining map symbology

A separate checklist for the ODP Drainage Report and the ODP Drainage Map are included in Appendix A. These checklists shall be referred to when preparing these ODP documents and a copy of the filled-out checklist shall be provided with the first submittal.

4.0 Project Development Plan (PDP) and Final Plan (FP) Submittal Requirements

A Project Development Plan (PDP) is required for most projects processed through the development review process in the City. The PDP is typically preceded by a Conceptual Review (CR) and possibly an Overall Development Plan (ODP) if the project is to be developed in several phases. The PDP is considered the “preliminary” set of plans and must be completed and approved by staff prior to public hearing. Public hearings will be either type I (with an administrative hearing officer) or type II (with the Planning and Zoning Board). The type of hearing is determined by the planning department.

If the development is approved at the public hearing, the project may move into the Final Plan (FP) phase. If a PDP is required through the development review process, the requirements are as explained below.

The following listed requirements are compulsory for the PDP submittal. However, if a PDP is not submitted prior to an FP, or if the submittal is a combined PDP/FP, the PDP submittal documentation and drawing requirements are still required to be included within the FP submittal package requirements.

Major Amendments will also follow the requirements of Sections 4.2 and 4.3 of this Chapter.

All engineering reports and plans must be prepared or supervised by a professional engineer registered in the State of Colorado. All final reports will be required to be sealed with the professional engineers’ stamp and signature and dated.

Variances to the requirements in this Manual may be requested. The process for submitting a variance request is outlined in Section 8.0 of this Chapter.

Reference: The “Stormwater Alternative Compliance / Variance Application” may be provided to the Design Engineer upon request to the Stormwater Department.

4.0 Project Development Plan (PDP) and Final Plan (FP) Submittal Requirements

4.1 PDP / FP Drainage Report General Topics

In general, PDP and FP Drainage Reports must adequately address these four main topics, in order to receive FCU’s recommendation for approval at Public Hearing:

- 1) The project site must have a gravity outfall for stormwater and adequate downstream conveyance for said outfall. (If a gravity outfall is not practical, then an explanation of adequate stormwater conveyance that meets the requirements of this Manual is required. Any variance to this requirement must be approved prior to the Public Hearing pursuant to the terms of this Manual.)
- 2) The project site is designed to accept and route offsite stormwater drainage, if it exists.
- 3) Quantity detention analysis is included, if necessary.
- 4) Water quality and LID provisions are included.

Please note that any references in the report to “standards” or “criteria” refer to those in effect on the date the Drainage Report is approved.

4.2 PDP / FP Drainage Report Requirements

The requirements provided in this section are not intended to convey a specific Drainage Report outline that must be followed, but rather are provided as a checklist of items that need to be presented in a sequence or format determined by the Design Engineer.

All items required at PDP will also need to be included in the FP submittals. Items below specified in the FP rows are only required at the time of Final Plans.

Table 4.2: PDP/FP Drainage Report Requirements

Cover Letter	PDP	<ul style="list-style-type: none"> • Include the name of the project, date, name of the engineer designing the site, and statement of compliance with this Manual*
	FP	<ul style="list-style-type: none"> • Upon approval of the Final Plans, two paper copies of the Drainage Report must be submitted to FCU • Both copies are required to be stamped and signed by a Colorado licensed Professional Engineer
General Location & Existing Site Information	PDP	<ul style="list-style-type: none"> • Vicinity map • Section, township, range • Roadways within and adjacent to the site • Names of surrounding developments

4.0 Project Development Plan (PDP) and Final Plan (FP) Submittal Requirements

		<ul style="list-style-type: none"> • Master drainage basin where site is located (See the Master Drainage Plan map in Chapter 1) • Any existing stormwater drainage facilities and drainage patterns • Any existing irrigation ditches, reservoirs, and other facilities in the area • Existing land uses • Existing ground cover and/or type of vegetation • Existing soils information that includes rainfall and wind erodibility problems, limiting characteristics, groundwater depths, suitability of the soils for development
Master Drainage Basin Description	PDP	<ul style="list-style-type: none"> • Reference and discussion regarding the master drainage basin in which the project site is located • Any master planning improvements on or adjacent to the site • General basin characteristics including historic drainage patterns • Existing and fully developed land uses within the basin that are pursuant to zoning the Land Use Code • Irrigation ditches, reservoirs, or other facilities that influence or are influenced by the local drainage
Floodplain Information	PDP	<ul style="list-style-type: none"> • Refer to Floodplain Review Checklist for Development Review Submittals
Project Description	PDP	<ul style="list-style-type: none"> • Proposed land uses and/or project summary • Site acreage
Proposed Drainage Facilities	PDP	<ul style="list-style-type: none"> • Discussion of the proposed drainage plan, specific details that may include drainage issues at specific design points; discuss relationship and impacts to neighboring or downstream properties • Conveyance of minor and major flows to the major drainage way, offsite drainage considerations or facilities, if needed • Detention basin and outlet design, including a summary table for each detention basin • Water Quality Capture Volume (WQCV) design • Low Impact Development (LID) design, including a summary table and LID exhibit (please do not provide this information in a separate letter or report) • Maintenance access to the drainage facilities • Easements and tracts for drainage purposes
Drainage Design Criteria	PDP	<ul style="list-style-type: none"> • Reference to any previous drainage studies for the project site or adjacent areas that limit or influence the drainage design <p>Four-Step Process</p> <ul style="list-style-type: none"> • Discussion on how the project developments will Minimize Directly Connected Impervious Area (MDCIA) and discussion on how compliance with the “Four Step Process” is being implemented.

4.0 Project Development Plan (PDP) and Final Plan (FP) Submittal Requirements

		<p>Hydrological Criteria</p> <ul style="list-style-type: none"> Identify rainfall data used, design storm recurrence levels (i.e. 2-year, 100-year) runoff calculation method, detention calculation method, discussion, and justification of other assumptions or calculation methods that are not referenced by the Manual
	FP	<p>Hydraulic Criteria</p> <ul style="list-style-type: none"> Identify the various methods or software utilized in hydraulic capacity calculations Hydraulic Calculations for items such as: street capacity, inlet capacity, pipe network models, swales, channels, emergency spillway, or others as necessary
Variance Requests	PDP	<ul style="list-style-type: none"> Include Variance Request Form, if any, and discussion and reasoning for alternative compliance request
Erosion Control	PDP	<ul style="list-style-type: none"> Statement of compliance with Erosion Control Criteria and all Erosion Control Materials will be provided with the Final Drainage Report – or – Provide a letter and proof showing that the project does not need Erosion Control Material. Refer to Section 6.1.2
	FP	<ul style="list-style-type: none"> Refer to Section 6.1.4 of this Chapter for Erosion Control Report requirements Refer to Section 6.1.5 of this Chapter for Erosion Control Escrow Calculation requirements – or – Provide a letter and proof showing that this project meets the exemption requirements. Refer to Section 6.1.2
Conclusion	PDP	<ul style="list-style-type: none"> Statement of Compliance with this Manual, Master Drainage Plans, Floodplain Regulations, and/or State and Federal Regulations Drainage Concept: Effectiveness of drainage design to control damage from storm runoff, Influence of proposed development on the Master Drainage Plan recommendation(s)
References	PDP	<ul style="list-style-type: none"> Referenced criteria, master plans, technical information
Appendices	PDP	<ul style="list-style-type: none"> Hydrologic calculations – historic (or existing) and developed imperviousness, runoff coefficients, time of concentration and runoff rates Detention basin - volume calculations SDI Data Sheet (release rates meet drain time criteria) SWMM Models Low Impact Development (LID) - LID calculations and LID exhibit that shows contributory areas of the site to each LID feature Floodplain map Soil survey information or geotechnical report

4.0 Project Development Plan (PDP) and Final Plan (FP) Submittal Requirements

		<ul style="list-style-type: none"> • Drainage map
	FP	<p>Hydraulic calculations for items such as:</p> <ul style="list-style-type: none"> • Street capacity • Inlet sizing • Storm pipe design • Erosion protection • Swales and channels • Outlet structure design • Spillway design • Other items, as necessary

*Compliance statement: “I hereby attest that this report for the [preliminary or final] drainage design for the [project name] was prepared by me or under my direct supervision, in accordance with the provisions of the Fort Collins Stormwater Criteria Manual. I understand that the City of Fort Collins does not and will not assume liability for drainage facilities designed by others.” Registered professional engineer must affix their seal with signature and date.

4.3 PDP / FP Drawing Requirements

Items below specified in the “FP” row are only required at the time of Final Plans. Otherwise, all items listed below are required to be included in the PDP, and also in the FP drawings. In general, all drawings shall include the name of the subdivision or project, date of preparation, drawing scale, symbol designating true north and should be submitted on ARCH D (24”x36”) size paper.

Table 4.3: PDP / FP Drawing Requirements

Cover Sheet	PDP	<ul style="list-style-type: none"> • Name of project and/or subdivision • Date of preparation • Vicinity map
Site Plan	PDP	<ul style="list-style-type: none"> • Refer to the Development Review Guide PDP Site Plan requirements
	FP	<ul style="list-style-type: none"> • Refer to the Development Review Guide FP Site Plan requirements
Erosion Control Plan	FP	<ul style="list-style-type: none"> • Refer to Section 6.1.3 of this Chapter for drawing requirements for the Erosion Control Plan
Overall Grading Plan	PDP	<ul style="list-style-type: none"> • Existing prominent features accurately located and depicted. Prominent features include: waterways, ponds, wetlands, major utilities, irrigation ditches, reservoirs and other facilities, vegetation lines and trees, any natural habitat buffer zones that will be designated on the site

4.0 Project Development Plan (PDP) and Final Plan (FP) Submittal Requirements

		<ul style="list-style-type: none"> Existing and proposed site plan information such as: building footprints, parking lots, sidewalks, and streets including street names Existing and proposed boundary lines of the subdivision or project, right-of-way lines of streets, lot lines and easements Existing and proposed contours at a maximum of 1-foot (1') intervals. The contours should extend at least 50 feet outside of all project boundaries to show the drainage relationship with adjacent areas. Proposed contours shown at half foot (0.50') intervals for flatter sites or flatter areas (at discretion of FCU staff and/or Design Engineer) Stormwater outfall identified and labeled on the plans Proposed flow arrows and slope labels Proposed spot elevations Locations of proposed storm sewers, culverts, inlets, manholes, cross-pans, and other storm drainage facilities Locations of existing utilities where drainage design may affect the existing utility All floodway and floodplain boundaries and base flood elevation lines shall be included and clearly labeled.
Detailed Grading Plan	FP	<ul style="list-style-type: none"> This plan should incorporate pertinent information from the Overall Grading Plan requirements and should also include individual lot grading details such as: finished floor (FF) and/or minimum opening (MO) elevations for buildings or residences, lot line swales, front and back lot grades, grade breaks, etc. For single-family residential projects, typical lot grading detail drawings should also be included.
Floodplain Plan (if applicable)	PDP	<ul style="list-style-type: none"> Refer to Floodplain Review Checklist Development Review Submittals
Stormwater Plan and Profiles	FP	<ul style="list-style-type: none"> Size, type and class of all portions of storm sewer with lengths measured from manhole centers Manhole type, diameter, longitudinal stationing and any special features Matchlines with longitudinal stationing and sheet numbers

4.0 Project Development Plan (PDP) and Final Plan (FP) Submittal Requirements

		<ul style="list-style-type: none"> • Phase lines (if necessary) • Existing ground profile and proposed ground profile • Manhole rim and inflow/outflow inverts • Include 100-year HGL’s in the profile (EGL’s may also be required at the discretion of FCU) • Include all wet utility crossings and dry utility crossings in the profile • Identify all storm sewer segments as “private” or “public”
Subdrain Plan (if applicable)	FP	<ul style="list-style-type: none"> • Horizontal and vertical information on the subdrain system
Drainage Map	PDP	<ul style="list-style-type: none"> • Legend to define map symbols • Identify drainage flows entering and leaving the project site and general drainage patterns. The map should show the path of all drainage from the upper end of any offsite basins to the defined major drainageways. • Existing topographic contours at 1-foot (1’) maximum intervals. In terrain where the slope exceeds 15%, the maximum interval is 10 feet. The contours shall extend 50 feet beyond the property lines or further, if necessary, to show the drainage relationship with the adjacent property • All watercourses, rivers, wetlands, creeks, irrigation ditches, reservoirs and other facilities located within 150 feet of the property • Major drainage boundaries and sub-boundaries • All other existing drainage facilities • Any offsite feature influencing development • Proposed drainage facilities including detention basins with linework indicating the 100-year water surface elevation, water quality and/or LID basins, storm sewers, streets, culverts, channels and swales • Detention basin information: required volume, provided volume, water quality surface elevation, 100-year water surface elevation, discharge rates • Basin summary table to include: basin ID, acreage, peak discharges for the design storms
Construction Details	FP	<ul style="list-style-type: none"> • Low Impact Development (LID) details such as: pervious pavers, bioretention basins, sand filters, etc.

4.0 Project Development Plan (PDP) and Final Plan (FP) Submittal Requirements

		<ul style="list-style-type: none"> Stormwater facility details such as: trenching and bedding for pipes, manholes, inlets, outlet structure details, emergency spillway, riprap, conveyance appurtenances, etc.
--	--	--

4.4 Other Supporting Documentation

Other documentation in support of the development application may be requested. These items do not necessarily need to be a part of the Drainage Report or drawings, but may be provided separately. These items include but are not limited to the following:

- PDP - Letters of intent to acquire all necessary offsite easements. (Refer to Chapter 6: Water Quality and Chapter 7: Grading, for drainage easement requirements.)
- FP – Final easements and/or agreements (signed)
- FP – Soils Report
- FP – Environmental reports (if applicable)

4.5 Development Agreements

A Development Agreement is a legal document between the City, the Developer and Owner of a property. The Development Agreement describes and defines many of the terms and code requirements that apply to all developments and those specific to the development. Information regarding legal entities and signatories is needed to prepare the Development Agreement for review.

The Engineering Development Review department is in charge of the Development Agreement process and coordinating with other departments that represent interest in the Development Agreement language and requirements, as well as serving as the liaison between the Developer or Owner and the other City departments involved in formulation of the Development Agreement.

The project-specific information included in the Development Agreement is based on the final, or nearly final, Utility Plans, Drainage Report and Erosion Control Materials for that project. Per the Land Use Code, final plans (Utility Plans) will not be approved until the Development Agreement has been fully executed.

FCU will require that a Development Agreement is in place if there are detention basins and/or water quality or LID systems at the project site.

In general, Development Agreement language will typically include the following topics:

- Phasing of the construction of stormwater improvements, if applicable
- Information for all onsite and offsite stormwater facilities

4.0 Project Development Plan (PDP) and Final Plan (FP) Submittal Requirements

- Drainage Certification completion requirements relative to the timing of building permit issuance and CO issuance.
- Irrigation ditch and reservoir information or permissions, as necessary
- Stated compliance with the applicable drainage master plan release rates and required drain times for detention basins and LID facilities
- Land grading information that may need to be specifically included for individual lots, swales, sensitive areas, fencing restrictions, minimum openings for lots along drainage ways or detention basins
- Maintenance requirements for all stormwater drainage and water quality facilities (public and private)
- A process to allow for grade changes after drainage certification has been submitted
- Soil amendment requirements
- Developer repay process and requirements, if applicable
- Floodway and floodplain requirements, if applicable
- Erosion Control Inspection and enforcement, as necessary
- Submittal of the Erosion Control Escrow, if applicable
- Phasing of the Erosion Control Escrow, if applicable
- Installation, Maintenance and Final Removal Requirements of Temporary Construction Control Measures, if applicable

FCU will include the required project information in the Development Agreement and will coordinate with the Design Engineer, Developer or Owner to gather any additional information as necessary.

4.6 FP Approval Process

The approval process, once the Utility Plans are at the final stage, is generally outlined below. The process is managed by the Engineering Development Review Division and as such, the Design Engineer will be required to coordinate with them for these final steps to construction.

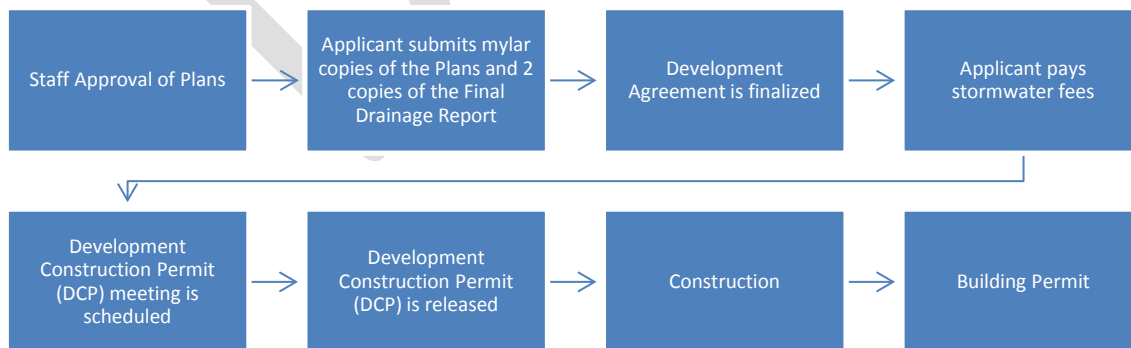

5.0 Other Application Types Process Requirements

Drainage Report and plans are required for most development projects. For certain types of land use applications, such as Minor Amendments, Change of Use and Basic Development Review (BDR) applications, specific requirements are determined by the extent of the development or redevelopment or change in impervious areas. The parameters are provided in **Table 5.0-1** below.

Table 5.0-1: Drainage Reports Submittal Requirements - Based on Impervious Area

Increase or Modification in Impervious Area	Submittal Requirements
< 350 square feet	<ul style="list-style-type: none"> • None
≥ 350 square feet and < 1000 square feet	<ul style="list-style-type: none"> • Simple Grading Plan* • Drainage Memorandum**
≥1000 square feet	<ul style="list-style-type: none"> • Detailed Grading Plan, based on accurate field survey (Refer to Section 4.3) • Drainage Report (Refer to Section 4.2) • Drainage Map (Refer to Section 4.3)

*Simple grading plan is basically a Site Plan with drainage arrows indicating drainage patterns. This does not need to be prepared by a P.E.

** Some submittals may not require a Drainage Memorandum to be included. This will require discussion and approval by FCU.

5.1 Drainage Memorandums

Drainage Memorandums are required to be submitted for sites that show an increase or modification of imperviousness between 350 and 1000 square feet. Drainage memos should generally include the following information:

Table 5.1-1: Drainage Memo Requirements

Cover Letter	<ul style="list-style-type: none"> • Date • Name of the Design Engineer designing the site • Statement of compliance with the FCSCM
Project Description	<ul style="list-style-type: none"> • Existing conditions • Proposed land uses and/or project summary; discuss relationship and impacts to neighboring or downstream properties • Description and quantification of impervious surface changes
Other	<ul style="list-style-type: none"> • Other specific items that may be identified by the Design Engineer or FCU

6.0 Erosion Control Material Requirements

FCU will review all Erosion Control Material submittals to ensure that they meet the Erosion Control Criteria as set forth in this Manual. Any acceptance by FCU of such materials does not relieve the Developer from the responsibility of ensuring that the Erosion Control Materials are in compliance with the requirements of this Manual, nor does such acceptance relieve the Developer the responsibility to fulfill the requirements of State and Federal law.

Any time the language between the criteria set forth in the Erosion Control Criteria, local codes (such as City Code and the Land Use Code), State Laws, and Federal Laws vary, the more restrictive language, criteria, standard, regulation, and/or law shall apply and be followed.

For projects in the formal Development Review Process, Erosion Control Materials may be submitted at any time prior to FP in the Development Review Process (Figure 1.0 of this Chapter) for review and comments. Erosion Control Materials shall be submitted no later than FP in the formal construction Development Review Process to meet the Erosion Control Criteria.

For projects, not in the formal Development Review Process, Erosion Control Materials may be submitted at any time prior to the final acceptance or approval of a project.

For all projects, it is recommended that materials be provided at 75-100% design. Early submission is encouraged as it can help ease certain aspects of the review and approval process.

6.1 Standards and Submittal Requirements

The City shall assume all projects need Erosion Control Materials unless determined otherwise, in accordance with Section 6.1.1 of this Chapter. Clarification of project requirements may be requested to confirm the appropriate exemption from the requirements as shown in Section 6.1.2 of this Chapter.

Erosion Control Materials shall consist of a combination of three elements noted below:

- Erosion Control Plan (Section 6.1.3 of this Chapter)
- Erosion Control Report (Section 6.1.4 of this Chapter)
- Erosion Control Escrow (Section 6.1.5 of this Chapter)

Erosion Control Materials shall be submitted, reviewed, and accepted by the City prior to the issuance of any of the following permits:

- Development Construction Permit

- Excavation Permit
- Stockpile Permit
- Building Permit (including demolition and Footing and Foundation (F&F) permits)

Erosion Control Materials shall be submitted and accepted by the City prior to commencing Construction Activities.

Which combination of documents will need to be provided as Erosion Control Materials shall be supplied based upon **Table 6.1-1** below.

DRAFT

6.0 Erosion Control Material Requirements

Table 6.1-1 Simplified Erosion Control Materials Submittal Table

Project Area of Disturbance and Other Factors	Follow §26-498 to prevent pollution	Meet Exemption Requirements (Section 6.1.1)	Request for Project Clarification (Section 6.1.2)	Erosion Control Plan -Map Set (Complete 2.1.3)		Erosion Control Report (Complete 6.1.4)	Erosion Control Escrow (Complete 6.1.5)	Phase Materials are required***	State Permit****
				w/ Sequence Chart (Section 6.1.3.2)	w/ Individual Sequence Sheet (Section 6.1.3.2)				
Emergency work <1 acre	X	X							
0 - <8,000 sq. ft.	X	X							
8,000 - 10,000 sq. ft.	X	~	X						
(>4):1 (Horizontal : Vertical)*	X	X							
4:1 to 3:1 (Horizontal : Vertical)*	X	~	X						
≥75 ft. away from Sensitive Areas. *	X	X							
50 - 75 ft. away from Sensitive Areas.*	X	~	X						
Demo work*	X		X						
Larger common plan or development or sale**	X			X		X	X		X
10,000 - 43,559 sq. ft.	X			X			X		
1 -3 acre(s)	X			X		X	X		X
3 - 5 acres	X				X	X	X		X
5+ Acres	X				X	X	X	X	X

* These are assumed to be less than 10,000 sq. ft. and not a part of a larger common plan or development or sale, otherwise follow the process for the most applicable area of disturbance, or the Larger common plan or development or sale line item.

** These projects are assumed to be less than 43,560 sq. ft.

***The phasing requirements are found in Sections 6.1.3, 6.1.4 and 6.1.5 of this Chapter)

****While the CDPS General Permit Stormwater Discharges Associated with Construction Activity is not a City issued permit, this requirement is identified in this table as a reminder to Developers.

∞ This requirement is not needed for municipal projects.

~ These projects may meet the Exemption Requirements in 6.1.1 however further information should be provided to verify that is the case.

DRAFT

6.1.1 Projects That Do Not Need Erosion Control Materials

Some projects do not require Erosion Control Materials. Such projects are:

- 1) Emergency work projects, where there is less than 43,560 ft² (1 acre) of Disturbed Area; or
- 2) Projects with Construction Activities that:
 - a. have less than 10,000 ft² of Disturbed Area;
 - b. have shallower slopes than (4H:1V);
 - c. have no Sensitive Areas and are further than 50 ft away from any Sensitive Area; and
 - d. do not require a CDPS General Permit Stormwater Discharges Associated with Construction Activity (typically as a result of a Larger Common Plan of Development or Sale).

These projects will not be required to submit Erosion Control Materials and are exempt from Erosion Control Requirements, as discussed in Section 2.1 of Chapter 4: Exemptions to the Scope of Erosion Control Requirements.

City staff may make a determination, on its own initiative or in response to a request from a Developer, that a project does not require Erosion Control Materials by meeting one of the two standards noted above. City staff will typically make such determinations without the need for additional information as discussed in the following subsection when it is self-evident that one of the above standards is met.

Note that any requests related to building permits for demolition must not be under any concurrent City review. If under a concurrent City review, the demolition work would be considered part of the larger project's Construction Activities, at which point the project cannot start until approved Erosion Control Materials have been accepted and Erosion Control Escrow has been received.

6.1.2 Request for Project Clarification Regarding the Applicability of Requirements

When it is not self-evident that Erosion Control Materials are not required as discussed in the previous section, additional information around the Project will need to be produced in writing to prove that the project does or does not require Erosion Control Materials.

The clarification to the City shall include such information as, but not limited to; project location, project name, applicable City permit numbers (if known), contact info, and a simple map as proof.

Proof given to the City shall be a simple map or plan showing:

- 1) Calculated Areas of Disturbance;
- 2) Steepest slope arrow; and
- 3) Shortest distance line from the Disturbed Area to a Sensitive Area (if within 75ft)

For questions about how to meet these criteria, please see Section 2.0 of Appendix D regarding examples of how this information may be presented.

This information will be used to determine whether Erosion Control Materials are or are not required. If Erosion Control Materials are not required, then FCU staff can remove all holds in review or permitting that are associated with a project. If Erosion Control Materials are required, use Table 6.1-1 of this Chapter to select the appropriate review materials.

6.1.3 Elements of an Erosion Control Plan

Erosion Control Plans shall be required of all applicable projects in accordance with this Manual, as summarized in Section 6.1, Table 6.1-1 of this Chapter. All areas of exposed soil will require to select Control Measures to prevent the potential pollution based on factors including the duration of exposure, soil erosivity, slope steepness, length, and other applicable factors. The plan should also identify the planned location of temporary construction roads, vehicle tracking controls, portable toilets, waste disposal areas, and material storage areas, concrete washouts, and temporary and or permanent seeding applications, etc. Control measures incorporated onto the Erosion Control Plan should be vetted against a Control Measures check list found at www.fcgov.com/erosion by the Developer.

Erosion Control Plans shall be found in the construction plans set prepared by or supervised by and stamped by a P.E. licensed in Colorado.

[Reference: All Erosion Control Plans shall be developed in accordance with requirements for "Utility Plans" found in Appendix E-4-FC in the Larimer County Urban Area Street Standards.](#)

Erosion Control Plans shall have erosion control information located in one of the following four locations within the plan set; the title page, the drawing / map sheet(s), the notes page(s), and the detail sheet(s). Erosion Control Plan sheets may be combined or spread out as needed or merged into other plan sheets (ex. grading or storm drainage) so long as all the required erosion control information can be clearly shown, and the combined plan is clear and that all the erosion control elements can be readily seen and/or deciphered.

Upon acceptance of the final plans (FP Approval in Figure 1.0 of this Chapter), a Mylar plan set and signing process is usually required for the Development Agreement (Section 4.5 of this chapter).

Required elements of an Erosion Control Plan (in addition to the requirements above) shall be:

- Chart or table of calculations (Section 6.1.3.1 of this Chapter)
- Project sequencing (Section 6.1.3.2 of this Chapter)
- General map characteristics (Section 6.1.3.3 of this Chapter)
- Erosion and control notes (Section 6.1.3.4 of this Chapter)
- Details (Section 6.1.3.5 of this Chapter)
- Phasing and large projects (if applicable) (Section 6.1.3.6 of this Chapter)

6.1.3.1 Chart or Table of Calculations

A chart or table shall include the following calculations and project specific details:

- Total Area of Disturbance for the project (in square feet or acres)
- Total “onsite” Area of Disturbance (in square feet or acres) within the property boundary
- Total “offsite” Area of Disturbance (in square feet or acres) beyond the property boundary
- Total storage/staging areas not incorporated into the onsite and offsite calculations (in square feet or acres)
- Total area of new or improved haul roads (offsite)
- Heavy construction vehicle traffic areas offsite (haul roads and heavy vehicle crossings as a result of Construction Activities)
- Approximate percent of the project that will be disturbed at any one time
- Estimated pre-existing percent vegetative density or percent vegetative cover (plant density or how thick the grass is) before the project was disturbed
- Existing soil type
- Depth to groundwater (in feet) (data shall be determined from data taken during high groundwater months to determine if dewatering activities are anticipated)

6.0 Erosion Control Material Requirements

- Number of phases associated with a project
- Total volume of material imported to (+), or exported from (-), the project (in cubic yards)
- Total area of offsite stockpiling of fill from the project or borrow from stripping the offsite area (in square feet or acres)
- Steepest slope (in a ratio of Horizontal to Vertical, H:V)
- Distance from a riparian area or sensitive area (in feet, if larger than 75 feet mark the field N/A)

An example Calculations Chart can be found in 3.0 of Appendix D.

6.1.3.2 Project Sequencing

Project sequencing has to do with a specific project area progressing from start to finish over time (chronologically i.e. grading, utilities installation, vertical building, landscaping etc.). As projects dynamically change over time the selection of Control Measures to prevent the potential of pollutant discharge on the project will change as well. Sequencing plans are an attempt to anticipate those changes on a project before a conflict or confusion in the plan will arise.

Sequencing differs from phasing a project. Phasing is dividing a project into large areas (geographically) that will be worked on at different times. On large projects (5 acres or greater) it is required that both phasing and sequencing are shown in the plans and report.

Note that the CDPS General Permit Stormwater Discharges Associated with Construction Activity does not differentiate between sequencing and phasing of construction Control Measures and only refers to them in the same context as “Phased BMP Implementation”.

Project sequencing shall come in one of two forms: either a sequence chart or sequence sheets. Both sequence charts and sequence sheets should include all of the following sequences of construction that are applicable to the size and scope of the project, which may be grouped together, as appropriate:

- Mobilization
- Demolition
- Grading
- Import or export of materials
- Utilities installation

- Flat work installation
- Vertical installation
- Landscape
- Demobilization
- Final stabilization

Sequence Chart

On non-exempt projects less than three acres for which Erosion Control Materials are required, a sequence chart is required to be included on the map sheet that outlines all of the Control Measures that are anticipated to be used during all of the various sequences of construction. The applicable Control Measure should be identified (checked, marked, highlighted, etc.) for each of the applicable sequences of construction in which that Control Measure will be used and implemented.

Section 4.0 of Appendix D includes sample sequence charts for reference.

Sequence Sheets

Projects greater than or equal to 3 acres will require a separate map sheet for each the major sequences during construction. Some sequences can be combined with others on the same sheet. For example Mobilization and Demo can be incorporated into an initial sheet. The sequence sheets shall have a minimum of 3 separate sequences of construction. Each sheet shall show the mapped location of each Control Measure and where they are to be used during that particular sequence of construction. The title page shall have the sequences sheets labeled in the table of content.

Section 4.1 of Appendix D includes an example of the sequence sheets in the title page as well as the erosion control sheets for reference.

6.1.3.3 General Map Characteristics

Key map characteristics shall include:

Characteristic	Description
Legend	- Every symbol included on the map - All symbols not to scale should be labeled as “Not to Scale”
Flow Arrows	- Indicate the direction of flow - For slopes steeper than 3:1 -For curb and gutter locations and areas with flow concentration - For flows onto the project (rates for 2- and 100-year storms)
Property Lines and Lot Lines	- Include on legend

6.0 Erosion Control Material Requirements

	<ul style="list-style-type: none"> - Include Owner information
Limits of Construction and Limits of Disturbance	<ul style="list-style-type: none"> - All areas that will be disturbed as part of project with: <ol style="list-style-type: none"> 1) distinctive boundary line that is labeled; 2) boundary line thickness and type that is dark/bold; or 3) lightly shaded/hatched area. - All areas of clearing and grading, including stages of any cut-and-fill operations.
Water Features	<ul style="list-style-type: none"> - including but not limited to: existing drainage, wetland, natural habitat buffer zones, streams, springs, stream corridors, creeks, lakes, or other surface water features - If temporary channel diversions and crossings are designed, the routes, sizing and lining should be included
Stormwater Drainage Features	<ul style="list-style-type: none"> - Including but not limited to; detention basins, LID facilities, water quality structures, inlets, pipes, culverts, storm sewers, drainage swale, concrete pans, aprons, paved areas, retaining walls, cribbing, irrigation ditches, reservoirs and other facilities, and other permanent features or outfalls - Permanent erosion control features - Drainage basins - Topographic contours existing and proposed and label and bold at the 100-year storm event water surface elevation - Permanent drainage features, such as channels, storm sewers, roadside swales, and stormwater quality controls such as ponds, wetlands, grassed-lined swales, buffer strips and areas of porous pavement
Transportation and Building Features	<ul style="list-style-type: none"> - Including but not limited to; streets (named and labeled), paths, ramps, medians, and sidewalks. - Location of all buildings and roads
Utility Tie-in Locations Offsite	<ul style="list-style-type: none"> - Including, but not limited to storm sewer, water and sanitary sewer. Electric, gas and telecommunications to be included when known.
Offsite Material Import or Export Storage and Haul Roads	<ul style="list-style-type: none"> - Borrow or stockpiling material from vacant spaces (excluding landscapers or building materials supply yards) within Fort Collins, including applicable construction Control Measures - Topsoil stockpile locations, including applicable construction Control Measures - All offsite stockpile storage locations shall have a label attached to the location on the sheet as follows: "Developer is required to pull a stockpile permit prior to using this area to store material".

Construction Control Measures	- All applicable Control Measures used to prevent the potential pollutant discharge from the project (including, temporary, permanent, structural, and non-structural)
-------------------------------	--

6.1.3.4 Erosion Control Notes

The “Standard Erosion Control Notes” shall be included in each Erosion Control Plan. The “Standard Erosion Control Notes” can be found in Appendix F. To ensure a consistent application of the standards on any project, these notes shall not be amended. It is recognized that standard notes may not address every erosion control issue at every project. As such, designers may add project specific terms and notes to the standard notes. These are to be included in a separate section and specifically labeled “Project Specific Erosion Control Notes.”

A copy of the Standard Notes is available on the City’s erosion control webpage www.fcgov.com/erosion as well as in Appendix F.

6.1.3.5 Details

A Control Measure detail shall be provided for each unique type of Control Measures that is shown on the sheet(s).

Standard Control Measure details accepted by FCU are ones that do not require further documentation; they can be found in Appendix E.

Any non-standard Control Measure, or alternative Control Measure, shall submit for a variance in accordance with Section 8.0 of this Chapter. Refer to Section 5.1 of Chapter 4: Documenting Alternative Methods of Control for further direction.

Any proprietary control, measure shall submit for acceptance in accordance with the guidance given in Section 4.5 of Chapter 4: Proprietary Control Measures.

6.1.3.6 Phasing and Large Projects

Projects over 5 acres shall employ phasing for all Erosion Control Plans to leave land undisturbed for as long as possible. Erosion Control Plans including phasing shall clearly delineate various areas or zones of a project. Plans can be combined onto one sheet or can be shown as a project progression. Section 4.2 of Appendix D includes examples of plans that include phasing.

Maps for projects including phasing must be scaled so construction Control Measures are visible and may require multiple maps, such as an “Index Map Sheet” or “Key Map”. Section 4.2 of Appendix D includes examples of index maps that include phasing.

DRAFT

6.1.4 Elements of an Erosion Control Report

An Erosion Control Report shall be required of all projects that are either greater than or equal to 43,560 ft² (1 acre), or part of a larger common plan of development or sale, in accordance with Table 6.1-1.

The Erosion Control Report shall be prepared by, or supervised by, and ultimately stamped by a P.E. licensed in Colorado.

The Erosion Control Report shall be typed and preferably submitted in a digital Adobe PDF format to simplify the review of materials.

Key required elements of an Erosion Control Report shall contain the following;

- Project title page, cover letter, notification of responsibility (Section 6.1.4.1 of this Chapter)
- Table of contents (Section 6.1.4.2 of this Chapter)
- Project description (Section 6.1.4.3 of this Chapter)
- Potential pollutant sources (Section 6.1.4.4 of this Chapter)
- Control measures (Section 6.1.4.5 of this Chapter)
- Installation and removal sequence of Control Measures (Section 6.1.4.6 of this Chapter)
- Project phasing (if applicable) (Section 6.1.4.7 of this Chapter)
- Maintenance and inspection requirements (Section 6.1.4.8 of this Chapter)
- Final vegetation and stabilization (Section 6.1.4.9 of this Chapter)
- Appendix (Section 6.1.4.10 of this Chapter)

6.1.4.1 Project Title Page, Cover Letter, Notification of Responsibility

Within the project title page, cover letter, and notifications sheets the following information shall be included:

- Name of project
- Date submitted

- Contact info (name, address, phone, email) for the following:
 - Owner
 - Developer
 - Contractor
 - Design Engineer
 - Erosion Control Administrator (SWMP Administrator)

The final copy of the document shall be signed, dated, stamped and turned in before Construction Activities can begin on the project. The final copy can be scanned and emailed to erosion@fcgov.com.

6.1.4.2 Table of Contents

The Erosion Control Report will require a Table of Contents. Refer to Section 5.0 of Appendix D for an example of an Erosion Control Report.

6.1.4.3 Project Description and Nature of Construction

The project description shall describe the current project characteristics and the final project use when the project is complete including the information below. An example of a project description can be found in Section 5.2 of Appendix D. When some sections are not applicable, include a statement to that effect.

The description and nature of construction shall include the following:

- Project Location (refer to Section 5.2.1 of Appendix D for an example)
 - Written description
 - Legal description
 - Parcel number
 - Address
 - GPS coordinates (latitude and longitude in decimal degrees, ex. 40.567873, -105.099345)

6.0 Erosion Control Material Requirements

- Existing Site Condition (refer to Section 5.2.2 of Appendix D for an example)
 - Physical soil properties
 - Hydraulic soil properties
 - Soil features
 - Pathway to the nearest receiving waters (From the outfall point(s) of the project and the flow path to Fossil Creek Reservoir or the Poudre River with directions and distances)
 - Existing vegetated areas to impervious areas (ratio of pervious to impervious area)
 - Estimated percent vegetative ground cover
 - Existing groundwater depth
- Identify non-stormwater discharge (springs, irrigation return flows)
- Existing steepness of slopes
- Existing structures
- Distances from riparian or sensitive areas
- Summary of ground contamination if known
- Rainfall and wind erodibility
- Any other existing relevant data (i.e. soil boring, lab tests, runoff coefficient of the soil, etc.)

Proposed Construction Activities:

- The section entitled Proposed Construction Activities shall include a description of the Construction Activities from the beginning of the project until the finalization of the project.

The Construction Activities shall also at a minimum include the following collected data:

- Total area of the project
- Total area of each phase (when applicable)

6.0 Erosion Control Material Requirements

- Describe where the size was limited to reduce soil exposure (where able)
- Total area of disturbance both on and off the project
- Total areas of staging and storage
- Total areas for hauling
- Total volume of imported and exported material

This section shall identify any possible environmental impacts on the surrounding properties as a result of these Construction Activities.

This section shall also identify what State and Federal permits and processes will need to be acquired as a part of this Construction Activity.

For further clarification on any of the proposed construction activities or possible environmental impacts, please see Section 5.2.3 of Appendix D.

6.1.4.4 Potential Pollutant Sources

The potential pollutant source section shall, at a minimum, identify whether the potential pollutant sources listed below will be present on the project.

Each potential pollutant source identified shall:

- describe the source
- evaluate its potential to contribute to runoff, and
- prescribe what Control Measures will be implemented

Shown below are the minimum potential pollutant sources that are to be evaluated on every project. For further information, refer to Sections 5.3.1-16 of Appendix D for a thorough discussion of each potential pollutant source as well as an example showing how to describe, evaluate and prescribe Control Measures for each potential pollutant source. When some sections are not applicable, include a statement to that effect.

1. All disturbed and stored soils
2. Vehicle tracking of sediments

6.0 Erosion Control Material Requirements

3. Management of contaminated soils
4. Loading and unloading operations
5. Outdoor storage of construction materials, building materials, fertilizers, and chemicals
6. Bulk storage of materials
7. Vehicle and equipment maintenance and fueling
8. Significant dust or particulate generating processes. It is important to reference the [Fugitive Dust Control Ordinance No. 044, 2016, §12-150 - §12-160](#) and the projects requirements to be in compliance with that ordinance.
9. Routine maintenance activities involving fertilizers, pesticides, detergents, fuels, solvents, and oils
10. On-site waste management practices
11. Concrete truck/equipment washing, including the concrete truck chute and associated fixtures and equipment
12. Dedicated asphalt and concrete batch plants
13. Non-industrial waste sources such as worker trash and portable toilets
14. Saw Cutting and Grinding
15. Other non-stormwater discharges including construction dewatering not covered under the Construction Dewatering Discharges general permit and wash water that may potentially contribute pollutants to the MS4
16. Other areas or operations where spills can occur.

6.1.4.5 Construction Control Measures

This section shall identify all the anticipated Control Measures associated with the project. Each Control Measure should have a description of the Control Measure and its implementation or shall reference the detail sheet (typically the details page) and/or the Erosion Control Report (typically as an appendix). The Control Measures mentioned here should be the ones described in Section 6.1.4.4 of this Chapter to treat the various potential pollutant sources.

6.0 Erosion Control Material Requirements

All the map-able Control Measures (i.e. many of the site and materials management controls) shall be called out in the Erosion Control Report and shall match those on the Erosion Control Plan.

All erosion Control Measures shown in the plans shall also be included in the report.

For an example, refer to Section 5.4 of Appendix D.

6.1.4.6 Installation and Removal Sequence of Control Measures

Detailed sequence schedule of the installation and removal of all the anticipated Control Measures shall be submitted as part of the Erosion Control Report.

The requirements of Section 6.1.4.5 and Section 6.1.4.6 of this Chapter may be combined. For an example of installation alone or combined, refer to Section 4.1 of Appendix D.

6.1.4.7 Project Phasing

If the project requires phasing as shown in Table 6.1-1 then an additional section shall be added to the Erosion Control Report and shall be titled project phasing. The project phasing section shall include a paragraph describing how the project will change and be broken into phases.

An estimated schedule for when each phase will begin and stabilized shall be discussed in this paragraph.

If the sequencing of construction activities within each phase is different than what is called for in Section 6.1.3.3 of this Chapter then a description of those changes shall be required.

6.1.4.8 Maintenance and Inspection Requirements

This section shall identify all requirements that will be followed for maintenance and inspection of the selected Control Measures on the project.

6.1.4.9 Final Vegetation and Stabilization

This section shall identify the final means of stabilization and the final steps to complete the close out of the project in a timely manner.

The section shall at a minimum describe:

- 1) The means to return the exposed dirt to a stabilized condition, one that will not continue to result in erosion or sediment transport.

6.0 Erosion Control Material Requirements

- 2) All areas that will require immediate vegetation installations and plantings shall include:
 - Soil bed preparation activities in accordance with City Code, Section [12-160 through 12-162](#), and recommended additions to the soil
 - Planting method and schedule
 - A discussion about how and when such areas will be considered stabilized.
 - A referral to the approved landscape plan and City Landscape Standards (LUC 3.2.1 (3))
- 3) All areas that will require seeding (either temporary or permanent) shall include:
 - Soil bed preparation activities in accordance with City Code, Section [12-160 through 12-162](#), and recommended additions to the soil
 - A selected seed mix based upon the landscape plan and City Landscape Standards (LUC 3.2.1 (E) (All provided seed mixes shall include the Species Name, Common Name, Seed Application Rate (lbs. of PLS/acre), and Drill Depth) or a referral to look for the seed mix called out for in the landscape plan.
 - An explanation of the seeding method and schedule
 - An explanation of the crimping and mulching method that shall be applied within 24 hours after seeding, and
 - A discussion about how and when such areas will be considered finally stabilized. (Refer to Section 5.6 of Appendix D for an example discussion).
- 4) Estimated timeline for stabilization of each of the exposed areas (immediate, seasons, years).
- 5) A discussion of sediment removal from all pipes, drainage ways and other stormwater structures. Describe how the sediment will be disposed of correctly before the last remaining temporary Control Measures are removed from the project and the project has achieved final stabilization.

For further information, see Section 5.6 of Appendix D.

6.1.4.10 Appendix

This section of the report shall include any referenced materials mentioned in the Erosion Control Report.

6.0 Erosion Control Material Requirements

This section shall also, if not included earlier in the report, contain a separate appendix with a copy of each of the Control Measures or practices mentioned in the report in full detail. This is the detail sheets section specific to this project and shall include only those sheets that are called to be used on the project and shall be either: an accepted Control Measure detailed in Section 6.0 of Chapter 4 or Appendix E, an accepted proprietary Control Measure in accordance with Section 4.5 of Chapter 4, or a documented alternative in accordance with Section 5.1 of Chapter 4.

6.1.5 Erosion Control Escrow

An Erosion Control Escrow shall be required of all projects that are not exempt from the Erosion Control Materials requirements, as set forth above. (Note that the “Erosion Control Escrow” is separate from the “Drainage Certification Escrow”, which is addressed in this Manual in Section 4 of Chapter 3: During and Post-Construction Requirements). The Erosion Control Escrow shall be calculated, collected, managed, and returned or retained (as appropriate), pursuant to the terms and conditions of this Manual.

Amount of the Erosion Control Escrow for a Project

The amount of the Erosion Control Escrow for any project (before any refinement for phasing, as discussed below) shall be the greater of:

1. the cost to install all the approved Control Measures multiplied by 1.5;
2. the cost to re-vegetate the disturbed land to dry land grasses times multiplied by 1.5, or
3. the minimum Erosion Control Escrow amount, which shall be one thousand five hundred dollars (\$1,500) for a residential development or three thousand dollars (\$3,000) for a commercial development. Any residential multifamily developments (condos, apartments, townhomes, etc.) shall be considered commercial development for the purposes of the Erosion Control Escrow.

Developer’s Submittal of Erosion Control Escrow Calculations

A Developer’s calculations of the amount of the Erosion Control Escrow shall be located in one of the following locations upon submittal:

- as a section within the Erosion Control Report; or
- as a stand-alone document

The Developer shall submit an Erosion Control Escrow calculation sheet provided or approved by FCU. The calculation sheet must include project specific Control Measures and project areas. Example calculation sheets can be found and adapted for any project at www.fcgov.com/Erosion by looking for "[Example Erosion Control Escrow \(Security\) Calculation](#)". The calculation sheet shall set forth all calculations related to the amount of the Erosion Control Escrow.

The Developer is strongly encouraged in the submittal to break the project into phases, with specific proposed amount of the Erosion Control Escrow for the entire project allocated to specific phases and/or areas of the project, with specific Control Measures for such phases and areas. This will facilitate the project being segmented for the purposes of the Erosion Control Escrow, such that specific areas that may become stabilized before others so that parts of the Erosion Control Escrow can be released.

6.0 Erosion Control Material Requirements

One example would be a project with both areas that are laid with sod and native seeded; the benefit of breaking a project into phases is that when the sod phase is complete, the portion of the Erosion Control Escrow allocated to that area by FCU can be released before waiting on the native seed area to fully grow in, which could be years later.

If phasing a project, the Developer shall include the following in the submittal:

1. An Erosion Control Escrow calculation for each phase. The calculation shall be identical to the above method to evaluate the amount of the Erosion Control Escrow, including the amount for individual lots and parcels.
2. A map clearly showing the boundaries of each phase. (This may also be an exhibit in the Development Agreement to mark what areas each portion of the Erosion Control Escrow is earmarked for, this will also be used to determine if the area shown, and corresponding portion of the Erosion Control Escrow allocated to a phase, can be released). An example is shown in Section 6.2 of Appendix D.

FCU Review of the Developer's Submittal and Determinations

FCU shall review the Erosion Control Escrow calculation sheet(s) submitted by the Developer. FCU retains the right to make or require corrections to any submitted calculation sheet at any time. FCU further reserves the right to establish phases of the project for the purposes of the Erosion Control Escrow.

FCU shall inform the Developer, in writing, of the amount of the Erosion Control Escrow for the entire Project, as well as the amounts of the Erosion Control Escrow for phases of the project and the approved Control Measures for each phase or project. FCU will work with the Developer to address any concerns the Developer may have. Appeals of FCU's determinations may be made pursuant to Section 26-520 of City Code.

Any residential individual lots less than 10,000 square feet may be allowed to provide the Erosion Control Escrow for a project based upon the minimum Erosion Control Escrow amount without evaluating the Control Measures and reseeded, as residential individual lots have relatively few Control Measures, or reseeded cost associated with them, and the minimum escrow on these lots should be incentive enough to make sure the lot will comply with escrow requirements. These typically apply in instances where the residential subdivision has no Developer currently associated with the project or are infill housing located within a sensitive area and/or along a steep slope.

Collection of the Erosion Control Escrow

The entire amount of the Erosion Control Escrow for a project shall be submitted to FCU in a form that is acceptable to FCU. At the time the Developer submits the Erosion Control Escrow to FCU, the Developer shall sign a form provided by FCU acknowledging the Erosion Control Escrow provisions of this Manual, unless the Developer has already signed a Development Agreement with the City concerning the Erosion Control Escrow for the project. At the time the Developer submits the Erosion Control Escrow to FCU, the

6.0 Erosion Control Material Requirements

Developer shall provide a form provided by FCU that has been signed by the owner of the subject land authorizing FCU to enter onto the property for any and all purposes related to the Erosion Control Criteria.

Guarantee

The Developer shall guarantee (with Erosion Control Escrow as an assurance) that the temporary Control Measures shown on the approved Erosion Control Plan are properly constructed, installed, and are maintained free from defective materials and/or workmanship, with said guarantee to continue until the Control Measures can be removed.

The Developer shall guarantee (with Erosion Control Escrow as an assurance) and maintain all permanent Control Measures and vegetative measures for two growing seasons after installation or until permanent established vegetation has been reached, whichever is longer.

Any acceptance of installed measures (temporary, permanent, or vegetative) or returning of all or portions of the Erosion Control Escrow shall not be construed to relieve the Developer of the duty to maintain the installed vegetative measures as aforesaid.

Return of the Erosion Control Escrow – Completion of Requirements

All requests to release any portion of an Erosion Control Escrow, either for a particular phase or for the entire project, shall only be considered by FCU after all construction activities have ended on that particular phase or project.

The Erosion Control Escrow for a particular phase or for the entire project shall not be released until the phase or entire project is fully built, final grades are established, and the project has reached Final Stabilization as shown in the final plans. Specifically, the Erosion Control Escrow will not be released until every subject house, building, and public space is graded, built on, and stabilized in its final designed condition within the phase or project entirely (i.e. not temporary seeding, installation of seeding or cover crops, but final stabilization as designed to be in their final condition and in all areas delineated as part of the project).

These requirements are in place, in part, to prevent against Developers on partially completed projects leaving without any assurances that the project will not cause a pollutant issue and to prevent against Developers from neglecting site conditions that have the possibility to release pollutants from the project.

All parties who have deposited the Erosion Control Escrow are responsible and accountable for all areas disturbed by the respective construction activities until such time as the project has achieved final stabilization or another party supplies the Erosion Control Escrow in the same amount as the predecessor as a substitute for the original Erosion Control Escrow.

For examples on calculating the Erosion Control Escrow or Phase Calculation of the Erosion Control Escrow, refer to Section 6.1 and 6.2 of Appendix D.

Party the Erosion Control Escrow Will Be Returned To

FCU shall return the Erosion Control Escrow, or portions thereof, to the person or entity that paid the Erosion Control Escrow unless and until a notarized assignment of the rights to the Erosion Control Escrow is delivered to and approved by FCU identifying the new party that is entitled to all or portions of the Erosion Control Escrow. It is thus the responsibility of the other parties to arrange for the transfer of rights to the Erosion Control Escrow, or to replace certain Erosion Control Escrow of one party with those of another.

In the event the Developer sells the property or a lot within the property for which an Erosion Control Escrow has been delivered to FCU, the determination of who should supplement or take ownership of the rights to the Erosion Control Escrow shall be resolved entirely by the Developer and the new party; this shall not be the City's responsibility to calculate, evaluate, or phase a project and substitution of the Erosion Control Escrow.

Residential projects, which plan on selling off lots, or whole blocks, to a builder, or to various builders, should plan for the use of phases of a project prior to completing a review process. These areas to be sold off should be calculated into phases for the purposes of the Erosion Control Escrow so that the future buyer(s) is able to substitute their own Erosion Control Escrow in lieu of the Developers' Erosion Control Escrow .

In any case, how the Erosion Control Escrow shall be resolved is entirely by the Developer and the new party to determine who will be responsible for what and how long; this shall not be the City's responsibility to calculate, evaluate, or phase a project and substitution of Erosion Control Escrow.

If all or portions of an Erosion Control Escrow for a project is not used by the City as described below, is not requested to be released as described above, or is otherwise not claimed, the City retains the right to seek that all or portions of the Erosion Control Escrow are or have been abandoned and forfeited, to seek rights to the Erosion Control Escrow following any procedures required by law. See City Code Sections 23-131 through 23-138 (Intangible Personal Property).

City Use of Erosion Control Escrows

The City shall have the right to all or a portion of the Erosion Control Escrow for a phase or project if the Developer has not completed the required tasks identified in the Erosion Control Materials for that phase or project, pursuant to the following procedures.

If the Developer has not satisfactorily completed required tasks identified in the Erosion Control Materials for a project or a particular phase of a project, FCU shall provide written notice to the Developer no less than seven (7) calendar days prior to seizing all or a portion of the Erosion Control Escrow. Such notice shall include, at minimum:

- (1) the required tasks identified in the Erosion Control Materials for a project or a particular phase of a project that have not been satisfactorily completed;

6.0 Erosion Control Material Requirements

- (2) the actions that the Developer must take to satisfactorily complete such tasks;
- (3) the date that such tasks must be satisfactorily completed in order to avoid seizure of the Erosion Control Escrow (this date is provided solely as notice of a date certain when the Erosion Control Escrow will be seized and in no way authorizes the Developer to remain out of compliance with any obligations for any purpose); and
- (4) the amount of the Erosion Control Escrow that will be taken.

Failure to take the actions required in such notice shall entitle the City to seize the portions of the Erosion Control Escrow identified in the notice. The date provided in the notice when the tasks must be satisfactorily completed (item (3) above) is provided only for purposes related to the seizure of the Erosion Control Escrow; in no way does it, authorize the Developer to remain out of compliance and in

Nothing herein shall be deemed to preclude the City from taking any other action with respect to the Control Measures and matters associated with the project. If the City exercises its rights to the Erosion Control Escrow or pursues any other legal remedy, the City is not thereafter obligated to routinely administer the construction of the Control Measures as shown on the Erosion Control Material.

6.2 Submittals, Review and Acceptance of Construction Drawings

All projects shall be reviewed by FCU to meet requirements and standards with regards to this Chapter to ensure a project meets the requirements to begin Construction Activities.

A criteria-applicable project may be prevented from continuing through the Development Review Process, being granted approval to attain permits or begin construction until adequate materials are reviewed for content and accepted in accordance with the criteria set forth in Section 4.0 of this Chapter.

Outstanding comments on Erosion Control Materials, or failure to submit Erosion Control Materials, may result in “rejection” or “hold” on a project until the required items are submitted or comments are addressed. Once addressed and resolved to the satisfaction of the City the project may continue progression towards permitting and construction.

No projects are allowed to progress to permitting (Development Construction Permits, Stockpile Permits, Excavation Permits, or Building Permits) or begin construction until Erosion Control Materials have been reviewed and accepted.

If disputes around the criteria arise, FCU will seek to address them on a case-by-case basis.

6.2.1 Submittal Check lists of Erosion Control Requirements

A copy of the most up to date Erosion Control Requirements checklist is available at www.fcgov.com/erosion.

6.3 State and Federal Requirements and Programs Applied Locally

These following sub sections address the applicability of State requirements and other programs as they relate to the City of Fort Collins' local erosion control program.

6.3.1 State Permit: Stormwater Discharges Associated with Construction Activities

Nothing in these criteria impacts the requirements related to the State Permit "CDPS General Permit Stormwater Discharges Associated with Construction Activity" or the EPA's NPDES Construction General Permit.

6.3.2 Qualifying Local Program

A few municipalities across the State have been authorized by CDPHE to run programs that are accredited with CDPHE's approval to implement a Qualifying Local Program. With that accreditation, local municipalities are allowed to implement the permit for Stormwater Discharges associated with Construction Activities on CDPHE's behalf for projects disturbing less than five acres.

The City of Fort Collins is not a Qualifying Local Program at this time.

As the City is not a Qualified Local Program any acceptances of Materials based on City Criteria is not a valid approval of construction without the appropriate State permit from CDPHE "CDPS General Permit Stormwater Discharges Associated with Construction Activity".

6.3.3 Rainfall Erosivity Waivers

CDPHE provides a Rainfall Erosivity Waiver for projects that meet specific conditions such as: soil conditions that are just right, the timing of construction has a typical average rainfall that will not tremendously impact the project, and length of construction scheduled are in correct proportions that a project can then be placed in low risk category and can qualify to not be required to pull a CDPS General Permit Stormwater Discharges Associated with Construction Activity.

Having a Rainfall Erosivity Waiver for exclusion from State permitting does not relieve the Operator or Owner from meeting these Criteria for producing and submitting Erosion Control Materials to the City.

6.3.4 Oil and Gas Operations & Exploration

Facilities associated with oil and gas operation and explorations are not exempt from this Manual.

City Code Section [§12-135](#) and [§12-136](#) should be followed for Hydraulic Fracturing.

6.3.5 Chemical Removal of Sediment Laden Water from Construction

The City neither recommends nor permits the use of chemical treatments to remove sediment for Construction Activities. This permitting will need to be done through CDPHE and any other applicable state, federal, or local agencies.

6.4 Erosion Control in the Development Review Process Map

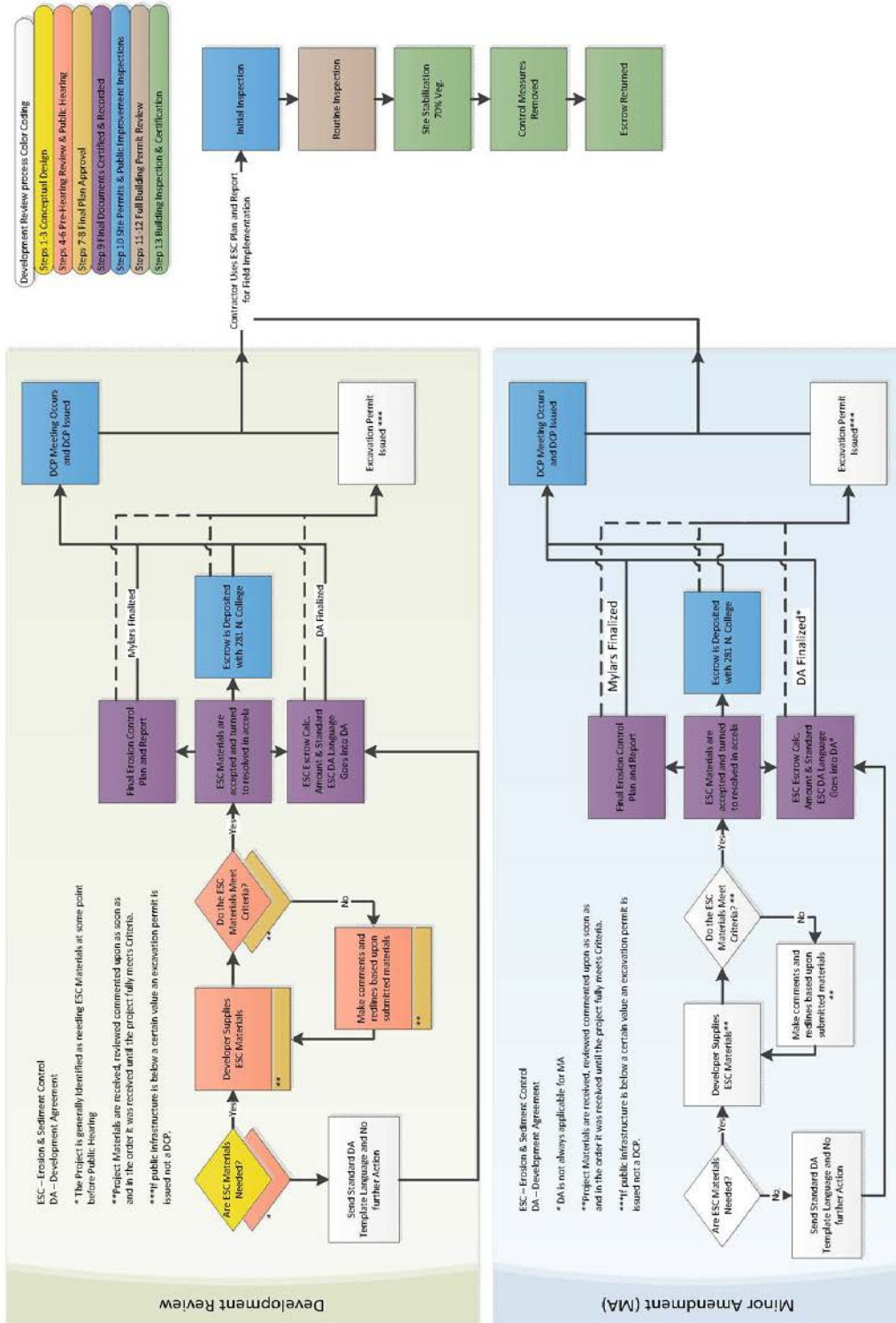

6.0 Erosion Control Material Requirements

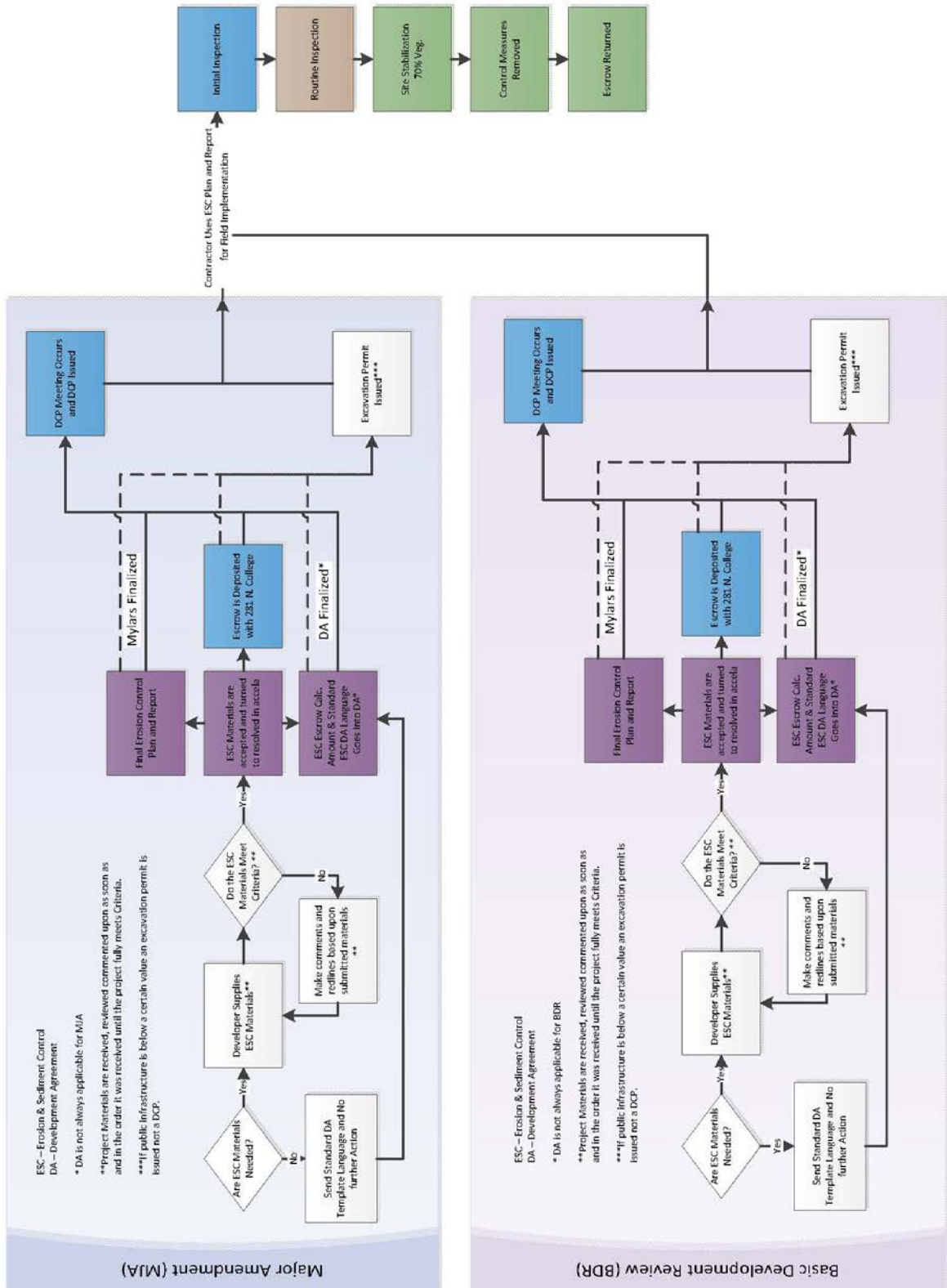

6.0 Erosion Control Material Requirements

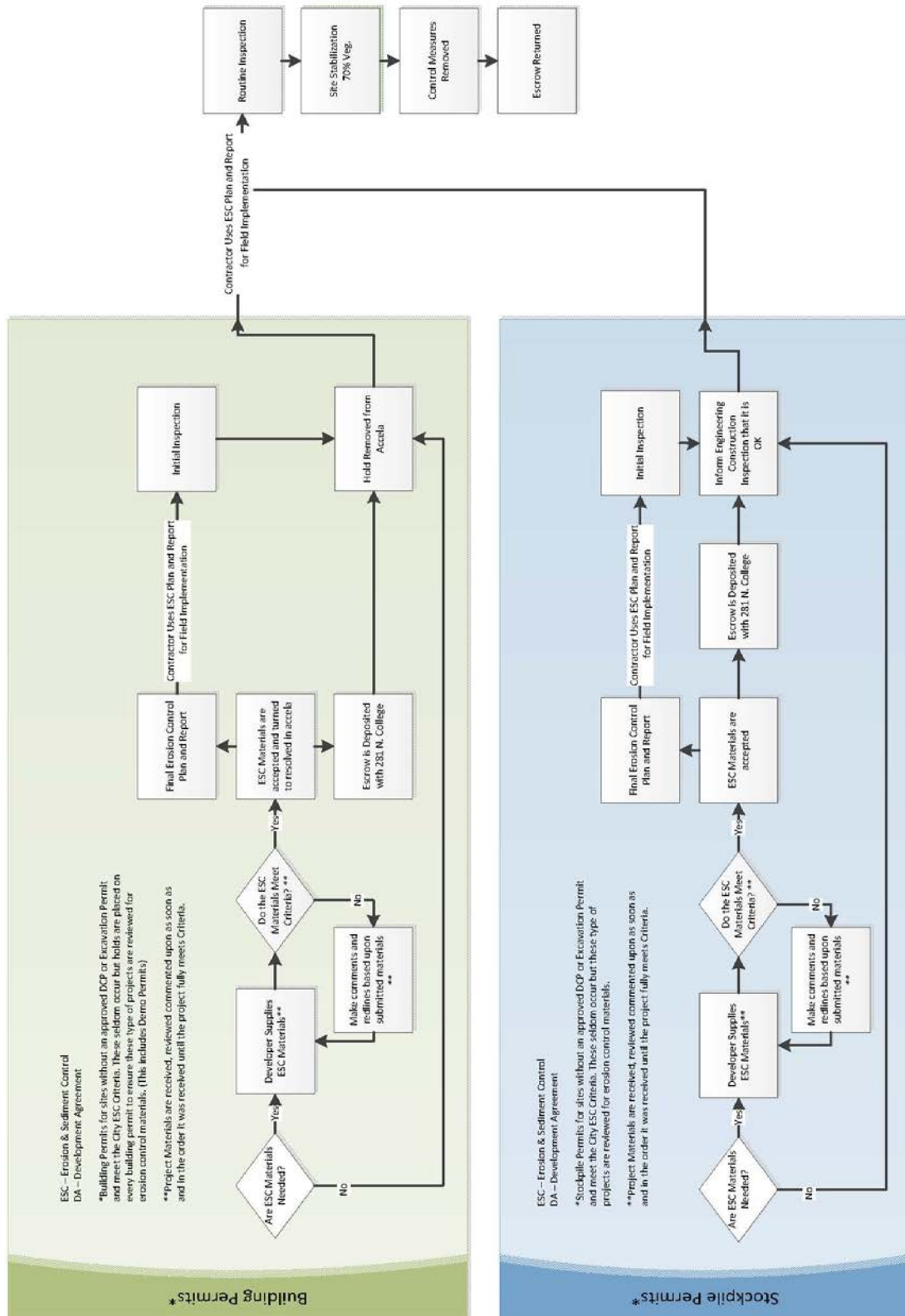

6.0 Erosion Control Material Requirements

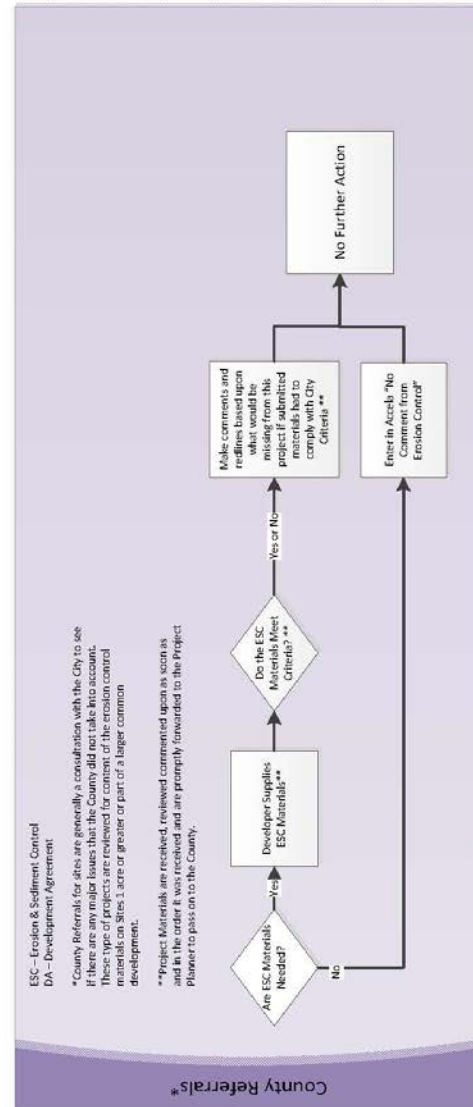
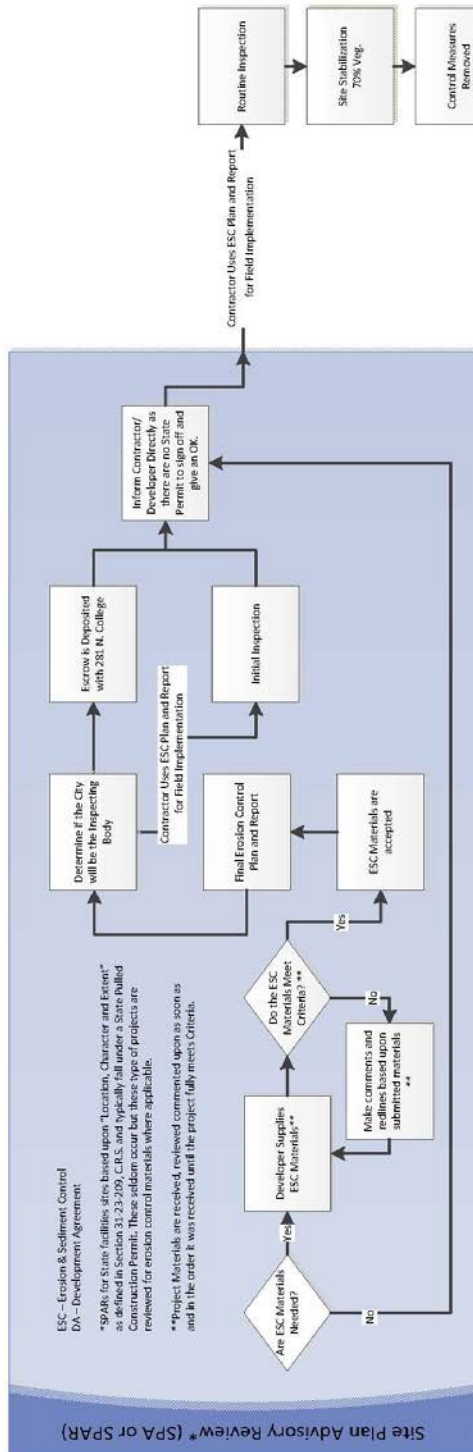

7.0 Floodplain Modeling Reports

An analysis and review of floodplain modifications may be necessary if development is proposed to modify a FEMA regulated or City regulated floodplain or floodway. All requirements of Chapter 10 of the City Code must be satisfied.

[Document Reference:](#) All floodplain modeling requirements identified in the [“Guidelines for Submitting Floodplain Modeling Reports”](#) must be completed and submitted.

8.0 Variance Request Process

Any design that does not conform to the criteria set forth in this Manual must be approved by the Utilities Executive Director as a variance. Variances from these criteria will be considered on a request-by-request basis following the submission of a written request for a variance pursuant to the requirements of this section.

8.1 Advisory Consideration of Draft Variance Requests

To assist with plan preparation, in coordination with FCU staff, the Design Engineer may submit draft variance requests, along with documentation in support of the draft variance request, for informal advisory consideration prior to formal submittal of the variance request. Any discussions, analyses and other communications made by FCU during such advisory consideration of a draft variance request shall not be binding on FCU in any way, including with respect to a subsequently filed variance request.

8.2 Variance Request Requirements

Variance requests shall be signed by the applicant and prepared and signed by a Professional Engineer and provided to the Utilities Executive Director. Variance requests shall be provided on the Stormwater Alternative Compliance/Variance Application form.

The variance request shall include, at minimum, the following:

- 1) **Identifying Issue:** Identification of the criteria or standard sought to be varied and a summary of the reason(s) that the applicant believes the standard should not be applied in this instance.

8.0 Variance Request Process

- 2) **Proposed Alternate Design:** Identification of the proposed alternate design or construction criteria, in the form of an exhibit showing the alternate design, narrative describing the alternate design, and/or analyses of the alternate design
- 3) **Comparison to the Subject Criteria or Standard:** A thorough analysis of the prescribed and alternative designs, including, at a minimum, the following:
 - a. Comparisons of the ability of the prescribed and alternative designs to meet the purposes and substantive requirements of this Manual.
 - b. Comparison of the capital and maintenance requirements of the prescribed and alternative designs
 - c. Comparison of the costs for the prescribed and alternative designs and how the proposed design compares to the criteria or standard sought to be varied.
- 4) **Justification:** The variance request must set forth the reason(s):
 - a. Why the criteria or standard sought to be varied is not appropriate for this instance.
 - b. Why the requested variance will not be detrimental to public health, safety and welfare.
 - c. How the proposed, alternative design will meet or exceed the substantive requirements of this Manual, and where the proposed alternative design will not and why not meeting such substantive requirements is appropriate.
 - d. Why the proposed alternative design will not reduce the design life of the improvement nor cause FCU additional maintenance costs.
 - e. How the proposed alternative design would advance the public purpose of the Manual in a manner equal to or better than the prescribed design under the criteria or standards sought to be varied.

8.3 Review of Variance Requests

The Utilities Executive Director will review variance requests following their submission. In addition to the variance request requirements listed above and as may be required for certain variances as stated elsewhere in this Manual, the Utilities Executive Director and FCU staff may request additional information and analyses with respect to any variance request. The Utilities Executive Director may approve, approve with additional terms and conditions, or deny the variance request, which shall be in writing and include a summary of the basis for such determination.

8.0 Variance Request Process

If the variance request is approved, the Utility Plans will continue to be reviewed and approved within the typical review process. If the variance request is approved with terms and conditions imposed by the Utilities Executive Director, the Utility Plans, as modified, will typically continue to be reviewed and approved within the typical review process. If the variance request is denied, the Developer or Design Engineer may subsequently submit revised Utility Plans in compliance with this Manual. If a variance request is approved with terms and conditions imposed by the Utilities Executive Director or denied, a subsequent variance request may be submitted or an appeal may be sought pursuant to City Code Section 26-520.

Reference: The “Stormwater Alternative Compliance / Variance Application” may be provided to the Design Engineer upon request to the Stormwater Department.

DRAFT

Chapter 3: During & Post-Construction Requirements

Contents

- 1.0 Overview 1
- 2.0 Erosion Control Inspections and Field Requirements..... 1
 - 2.1 Construction Activity and Escrow Control Escrow 1
 - 2.2 Developer Inspections 2
 - 2.2.1 Frequency..... 2
 - 2.2.2 Inspection Records..... 3
 - 2.2.3 Erosion Control Administrator 4
 - 2.2.4 Developer Inspector Qualifications..... 5
 - 2.3 Initial Inspection Requests..... 5
 - 2.4 Maintenance 7
 - 2.5 Removal and Disposal of Temporary Measures 8
 - 2.6 Final Stabilization and Established Vegetation Criteria 9
 - 2.7 Municipal Inspections 12
 - 2.7.1 Initial Municipal Inspections 12
 - 2.7.2 Routine Municipal Inspections..... 12
 - 2.7.3 Complaint-Driven Inspection 12
 - 2.8 Enforcement..... 14
- 3.0 Drainage Certification 16
 - 3.1 Drainage Certification and Acceptance Process 16
 - 3.2 Overall Site and Drainage Certifications for Commercial Properties, Multi-Family Properties and Single-Family Residential Subdivisions 17
 - 3.3 Individual Lot Certifications 18
- 4.0 Drainage Certification Escrow..... 18
 - 4.1 Formal Request to Use Drainage Certification Escrow 19
 - 4.2 Calculating the Drainage Certification Escrow..... 19
 - 4.2.1 Commercial or Multi-Family Site Drainage Certification Escrow..... 20
 - 4.2.2 Single Family Residential Site Drainage Certification Escrow 21
 - 4.3 Submittal and Review of the Drainage Certification Escrow 22

Chapter 3: During & Post-Construction Requirements

- 4.4 Guarantee 23
- 4.5 Return of the Drainage Certification Escrow 23
 - 4.5.1 Party the Drainage Certification Escrow Will Be Returned To..... 23
- 4.6 FCU Use of the Escrow 24
- 5.0 Close-Out Process 24
 - 5.1 Initial Close-Out Inspection Process..... 25
 - 5.2 Final Close-Out Inspection Process..... 26

1.0 Overview

The previous Chapter provided information on the development review process and submittal requirements for the entitlement of a project site from the very beginning of the design process through to the final approval of the Utility Plans and reports. This Chapter outlines standard procedures during the construction phase for Erosion Control Measure installations, inspections, and ongoing maintenance; outlines drainage certification requirements at or near the end of construction that enables the contractor or development team to receive building permits and/or certificates of occupancy (CO); and provides a process for calculating and submitting a Drainage Certification Escrow if building permits or CO is desired prior to the drainage certification being accepted by FCU.

2.0 Erosion Control Inspections and Field Requirements

The Owner(s) and Operator(s) of a construction site are responsible for all activities on the site related to erosion and stormwater, including, but not limited to, associated environmental impacts.

Routine and post-storm inspections of Control Measures are essential to identify maintenance that might be necessary for the Control Measures to remain in effective operating condition. The frequency of inspections is typically influenced by multiple factors including the weather, the phase of construction, activities on site, and the types of Control Measures. Checklists and other forms of inspection documentation are also important to meet the requirements of the CDPS General Permit Stormwater Discharges Associated with Construction Activity and are required by the City.

It is highly recommended that any persons working on the construction site undergo training for their roles and responsibilities regarding the control of potential site pollutant sources. They should be made aware how their work practices and implementation of various Control Measures on site help prevent those potential pollutant sources from leaving the site and entering the storm drains. Potential pollutant sources left uncontrolled can directly impact the water quality of the creeks, rivers, and streams.

Appointing a knowledgeable person to perform inspections with the authority to correct site issues is a key to a successful project and ensures that a project will be at minimal risk for compliance issues and enforcement actions.

2.1 Construction Activity and Escrow Control Escrow

Construction Activity subject to this Erosion Control Criteria is not permitted to commence or applicable permit able to be signed off, until all Erosion Control Materials have been reviewed.

2.0 Erosion Control Inspections and Field Requirements

All Construction Activity subject to the Erosion Control Criteria shall furnish an Erosion Control Escrow (as set forth in this Manual in Section 6.1.5 of Chapter 2 (Development Submittal Requirements)) prior to the installation of Construction Control Measures, the release of any construction permitting, and before any operations commence on the project. Refer to the process charts in Section 6.4 of Chapter 2: Development Submittal Requirements, to better understand the order of transition from development to construction based upon project review type.

The City reserves the right to enter upon the land and take whatever actions are necessary to stabilize and revegetate all disturbed areas, or to have Control Measures constructed and to make repairs as necessary.

In addition, the City shall have the option to pursue any other legal remedy available to it under any Development Agreement or otherwise as it deems necessary in order to ensure that the required Control Measures are installed, implemented, and preventing potential off site pollutant discharge, in accordance with [City Municipal Code, §26-498 and other applicable laws](#).

For further discussion of the Erosion Control Escrow, please refer to Section 6.1.5 of Chapter 2.

2.2 Developer Inspections

All Construction Activities subject to provide an Erosion Control Report as shown in Table 6.1-1 in Chapter 2 shall be required to conduct self-inspections by the Developer.

All Construction Activities that were not subject to provide an Erosion Control Report as shown in Table 6.1-1 in Chapter 2 should be conducting self-inspections by the Developer. If site conditions are found in non-compliance the Developer more than once, FCU shall have the discretion to require to self-inspections by the Developer.

2.2.1 Frequency

Table 2.2.1-1: Inspection Frequencies

Project’s Current Activity Level	Routine Inspection Intervals	After Storm Event
During Construction	14 days	24 hours
Temporary Idle Site	14 days	72 hours
Revegetation (post-construction)	30 days	None

Documented inspections by the Developer shall be conducted at least once every fourteen (14) calendar days and within twenty-four (24) hours of a storm event during construction.

2.0 Erosion Control Inspections and Field Requirements

Documented inspections by the Developer shall be conducted at least once every fourteen (14) calendar days and within seventy-two (72) hours of a storm event while a site is temporarily idle where no construction activities will occur.

Documented inspections by the Developer shall be conducted at least once every thirty (30) calendar days after construction is completed and the site is waiting for reseeding to reach final stabilization. The Project should not have any Construction Activities occurring and only be waiting for grass to grow to full maturity.

All changes from one inspection frequency to another inspection frequency shall document the change in site condition through photos or other justification to the change the frequency in accordance with relevant permit requirements from the State prior to reducing the inspection schedule.

Where construction activities have stopped and snow cover (over 12 inches) exists over the entire site and for an extended period (longer than 14 days), inspections are not always feasible. This condition shall be documented and an after-storm event inspection shall be conducted within twenty-four (24) hours of melting conditions or regaining access to the site.

All deficiencies discovered during an inspection are required to have the deficiency corrected and follow up inspection completed as soon as possible to document when the item was corrected.

The City recommends checking Control Measures every workday. This is typically reasonable to achieve and can help to ensure Control Measures remain in good working condition. For example, vehicle tracking of sediment onto the roadway is a common problem that often requires maintenance more frequently than weekly. Curb socks, inlet protection, and silt fence are other BMPs that are prone to damage and displacement, also benefiting from more frequent inspections, the recommended frequency of inspection is at least once every week). When the site or portions of the site are awaiting final stabilization (e.g., vegetative cover), where construction is essentially complete, the recommended frequency of inspection is at least once every month.

2.2.2 Inspection Records

Always check the requirements of all permits for required documentation of specific inspection items.

The inspection records shall contain at a minimum:

- 1) Date and time of inspection
- 2) Personnel conducting the inspection
- 3) Project name and location

2.0 Erosion Control Inspections and Field Requirements

- 4) Reason for inspection (Ex. after installation, routine inspection, after precipitation, weekly etc.)
- 5) Include last stormwater event and amount of precipitation
- 6) Date of when melting conditions occur (if applicable)
- 7) Evaluation of all potential pollutant sources
- 8) Evaluation of all Control Measures implemented on site
- 9) An area to note Control Measures failures
- 10) Observed deviations from the Erosion Control Materials/SWMP
- 11) Necessary future planned repairs or corrective measure
- 12) Corrective actions taken and when
- 13) Any identified any spills (This includes small oil drips to larger spills)
- 14) General observations

Records of inspections must be kept available by the Developer and submitted to the Erosion Control Inspector upon request.

All inspection records shall be kept in order or easily referenced and retrieved by the Developer for all inspecting parties.

Refer to Section 7.8.1 of Appendix D for further direction and clarification.

2.2.3 Erosion Control Administrator

For further guidance please see Section 7.8.2 of Appendix D.

The Erosion Control Administrator shall be responsible to keep Erosion Control Materials and inspection records (Section 2.2.2 of this Chapter) up to date and reflect the current field conditions.

The Erosion Control Plan should, at all times, be drawn, amended, noted, or otherwise rendered to reflect the exact current field conditions.

2.0 Erosion Control Inspections and Field Requirements

Minimizing disturbance where possible, phasing a project, preserving vegetation as long as possible, and not storing material with exposure to stormwater where able are all preventative administrative measures that should always be at the forethought of a good administrator's mind.

An Erosion Control Administrator shall be accountable to ensure:

- The inspection process is documented
- A schedule is developed describing the required frequency of inspections
- Regular inspections occur at the prescribed frequency
- The Control Measures are kept up and maintained
- A schedule of inspections that did take place is kept
- Access to all inspection records and Erosion Control Materials in their dynamic construction state is available

2.2.4 Developer Inspector Qualifications

The City recommends all Developer inspectors have knowledge or understanding of potential pollutant sources and experience with methods for controlling those potential pollutants from the source.

At this time, there are no City requirements to have a minimal level of training or certification to oversee and manage a construction site for Erosion Control Management, inspection, and maintenance purposes.

While there is no minimum level of knowledge or understanding of erosion control procedures or concepts, the City highly recommends everyone have erosion control training, as the regulations continue to become more scrutinized on construction sites. Added levels of scrutiny will occur, not just at the City level, but also by the State and Federal level. Ignorance of the regulations and/or rules is not an excuse to allow potential pollutant, or cause pollutant, discharges into the environment. All government entities can enforce on these violations to the extent of their own authority.

2.3 Initial Inspection Requests

Any project that is subject to the Erosion Control Criteria shall sequentially follow the relevant section below when requesting an initial inspection for the particular permitting process.

Development Construction Permits:

2.0 Erosion Control Inspections and Field Requirements

- 1) Deposit Erosion Control Escrow
- 2) Development Construction Permit (DCP) issued
- 3) Install Control Measures
- 4) Initial municipal inspection and acceptance by the FCU Staff
- 5) Start Construction Activities

Building Permit associated with a larger common development:

- 1) Deposit Erosion Control Escrow for the lot (or provide documentation regarding a substitution for the Erosion Control Escrow for the lot, if applicable)
- 2) Install individual lot protection
- 3) Initial municipal inspection and acceptance by the FCU Staff
- 4) Building Permit Issued
- 5) Start Building Activities

Building Permit not associated with a larger common development:

- 1) Ensure Erosion Control Materials meet Criteria
- 2) Deposit Erosion Control Escrow
- 3) Install Control Measures (even individual lots require lot level compliance)
- 4) Initial municipal inspection and acceptance by the FCU Staff
- 5) Building Permit Issued
- 6) Start Building Activities

Any other Permit Process that meet the Erosion Control Materials thresholds in Table 6.1-1 of Chapter 2:

- 1) Ensure Erosion Control Materials meet requirements of this Manual
- 2) Deposit Erosion Control Escrow (if applicable)
- 3) Install Control Measures
- 4) Initial municipal inspection and acceptance by the FCU Staff

2.0 Erosion Control Inspections and Field Requirements

5) Start Construction Activities

All requests for a municipal initial inspection should be sent at least twenty-four (24) hours prior to the start of any construction activities by email to erosion@fcgov.com all requests will be fulfilled within two (2) business days of receiving the request.

Please include the following information:

- Name
- Phone number
- Site Address
- Any building permits associated with the site, if known
- Date of installation (or anticipated date of installation) of the Control Measures, for verification

If there are any issues with the site Control Measures, the requesting party will be contacted to have those corrected.

If no issues were found at a development site (or another similar permit process) the Developer, or contractor, will receive an initial inspection report from noreply@mypermitrack.com the site has passed inspection and construction can commence.

If no issues were found at a building site the site will be signed off at the building department. The permit's release can be observed at the Citizen Access Portal <http://www.fcgov.com/building/>

2.4 Maintenance

The Developer shall, at all times, maintain Control Measures so that they function as intended to minimize the potential discharge of pollutants from the source.

All deficiencies in application, maintenance, and removal of Control Measures shall be corrected as soon as practical (typically immediately). "A specific timeline for implementing maintenance procedures is not included in this permit because BMP (*Construction Control Measures*) maintenance is expected to be proactive, not responsive" as in accordance with Section D.7 of the CDPS General Permit Stormwater Discharges Associated with Construction Activity.

2.0 Erosion Control Inspections and Field Requirements

Proactive maintenance is fundamental to effective Control Measure performance. Rather than maintaining the Control Measure in a reactive manner following failure, provide proactive maintenance that may help to reduce the likelihood of failure. The types and frequencies of maintenance are Control Measure specific. The Control Measure fact sheets in Section 6.0 of Chapter 4 describe the maintenance needs for various Control Measures, with some controls requiring more attention.

The Developer shall maintain Control Measures so that they function as intended, to minimize potential the discharge of pollutants from the source. Maintenance shall include:

- Proper installation of Control Measures as per design
- Identifying needed maintenance activities during site inspections or during general observations of site conditions
- Removing accumulated sediment before it limits the effectiveness of the Control Measure up to and including the removal of the Control Measure
- Where Control Measures have failed or approach failure, shall include repairs or changes should be initiated as soon as practical.

Where the Control Measures specified in the Erosion Control Material are not functioning effectively at the site, modifications must be made that may include different or additional layers of Control Measures. When new Control Measures are installed or Control Measures are replaced, check the permit for documentation requirements about the site plans matching the site conditions. This may require communication with the Owner and/or engineer and, at a minimum, should be documented in the inspection and maintenance records.

2.5 Removal and Disposal of Temporary Measures

All temporary Control Measures shall be removed by the Owner within thirty (30) days after confirmation by the FCU that the site has reached final stabilization.

Trapped sediment (including in pipes) shall be removed and disposed of, by the Owner, in accordance with proper disposal practices and if necessary disturbed soil areas resulting from the disposal of temporary measures shall be returned to final plan grades and permanently stabilized to prevent further soil erosion.

All permanent Control Measures used for temporary Control Measures during construction shall return to a condition identical to the details specified in the final site development plans as prepared by the Design Engineer.

2.0 Erosion Control Inspections and Field Requirements

Refer to Section 7.9 of Appendix D for further guidance.

2.6 Final Stabilization and Established Vegetation Criteria

Final Stabilization shall be reached when:

- All construction activities have been completed
- All construction related potential pollutant sources have been removed from the site
- All site grades are final
- All soil beds have been prepped to meet [City Code, Section 12-160 through 12-162](#)
- All areas of ground surface disturbances have a permanent established vegetation or equivalent permanent physical erosion reduction method
- The site matches the final condition on all final design documents

Physical evidence of established vegetation shall include no larger than one (1) square foot of bare spots between grass and a minimum of seventy percent (70%) uniform vegetative cover (or grass density) as observed from about 5 feet above the vegetation looking down onto the area directly below. The seventy percent (70%) shall neither be a measure of area on a project nor the measure of horizontal density observation.

Temporary vegetation, annual crop, or cover crop shall not be considered permanent established vegetation.

Sod installation for permanent established vegetation purposes is considered a hundred percent (100%) uniformed vegetative cover. Bare soil for permanent established vegetation purposes is considered a zero percent (0%) uniformed vegetative cover.

Seeding applications for permanent established vegetation purposes require evaluation to determine if it is considered seventy percent (70%) uniformed vegetative cover.

Seeding and Planting

- Seed mixtures shall be sown at the proper time of year specified for the mixture

2.0 Erosion Control Inspections and Field Requirements

- Recommended seeding rates specified as “pounds pure live seed per acre” (lbs. PLS/acre) as called out on the landscape plan shall be used. If no landscape plan was required or approved as part of this construction, the City Natural Areas “Dry Land Seed Mix” should be used
- Seed shall be drill seeded, whenever possible. Native seeding should use a rangeland style drill to place seed at the proper depth add proper germination
- Broadcast seeding or hydro-seeding may be substituted on slopes steeper than 3(H):1(V) or on other areas not practical to drill seed
- Seeding rates shall be doubled for broadcast seeding or increased by 50% if using a Brillion drill or hydro-seeding
- Broadcast seed shall be lightly hand raked into the soil
- Seed depth shall typically be ¼ to ½ inch for most mixtures and the appropriate and optimum depth shall be determined based upon seed species
- All seeded areas shall be mulched within 24 hours of seeding, and the mulch shall either be adequately crimped and or tackified
- If hydro-seeding is conducted, mulching or tackifier shall be conducted as a secondary and entirely separate application
- The seed shall not contain any [Colorado noxious weeds](#) as defined by the Colorado Department of Agriculture.

Mulching

All planted areas must be mulched within twenty-four (24) hours after planting. Mulch conserves water and reduces erosion. The most common type of mulch used is hay or grass that is crimped into the soil to hold it. However, crimping may not be practical on slopes steeper than three to one (3H: 1V).

The following guidelines shall be followed with mulching:

- Only weed-free and seed-free straw mulch may be used. Mulch shall be applied by recommended manufacture’s installation details. In the absence of manufacturer’s instructions, mulch shall be applied evenly at a rate of 2 tons per acre and 50 percent of the straw by weight should be 10 inches or more in length.

2.0 Erosion Control Inspections and Field Requirements

- Crimping shall be applied on appropriate slopes of three to one (3H : 1V) or flatter. Mechanical crimpers must be capable of tucking the long mulch fibers into the soil to a depth of 3 inches without cutting them.
- Tackifier or netting and blankets anchored with staples shall be used on slopes steeper than (3H:1V).
- Hydraulic mulching may also be used on steep slopes or where access is limited. In these circumstances, wood cellulose fibers or similar organic tackifier materials, mixed with water at the ratio prescribed by the manufacture may be applied. This must be applied with a hydraulic mulcher.
- Wood chip mulch should be applied to planted trees and shrubs.

Maintenance

- Sites shall be routinely inspected following planting to implement follow-up measures to increase success. Immediate attention to a problem (e.g., weed infestation, failure of seed to germinate) can prevent total failure later.
- Areas that have been planted or seeded shall be monitored at least one spring and one fall season to ensure that physical evidence growth has been adequately established. If these minimums are not attained after one fall and one spring season, planted areas shall be re-seeded appropriately as soon as practical.
- Access to and grazing on recently revegetated areas should be limited with temporary fencing and signage while plants are becoming established (normally the first year).
- Weed infestations should be managed using appropriate physical, chemical, or biological methods as soon as possible.
- Stakes and guy wires for trees should be maintained and dead or damaged growth should be pruned.
- Mulch should be maintained by adding additional mulch and redistributing mulch, as necessary by site conditions.
- Areas of excessive erosion shall be repaired and stabilized.

Equivalent permanent physical reduction method shall be such things as buildings, structures, roads, sidewalks, rock landscaping, wood mulch, or the like that will eliminate rainfall impact on disturbed soil and creates a long term non-erosive cover to a project area.

2.7 Municipal Inspections

The City reserves its right to inspect and prevent potential pollutants from leaving a project and being introduced into the City's Stormwater Infrastructure pursuant to [City Code, Section 26-498](#) and other legal authority.

The FCU will conduct a municipal inspection used to verify if Construction Activities (which are identified as being at a higher risk of violating this section of municipal code) are preventing materials from being introduced into the MS4.

These municipal inspections in no way fulfill the Developer's obligations to inspect a site, per the requirements of this Manual, for the CDPS General Permit Stormwater Discharges Associated with Construction Activity. Those Developer inspections and requirements under that permit are to be conducted by the Developer.

These municipal inspections are to fulfill the City's obligations under the [State's general permit for stormwater discharges associated with Municipal Separate Storm Sewer Systems \(MS4\)](#).

2.7.1 Initial Municipal Inspections

All requests for an initial inspection received by email to erosion@fcgov.com. Each request will be fulfilled within two (2) business days of receiving the request.

Upon verification of the petitioning party preventing the risk of potential pollutant discharge from the project all appropriate permits will be signed off.

The project will then start routine inspections or be inspected as part of the larger site's routine inspections.

2.7.2 Routine Municipal Inspections

After an initial municipal inspection, the project will continue to be inspected based upon site conditions and complaints until the project has reached final stabilization and all Control Measures have been removed.

2.7.3 Complaint-Driven Inspection

2.0 Erosion Control Inspections and Field Requirements

Upon receiving a complaint, a City Erosion Control Inspector will visit the site of the complaint to investigate the issue(s) identified in the complaint and will conduct a site-wide inspection.

Where substantiated, the responsible party will be informed of the violation and a written inspection record (per PermiTrack email) will be provided to the Owner and/or the site contact. The responsible parties will be required to bring the site into compliance. If further escalation of enforcement is warranted, the City's Enforcement Response Plan will be consulted.

DRAFT

2.8 Enforcement

Preventing potential pollution from Construction Activities sources is a requirement of Developer in the Erosion Control Criteria which is a part of [City Code, Section 26-500](#).

FCU has the authority and obligation to ensure that any project is held in accordance with the Erosion Control Criteria before construction.

Preventing potential pollutant sources from leaving the site is mandatory of the Developer in order not to violate [City Code, Section 26-498](#).

The City reserves the right to enter upon the land and take whatever actions are necessary to stabilize and re-vegetate all disturbed areas, or to have the Control Measures constructed and to make repairs as necessary at the cost of the Developer.

Construction Activity subject to this Stormwater Criteria Manual (Table 6.1-1 of Chapter 2) shall begin only after:

- Erosion Control Materials have been accepted
- Submission of an acceptable security based upon Erosion Control Escrow
- An initial inspection of the site confirms the site is protected from risk

All Erosion Control Measures shall be installed when they are necessary as indicated by the approved Erosion Control Materials and maintained in accordance with these Criteria.

In order to ensure that all required Measures have been correctly installed and are in proper order and repair, no building permit will be issued on any project until an inspection of the site and its required Erosion Control Measures has been made and deemed acceptable by the City.

The Erosion Control Inspector understands that inspections are a "point in time inspection" and there is the expectation that all identified issues provided in the Municipal Inspections Section 2.9 of this Chapter will be addressed as soon as possible once identified. All simple corrections should be handled immediately and larger Control Measure issues that may take more time should be placed on an accelerated process to be corrected as soon as possible.

FCU has the authority and obligation to ensure that any project subject to the Erosion Control Criteria is held in compliance during construction and until final stabilization.

2.0 Erosion Control Inspections and Field Requirements

FCU has the authority so that if, at any time during Construction Activities, the Developer fails to adhere to the accepted Erosion Control Materials, the construction phase, the construction sequence, any of the Erosion Control Criteria and/or any site conditions that would or could violate [City Code, Section 26-498](#), the City representative, may employ any, all, or none of the following as deemed necessary to ensure that the project will return to an acceptable condition to prevent potential pollutant sources to discharges from the site:

- Letters of warning
- Require the routine response and proof of correction to future municipal inspections
- Require the routine submittal of future Developer inspection reports
- Required trainings of the Developer to ensure knowledge and application of Control Measures
- Provide and sign a corrective action plan to prevent future recalcitrant behavior
- Notices of violation
- Withhold permits (Building, Development, or other City Permits)
- Withhold certificates of occupancy
- Stop all or any part of the work on the project
- Exercise the City's rights to the erosion Control Escrow
- Issue summons and or fines

The City does not have the authority to give any permission to a Developer to be out of compliance with State and Federal law. The City will thus not give deadlines for compliance because, among other things, any such deadlines could be construed as purporting to give permission to the Developer to allow a time frame to be out of compliance with the Clean Water Act and the Colorado Water Quality Control Act. As per direction of State and Federal authorities, all Control Measures are to be corrected as soon as practical, and in many case, immediately.

Refer to Section 7.10 of Appendix D for more information on enforcement actions.

3.0 Drainage Certification

Figure 3.0 Drainage Certification Process

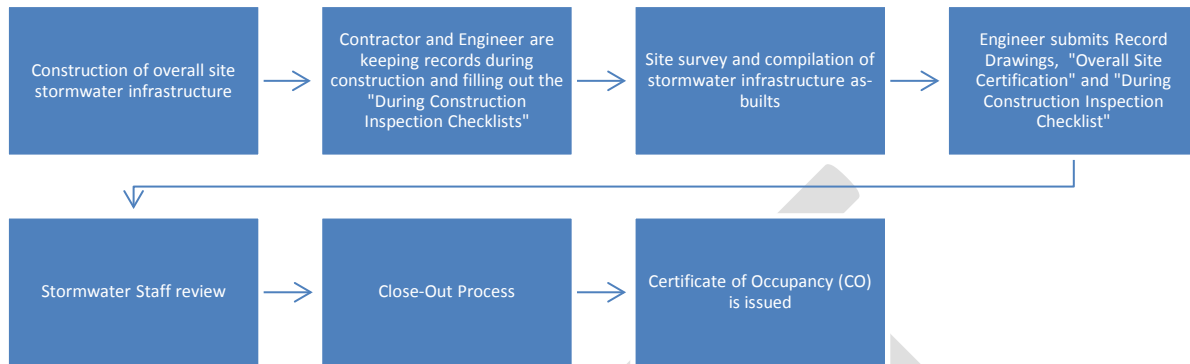

All developments are required to submit drainage certifications following construction, as discussed in this Chapter and as required by the Utility Plans and Development Agreement. Developers must acquire FCU acceptance of all such certifications. Specific additional requirements for overall site and individual lot certifications are set forth below.

3.1 Drainage Certification and Acceptance Process

During construction and prior to the drainage certification process, onsite inspections by a City Inspector is required for all permanent water quality improvements (including LID systems) associated with the development project. Inspection is performed to verify the proper installation of said improvements at specified stages of construction as indicated the During Construction Inspection checklists (discussed below).

CITY INSPECTION

REQUIRED AT SPECIFIED MILESTONES FOR ALL PERMANENT WATER QUALITY SYSTEMS (INCLUDING LID). CONTACT STORMWATERINSPECTION@FCGOV.COM TO SCHEDULE INSPECTIONS.

The submission for the Drainage Certifications shall include the following:

- Construction as-builts that have been formally submitted as Record Drawings and have been certified by both a registered Professional Land Surveyor and a registered Professional Engineer in the State of Colorado.
- Statement of compliance with the requirements of this Manual from the Professional Engineer on the project.

3.0 Drainage Certification

- The Overall Site and Drainage Certification checklist and accompanying documentation, and the During Construction Inspection checklist and accompanying documentation (if applicable).
- The Certification of Lot Grading forms (if applicable) for individual lots. The certification must show the designed and “as-built” conditions of the lot grading, including corner lot elevations, high points, side lot swales, drainage patterns, minimum building opening elevations and any other signification points on the site.
- All Floodplain certifications required by the City’s Floodplain Administrator must also be included. These may include FEMA Elevation or Flood-Proofing Certifications and No-Rise Certifications and or other documents as specified.

FOR COMMERCIAL AND MULTI-FAMILY PROJECTS
 OVERALL SITE AND DRAINAGE CERTIFICATION MUST BE ACCEPTED BY FCU BEFORE THE RELEASE OF THE FIRST CO.

FOR SINGLE-FAMILY RESIDENTIAL PROJECTS
 25% OF THE OVERALL NUMBER OF BUILDING PERMITS MAY BE ISSUED PRIOR TO ACCEPTANCE OF THE OVERALL SITE AND DRAINAGE CERTIFICATION

A certification will only be accepted by FCU if:

- The as-built information demonstrates that the construction complies with the approved Utility Plans. Any discrepancies between the original drainage plan and the constructed system need to be discussed with the FCU and shown to function within the criteria set forth in this Manual. If the construction does not comply with the criteria, the Professional Engineer on the project must redesign the drainage facilities and revise the Utility Plan mylars to correct the deficiencies. Alternatively, a variance request may be submitted and approved pursuant to Section 8.0 of Chapter 2: Development Submittal Requirements of this Manual.

[Reference: Floodplain certification document requirements are as specified in Chapter 10 of the City Code and can be found on the City website.](#)

3.2 Overall Site and Drainage Certifications for Commercial Properties, Multi-Family Properties and Single-Family Residential Subdivisions

The Overall Site and Drainage Certification must include certification of the drainage facilities shown on the approved Utility Plans. This includes drainage facilities such as:

4.0 Drainage Certification Escrow

- Water quality and quantity detention basin (volume, grading and elevation certification)
- Channels or swales
- Storm pipes and inlets
- Subdrain pipes
- Curb cuts, concrete pans, sidewalk culverts
- Site grading
- Erosion control installations
- Post-construction site cleanup

[Reference: Refer to the “Overall Site and Drainage Certification” and “During Construction Inspection” checklists.](#)

The Utility Plans, together with the Development Agreement, identify when and what facilities must be certified and how many building permits and/or COs are allowed prior to submitting the Overall Site and Drainage Certification.

For commercial and multi-family building projects, the Overall Site and Drainage Certification must be accepted before the release of the first CO. Twenty-five percent (25%) of the building permits in a single-family residential project can be issued prior to acceptance of the Overall Site and Drainage Certification, unless otherwise agreed to in the Development Agreement. The Overall Site and Drainage Certification must be submitted and approved by the FCU before the release of any remaining building permits is allowed.

3.3 Individual Lot Certifications

Certification of Lot Grading, by a Professional Engineer, is required as specified in the applicable Development Agreement, for individual lots to ensure lot grading was completed according to the approved grading plan.

[Reference: Refer to the “Certification of Lot Grading” checklist.](#)

4.0 Drainage Certification Escrow

4.0 Drainage Certification Escrow

City Code Section 26-544(b) provides for the use of escrow (referred to in this Manual as the “Drainage Certification Escrow”) in order to obtain a certificate of occupancy (CO) for property prior to construction, certification, and acceptance of stormwater facilities. (Note that the “Drainage Certification Escrow” is separate from the “Erosion Control Escrow”, which is addressed in this Manual in Section 6.1.5 of Chapter 2: Development Submittal Requirements). The Drainage Certification Escrow may be collected to assure construction, installation, and certification of the facilities in accordance with final development plan documents, such as a Development Agreement. Consistent with City Code Section 26-544(b), the following sets forth how the Drainage Certification Escrow shall be calculated, collected, managed, and returned or retained (as appropriate).

Figure 4.0 Drainage Certification Escrow Process Steps

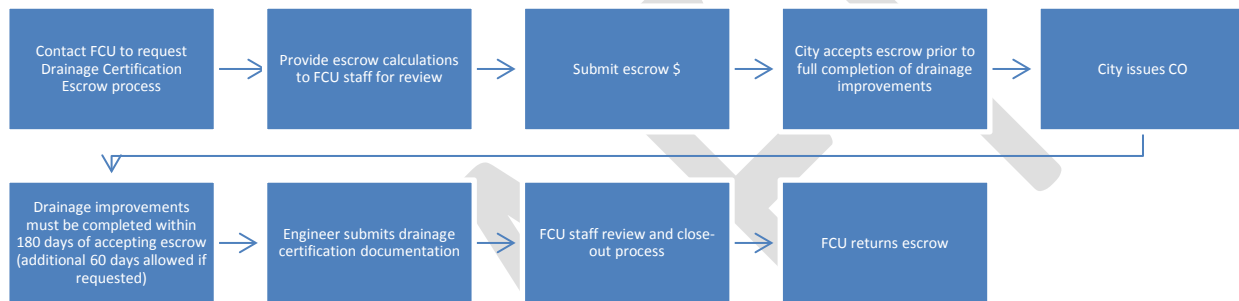

4.1 Formal Request to Use Drainage Certification Escrow

A formal request must be made to FCU for utilizing a Drainage Certification Escrow. This request may be discussed informally but must also be submitted in writing (including via email) in a formal request letter for recordkeeping purposes. Section 4.3 below discusses requirements of the formal request letter.

4.2 Calculating the Drainage Certification Escrow

- A non-refundable administrative fee of **\$200** per escrow to process and track the escrow will be applied to all projects seeking to utilize the Drainage Certification Escrow.
- For commercial or multi-family buildings and lots requesting CO, that can show completed construction, a Drainage Certification Escrow in the amount of **\$3,000** per lot may be provided to the FCU for the issuance of any CO prior to submitting and processing the Drainage Certification.
- For single family residential lots requesting CO, that can show completed construction, a Drainage Certification Escrow in the amount of **\$1500** per lot may be provided to the FCU for the issuance of the CO prior to submitting and processing the Drainage Certification for the lot.

4.0 Drainage Certification Escrow

4.2.1 Commercial or Multi-Family Site Drainage Certification Escrow

All sites requiring drainage and grading certification per the Land Use Code (see Land Use Code Division 3.3.2.E.1.e) must complete the certification in accordance with the associated site Development Agreement. If a CO is requested prior to site construction being completed or the drainage certification being processed, the following information must be provided prior to issuance of a CO.

- 1) Engineer’s Cost Estimate: A complete and accurate itemized list and estimated costs of drainage and/or grading improvements yet to be completed. This estimate is to be prepared, stamped, signed, and dated by a Professional Engineer licensed in the State of Colorado.
- 2) Commercial or Multi-Family Site Drainage Certification Escrow is calculated as shown in the following **Table 4.2.1-1**. This calculation is to be provided along with the Engineer’s Cost Estimate for review.

Table 4.2.1-1: Commercial or Multi-Family Site Drainage Certification Escrow

<p>1. Engineer’s cost estimate: Engineer’s cost estimate x 150% =</p>	<p>\$ _____ (1)</p>
<p>2. Certification cost: _____ # of site acres x \$50 =</p>	<p>\$ _____ (2a)</p>
<p style="padding-left: 40px;">If site does not include stormwater facilities: _____ building sq. ft. x \$0.05 =</p>	<p>\$ _____ (2b)</p>
<p style="padding-left: 40px;">If site includes stormwater facilities: _____ building sq. ft. x \$0.10 =</p>	<p>\$ _____ (2c)</p>
<p>Total of (2a) + (2b) + (2c) =</p>	<p>\$ _____ (2d)**</p>
<p><i>**If (2d) exceeds \$15,000, the amount shall be adjusted with the following formula:</i></p>	
<p>$(\\$15,000 + 50\% \times (\text{amount over } \\$15,000))$ = \$ _____ ***</p>	
<p><i>***If (2d) equals or exceeds \$25,000, the Water Engineering and Field Services Manager shall have the ability to reduce the amount.</i></p>	
<p>Greater of (2d) or \$3,000 =</p>	<p>\$ _____ (2)</p>

4.0 Drainage Certification Escrow

3. Non-refundable administrative fee:	\$ 200 (3)
Total Escrow = (1) + (2) + (3) =	\$ _____

This table is also available in spreadsheet format upon request.

4.2.2 Single Family Residential Site Drainage Certification Escrow

All sites requiring drainage and grading certification per the Land Use Code (see Land Use Code Division 3.3.2.E.1.e) must complete the certification in accordance with the associated site Development Agreement which will stipulate a maximum number of building permits allowed prior to requiring the drainage certification. If additional building permits are requested prior to the site being certified, the owner may obtain additional building permits under the following conditions:

- 1) Engineer’s Cost Estimate: An itemized list and estimated costs of remaining drainage and/or grading improvements per the Project Development Plans. This estimate is to be prepared, stamped, signed, and dated by a Professional Engineer licensed in the State of Colorado.
- 2) Single Family Residential Site Drainage Certification Escrow is calculated as shown in the following **Table 4.2.2-2**. This calculation is to be provided along with the Engineer’s Cost Estimate for review.

Table 4.2.2-2: Single Family Residential Site Drainage Certification Escrow

<p>1. Engineer’s cost estimate: Engineer’s cost estimate x 150% =</p>	\$ _____ (1)
<p>2. Certification cost: # of lots x \$75 =</p>	\$ _____ (2a)
<p># of site acres x \$50 =</p>	\$ _____ (2b)
<p>Total of (2a) + (2b) =</p>	\$ _____ (2c)**
<p><i>**If (2c) exceeds \$15,000, the amount shall be adjusted with the following formula:</i></p>	
<p> $(\\$15,000 + 50\% \times (\text{amount over } \\$15,000))$ = \$ _____ *** </p>	

4.0 Drainage Certification Escrow

<p><i>***If (2c) equals or exceeds \$25,000, the Water Engineering and Field Services Manager shall have the ability to reduce the amount at their discretion.</i></p> <p>Greater of (2c) or \$3,000 =</p>	<p>\$ _____ (2)</p>
<p>4. Non-refundable administrative fee:</p>	<p>\$ 200 (3)</p>
<p>Total Escrow = (1) + (2) + (3) =</p>	<p>\$ _____</p>

This table is also available in spreadsheet format upon request.

4.3 Submittal and Review of the Drainage Certification Escrow

- 1) The Developer/owner or Design Engineer shall submit a formal request letter in writing requesting the Drainage Certification Escrow, the Engineer’s Cost Estimate, and the Drainage Certification Escrow calculation table to FCU.

The formal request letter shall include the following:

- A description of the status of the stormwater and drainage infrastructure construction at the site, including completed items and incomplete items. (Note that FCU will not allow for escrow to be applied to stormwater or drainage infrastructure that might otherwise pose a risk to health, safety, or welfare of building occupants if not installed prior to the release of CO, as determined in FCU’s discretion.)
 - A list of incomplete items and cost to construct or complete the items
 - Inclusion of Table 4.2.1-1 or Table 4.2.2-2 showing calculations
 - Professional Engineer stamp, signature, and date
- 2) The provided information will be reviewed within 10 business days for accuracy and completeness. FCU retains the right to make or require corrections to any submitted calculations or information.
 - 3) Once reviewed, FCU will contact the Developer/owner or Design Engineer to confirm acceptance and will then provide an escrow payment form to be filled out and submitted with the escrow payment in a format that is currently accepted by the City.

4.0 Drainage Certification Escrow

4.4 Guarantee

The Developer/owner shall guarantee (with the Drainage Certification Escrow as an assurance) that the stormwater facilities, and grading and drainage improvements, as shown on the approved plans are properly constructed and are free from defective materials and/or workmanship. The Developer/owner has 180 days to complete these improvements per the approved plans and certify their completion according to the Development Agreement.

Any acceptance of stormwater infrastructure or returning of the Drainage Certification Escrow shall not be construed to relieve the Developer/owner of the duty to maintain the stormwater infrastructure or as stipulated in the Development Agreement.

4.5 Return of the Drainage Certification Escrow

Once the grading and/or drainage improvements for the lot and/or building are constructed and a certification is submitted and approved by the FCU in accordance with the Development Plan Documents, the escrowed funds will be released to the Developer/owner. The escrow funds will be released within four weeks after a request to release these funds has been received by the FCU.

If all or portions of a Drainage Certification Escrow is not used by the City as described in Section 4.6 below and is otherwise incapable of being returned to the Developer/owner, the City retains the right to seek that all or portions of the Drainage Certification Escrow are or have been abandoned and forfeited, to seek rights to the Drainage Certification Escrow following any procedures required by law. See City Code Sections 23-131 through 23-138 (Intangible Personal Property).

Nothing herein shall be deemed to preclude the City from taking any other action with respect to the improvements and matters associated therewith.

4.5.1 Party the Drainage Certification Escrow Will Be Returned To

FCU shall return the Drainage Certification Escrow, or portions thereof, to the person or entity that paid the Drainage Certification Escrow unless and until a notarized assignment of the rights to the Drainage Certification Escrow is delivered to and approved by FCU identifying the new party that is entitled to all or portions of the Drainage Certification Escrow. It is thus the responsibility of the other parties to arrange for the transfer of rights to the Drainage Certification Escrow, or to replace certain Drainage Certification Escrow of one party with those of another.

In the event the Developer/owner sells the property or a lot within the property for which a Drainage Certification Escrow has been delivered to FCU, the determination of who should take ownership of the rights to the Drainage Certification Escrow shall be resolved entirely by the Developer/owner and the new

party; this shall not be the City's responsibility to calculate, evaluate, or phase a project and substitution of the Drainage Certification Escrow.

4.6 FCU Use of the Escrow

If the subject improvements are not completed within 180 days, the City will notify the Developer/owner in writing that the improvements must be completed and certified within 60 days of the notice date. If, at that time, completion and certification have not been performed, the escrowed funds will be forfeited and the City may use the funds to address the drainage and grading requirements of the property, including complete the improvements, perform the certification, and/or to complete that portion of the improvements possible with the available escrow balance. The City will notify the owner when these actions have been completed, their associated costs (which include administration costs to do the corrective work), and whether any surplus funds remain available for the owner to claim.

5.0 Close-Out Process

The Close-Out Process is set forth in this section and is required for all development sites. The Close-Out Process typically incorporates an Initial Close-Out Inspection and meeting and a Final Close-Out Inspection.

For small project sites where the drainage facilities are completely constructed and fully landscaped by the time a construction project is completed, the Initial Close-Out Inspection and Final Close-Out Inspection may be combined into a single inspection event. However, more commonly, construction sequencing on project sites involves the installation and completion of the drainage facilities first, followed by landscape installations and final stabilizations later. As such, the Final Close-Out Process has been split up into two distinct inspection phases to allow for Developers to more easily meet the requirements for receipt of their building Certificate of Occupancy (CO).

The purpose of the Initial Close-Out Inspection meeting is to verify that the final grades on the site and the stormwater infrastructure have been completely installed and meets the approved design so that the Developer can receive their building CO. This inspection should occur at or near the end of all construction activities. Landscape materials may be installed or partially installed at this stage and typically, final stabilization has not yet occurred. There may be some final detailing of the site grading and/or some smaller components of the stormwater infrastructure that are identified in this initial inspection that will need to be addressed by the contractor. As such, a punch list of these items will be formulated with the contractor that will need to be completed by the time of Final Close-Out Inspection.

The purpose of the Final Close-Out Inspection is to verify that the final grades on the site and the stormwater infrastructure have been completely installed per design and all remaining punch list items have been completely addressed. In addition, all landscaping and reseeding activities have been completed so that final stabilization has been achieved.

5.1 Initial Close-Out Inspection Process

- 1) Overall Site and Drainage Certification documentation has been submitted to the FCU for review, a minimum of two weeks in advance of the Initial Close-Out Inspection meeting.
- 2) A minimum of two weeks in advance, Developer shall schedule the Initial Close-Out Inspection meeting. Attendees at the meeting shall include:
 - a. FCU staff representatives from development review, erosion control/construction inspections, and post-construction inspections (3 representatives).
 - b. Current/future owner or Developer that is identified in the Development Agreement with the City.
 - c. Site contractor or general contractor that holds the construction contract with the Developer and who will be responsible for the warranty of the drainage system.
 - d. Current/future maintenance contractor (if known) that will be providing site stabilization and ensuring long-term maintenance of the site.
 - e. Design Engineer who provided the original design of the site and/or who provide the drainage certification documentation.
- 3) Prior to the Initial Close-Out Inspection meeting, the contractor shall clear all debris and sediment from the inspected areas. This includes the entire stormwater infrastructure (i.e. curb and gutter, swales, trickle channels, sediment traps, detention basins, pipes and inlets). Pertinent temporary BMPs shall be in good working condition and remain in place until the Final Close-Out inspection.
- 4) Initial Close-Out Inspection meeting will generally consist of the following:
 - a. Walking the site: conducting a group inspection of the stormwater facilities and final grades. This meeting should take place on a day when the entire site can be accessed, all site structures can be clearly viewed and there are no obstacles or snow pack that might limit the inspection process.
 - b. Review of the Standard Operating Procedures (SOPs): On-going and long-term SOPs, including site specific SOPs will be provided in the Development Agreement and a copy of that agreement will need to be brought to the meeting. Items typically discussed will include the location and maintenance of all onsite stormwater facilities such as inlets, outlets, detention basins and LID systems.

- c. Reviewing status of the vegetation establishment and long-term vegetation maintenance.
 - d. Post-construction inspection information handouts will be provided by the FCU to the owner. These handouts explain what the FCU looks for when inspecting detention basins, underground detention chambers and LID systems such as permeable pavers and rain gardens.
 - e. Share contact information: The property owner to provide owner entity name, contact phone number, mailing address, email and any other relevant contact information to the FCU for post-construction inspection coordination or correspondence as needed. The FCU to share pertinent contact information with the owner.
- 5) Prepare a punch list of any remaining items that the contractor is to address prior to the Final Close-Out Inspection. (If there are no punch list items and the only remaining item is complete establishment of the vegetation, then this initial meeting can count as the Final Close-Out Inspection and no further meetings would be required. The erosion escrow would be returned when vegetation is deemed established.

5.2 Final Close-Out Inspection Process

- 1) Overall Site and Drainage Certification documentation or updates to the originally submitted certification forms are to be submitted to the FCU for review, a minimum of two weeks in advance of the Final Close-Out Inspection. The FCU will approve the final drainage certifications if there are no outstanding items to address.
- 2) Owner submits soil amendment certifications and receipts to FCU, including those in the common areas or tracts. Soil Certifications for all areas will need to be accepted by FCU Erosion Control. Email address is erosion@fcgov.com.
- 3) Site vegetation is fully established (refer to Section 2.6 of this Chapter for final stabilization and established vegetation criteria).
- 4) The owner shall coordinate and schedule the Final Close-Out Inspection.
- 5) Prior to the Final Close-Out Inspection, the contractor shall clear all debris and sediment from the inspected areas. This includes all stormwater infrastructures (i.e. curb and gutter, swales, trickle channels, sediment traps, detention basins, pipes and inlets).

5.0 Close-Out Process

- 6) Final Close-Out Inspection will include follow-up field verification that all stormwater facilities, water quality and LID systems are in good working order and that revegetation measures have been completed.
- 7) Owner is to remove all remaining temporary BMP control measures from the site.
- 8) FCU is to return any remaining escrows.

DRAFT

Chapter 4: Construction Control Measures

Contents

- 1.0 Introduction 1
- 2.0 Scope of Applicability..... 1
 - 2.1 Exemptions to the Scope of Erosion Control Requirements 2
- 3.0 Erosion and Sediment Control 3
 - 3.1 Erosion 3
 - 3.2 Sedimentation..... 4
 - 3.3 Effective Erosion and Sediment Control 4
 - 3.4 Fundamental Erosion and Sediment Control Principles..... 5
- 4.0 Overview of Construction Control Measures 6
 - 4.1 Erosion Control Measures..... 9
 - 4.2 Sediment Control Measures 9
 - 4.3 Site Management..... 9
 - 4.4 Materials Management 10
 - 4.5 Proprietary Control Measures 10
- 5.0 Control Measure Selection and Planning..... 10
 - 5.1 Documenting Alternative Methods of Control 11
- 6.0 Detailed Construction Control Measures 13
 - 6.1 Erosion Control Detail/Fact Sheets 14
 - 6.2 Sediment Control Detail/Fact Sheets..... 15
 - 6.3 Site Management Control Detail/ Fact Sheets 15
 - 6.4 Materials Management Control Detail/Fact Sheets 16
- 7.0 Variances to Erosion Control Criteria..... 17
- 8.0 Standard Erosion Control Notes 17

1.0 Introduction

Effective management of stormwater runoff during Construction Activities is critical to the protection of water resources, including from potential pollutants sources. Both erosion and sediment controls are necessary for effective prevention from potential impacts caused by exposed dirt on a construction site. Also, site management and material management practices, are useful to prevent the potential pollution from other non-dirt sources.

This Chapter provides information on the City's erosion and sediment control program criteria. Appendices D and E are intended to provide supplemental information related to such criteria, and are referenced throughout this Chapter.

2.0 Scope of Applicability

All projects within the City's MS4 permitted area, and those City-owned municipal projects located outside of the City Limits shall always follow the criteria in this Manual. This includes but is not limited to, projects (public or private) seeking excavation permits, stockpile permits, development construction permits, and building permits.

Some lands in Fort Collins do not, however, fall under the City's MS4 Permit area. Federally-owned lands within Fort Collins are required to follow EPA Region 8 Criteria for erosion control and are not generally reviewed by the City unless requested by the federal government or as part of the National Environmental Policy Act process.

State of Colorado-owned lands within the Municipal boundary of the City of Fort Collins and that are accounted as part of another agency's State of Colorado MS4 Permit (e.g., CSU, Poudre School District, or Front Range Community College, CDOT) are also not required to follow the criteria in this Chapter and FCU will only ask for Erosion Control Materials for the areas within the City's MS4 Permit area. Thus, if the State of Colorado-owned land has no MS4 Permit where that entity has a construction project, a Site Plan Advisory Review (SPAR) is required and Erosion Control Materials are required to meet City criteria.

When a project spans past the City's MS4 permitted area, FCU will require a letter by the other MS4 jurisdiction with a clear description of which jurisdiction will be assuming responsibility for review and inspection of the various parts of the project.

Developers shall be responsible to ensure that appropriate and adequate Erosion Control Materials are produced to prevent the potential pollution from the sources associated with Construction Activities.

Developers shall be responsible to ensure that Erosion Control Materials and Manual are followed throughout the buildout to prevent all the potential pollution sources until the final stabilization of the project.

2.1 Exemptions to the Scope of Erosion Control Requirements

The requirements of this Chapter apply to all Construction Activities covered by this Manual, except for projects that do not require Erosion Control Materials, as set forth in Section 6.1.1 of Chapter 2 and restated here.

Some projects do not require Erosion Control Materials. Such projects are:

- Emergency work projects, where there is less than 43,560 ft² (1 acre) of Disturbed Area; or
- Projects with Construction Activities that:
 - 1) Have less than 10,000 ft² of Disturbed Area;
 - 2) Have shallower slopes than (4H:1V);
 - 3) Have no Sensitive Areas and are further than 50 feet away from any Sensitive Area; and
 - 4) Do not qualify for a CDPS General Permit Stormwater Discharges Associated with Construction Activity (typically as a result of a Larger Common Plan of Development or Sale).

With respect to such emergency work where there is less than 43,560 ft² (1 acre) of Disturbed Area, all other erosion control requirements must meet compliance, except to the extent that they cannot reasonably comply due to the emergency circumstances necessitating the emergency work. Emergency work will be allowed an accelerated review time.

Although no submittal of Erosion Control Material is required when an exemption to the scope applies, the site, project, or activity still must take preventative actions to keep pollution sources from being discharged into the drainage system in accordance with [City Code, Section 26-498](#), which still requires the area to apply control measures (such as, sweep, scrape, wet, collect, contain, dry, dispose, etc.) in order to prevent potential pollution sources (such as, dirt, saw cuttings, grinding operations, concrete wash water, concrete materials, trash, debris, landscape materials, and various other potential pollutants associated with construction) from entering the storm sewer system at all times. Projects that are exempt and received a complaint will be evaluated to determine if control measures outlined in this Chapter may be required of the project based upon site conditions observed during the complaint-based project inspection.

City policy provides that only those exclusions specifically listed in the MS4 permit may be allowed. Exceptions or variances to the requirements of the MS4 permit cannot and will not be granted.

3.0 Erosion and Sediment Control

3.1 Erosion

Although soil erosion is a natural process, accelerated soil erosion occurs on construction projects due to activities that disturb the natural soil and vegetation.

Erodibility of soils is affected by multiple factors including physical soil characteristics, soil qualities, and soil features, and rainfall characteristics.

Physical properties of soils such as particle size, cohesiveness, and density affect erodibility. Loose silt and sand-sized particles typically are more susceptible to erosion than "sticky" clay soils. Rocky soils are less susceptible to wind erosion, but are often found on steep slopes that are subject to water erosion.

Soil qualities are behavior and performance attributes that are not necessarily directly measured, but are inferred from observations of dynamic conditions and from soil properties. (i.e. soil qualities include natural drainage, infiltration, and frost action).

Soil features are attributes that are not directly part of the soil (i.e. soil features include slope steepness, slope lengths, vegetative cover slope and depth to restrictive layer). These features can greatly impact the use and management of the soil.

Soil qualities are most typically split into Hydrologic soil groups.

Hydrologic soil groups are based on estimates of runoff potential. Soils are assigned to one of four groups according to the rate of water infiltration when the soils are not protected by vegetation, are thoroughly wet, and receive precipitation from long-duration storms.

The soils in the United States are assigned to four groups (A, B, C, and D) and three dual classes (A/D, B/D, and C/D). The groups are defined as follows:

- Group A. Soils have a high infiltration rate (low runoff potential) when thoroughly wet. These consist mainly of deep, well drained to excessively drained sands or gravelly sands. These soils have a high rate of water transmission.
- Group B. Soils have a moderate infiltration rate when thoroughly wet. These consist chiefly of moderately deep or deep, moderately well drained or well drained soils that have moderately fine texture to moderately coarse texture. These soils have a moderate rate of water transmission.
- Group C. Soils have a slow infiltration rate when thoroughly wet. These consist chiefly of soils having a layer that impedes the downward movement of water or soils of moderately fine texture or fine texture. These soils have a slow rate of water transmission.

- Group D. Soils have a very slow infiltration rate (high runoff potential) when thoroughly wet. These consist chiefly of clays that have a high shrink-swell potential, soils that have a high water table, soils that have a clay pan or clay layer at or near the surface, and soils that are shallow over nearly impervious material. These soils have a very slow rate of water transmission.

A soil assigned to a dual hydrologic group (A/D, B/D, or C/D), the first letter is for the drained areas and the second is for the undrained areas. Only the soils that in their natural condition are in group D are assigned to dual classes.

Hydraulic soil properties and qualities for Fort Collins are typically based upon Larimer County Soil Survey from 1980 and are easily accessed in information published by the [USDA National Cooperative Soil Survey](#). This can be useful for further information around soil properties and qualities in the Fort Collins Area. Most of the soils in Colorado fall into the Group B and Group C soils and are susceptible to wind or water erosion, or both.

When surface vegetative cover and soil structure are disturbed during construction, the soil is more susceptible to erosion. Vegetation plays a critical role in controlling erosion. Roots bind soil together and the leaves or blades of grass reduce raindrop impact forces on the soil. Grass, tree litter, and other ground cover not only intercept precipitation and allow infiltration, but also reduce runoff velocity and shear stress at the surface. Vegetation reduces wind velocity at the ground surface, and provides a rougher surface that can trap particles moving along the ground. Once vegetation is removed, soils become more susceptible to erosion.

3.2 Sedimentation

Sedimentation occurs when eroded soil transported in wind or water is deposited from its suspended state. During a typical rainstorm in Colorado, runoff normally builds up rapidly to a peak and then diminishes. Because the amount of sediment a watercourse can carry is dependent upon the velocity and volume of runoff, sediment is eventually deposited as runoff decreases. The deposited sediments may be re-suspended when future runoff events occur. In this way, sediments are moved progressively downstream in the waterway system.

3.3 Effective Erosion and Sediment Control

It is better to minimize erosion than to rely solely on Sediment Control Measures to remove sedimentation from construction runoff. Erosion Control Measures limit the amount and rate of erosion occurring on disturbed areas. Sediment Control Measures attempt to capture the soil that has been eroded before it leaves the project. Despite the use of both erosion control and sediment control measures, some amount of sediment will remain in runoff leaving a project, but the use of a "treatment train" of practices can help to minimize offsite transport of sediment. The last line of treatment such as inlet protection, and sediment control in basins, should be viewed as a "polishing" control measure, as opposed to the only treatment on the project.

Section 6.0 of this Chapter provides an overview of Erosion and Sediment Control Measures. Appendix E includes detailed Construction Control Measures that provides design details and guidance for effective use of various erosion and sediment control practices. Control measures should be combined and selected to meet these objectives:

- Conduct land-disturbing activities in a manner that effectively reduces accelerated soil erosion and reduces sediment movement and deposition offsite.
- Schedule construction activities to minimize the total amount of soil exposed at any given time.
- Establish temporary or permanent cover on areas that have been disturbed as soon as practical after grading is completed.
- Design and construct temporary or permanent facilities to limit the flow of water to non-erosive velocities for the conveyance of water around, through, or from the disturbed area.
- Remove sediment caused by accelerated soil erosion from surface runoff water before it leaves the project.
- Stabilize disturbed areas with permanent vegetative cover and provide permanent stormwater quality control measures for the post-construction condition.

3.4 Fundamental Erosion and Sediment Control Principles

The intent of erosion and sediment control design is to protect adjacent properties and downstream properties from the detrimental effects of Construction Activity. Water erosion is always directional, i.e., always down-slope. This directional nature of water erosion can be used to design resistance to sediment movement near the downstream edge of the disturbed property. The erosion control design may govern slope placement so that sediment-laden runoff is not directly tributary to an adjacent property. The slope may need to be built to accommodate a temporary diversion channel, which keeps water on the disturbed parcel.

Control measures are necessary for each phase of development and it is understood that initial grading and construction will require certain control measures, which will change or be replaced as development progresses. Temporary control measures such as silt fences or diversion structures may be used during the initial grading and other applicable construction sequences, and later either removed completely, or replaced with grass, water quality structure, LID, or other permanent erosion or sediment control.

Control measures can be arranged to perform in series or a “treatment train” so that sediment reduction caused by one measure releases less sediment to the next. In this manner, series resistances to

sediment movement are built into a project so that stormwater release to adjacent properties or streams are carrying minimal Sediment. The “treatment train” can be designed to minimize costs, and to minimize interference with onsite Construction Activities.

The construction and maintenance of Erosion Control Measures is critical to ensure proper performance. Erosion Control Plans must include construction details and maintenance guidelines.

4.0 Overview of Construction Control Measures

The use of control measures can be structural and non-structural in how they are applied, as well as, temporary (primary focus of this Chapter) and permanent measures (other permanent design structures water quality devices and LIDs covered in other Chapters of this Manual) with regards to how long they are designed to function as a control measure. All control measures should be effective in preventing or reducing sediment, or other potential pollutants, transportation from the project to the maximum extent practicable.

Construction Control Measures include not only Erosion and Sediment Control Measures, but also material management and site management control measures. Each control measure varies with regard to the functions they provide and where they are best applied. **Table 4.0** provides a qualitative characterization of the roles that various BMPs provide with regard to serving erosion control functions, sediment control functions, or site/materials management roles. In particular, it is important to understand whether the primary role of the control measure is to control erosion, sediment, material management or site management.

Figure 4.0. Components of Effective Stormwater Management on Projects

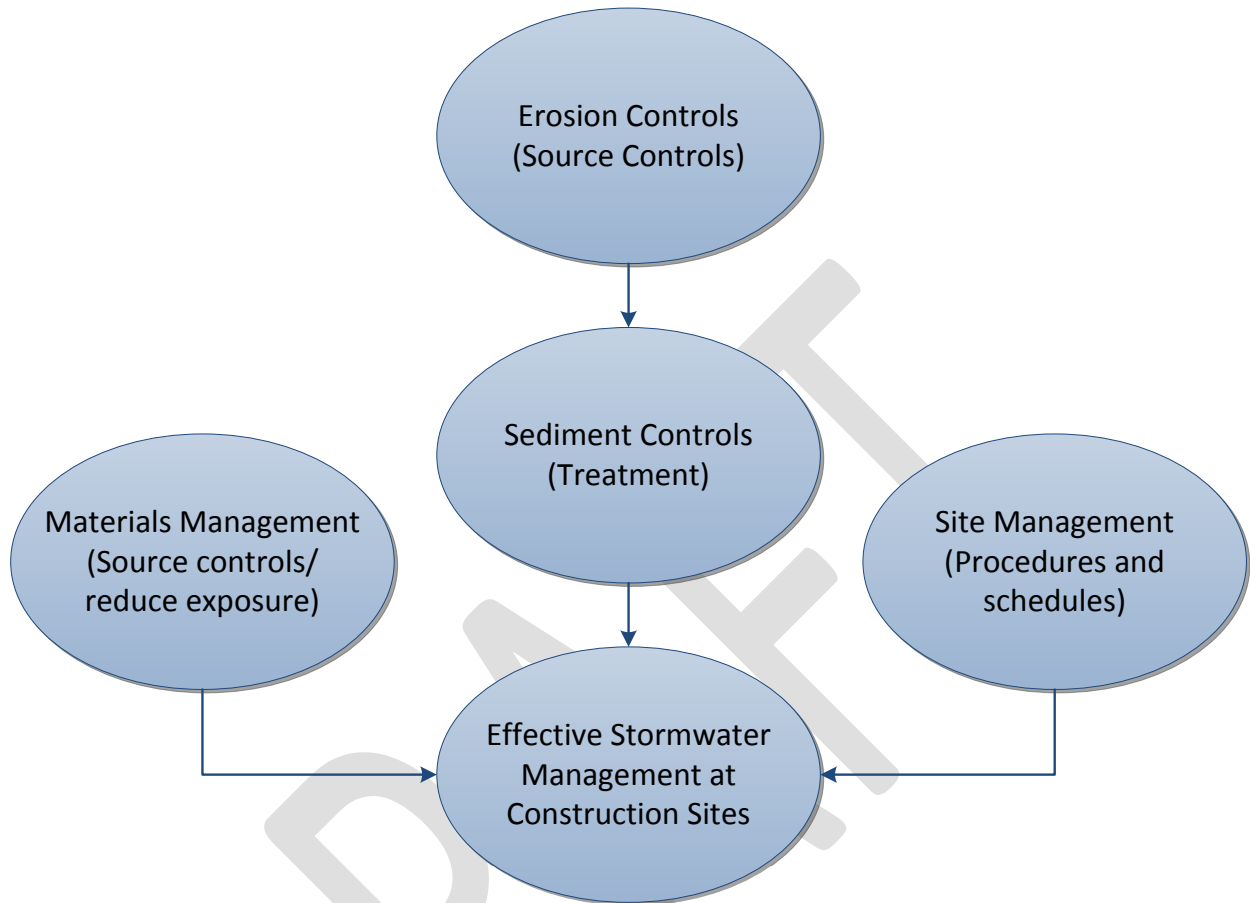

A key to effective stormwater management at a construction site is to understand how construction stormwater management requirements change over the course of a construction project and how to install and remove the right control measures as the project progresses in a way that reduces and eliminates potential pollutant transportation from the construction site to the maximum extent practicable.

The control measures identified in the subsequent four sections (Section 4.1 through section 4.4 of this Chapter) are provided in an in-depth fact sheet in Appendix E. These control measure detail sheets give local City requirements and guidance on applicability, design, installation, maintenance, and final disposition.

Table 4.0. Overview of Construction BMPs

Construction Control Measures			
Functions	Erosion Control	Sediment Control	Site/Material Management
Brush Barrier	Moderate	Moderate	No
Check Dams	Yes	Moderate	No
Chemical Treatment	Moderate	Yes	No
Compost Blankets and Filter Berms	Yes	Moderate	No
Concrete Washout Area	No	No	Yes
Construction Fence	No	No	Yes
Construction Phasing	Moderate	Moderate	Yes
Dewatering Operations	Moderate	Yes	Yes
Earth Dikes/Drainage Swales	Yes	Moderate	No
Good Housekeeping (Multiple Practices)	No	No	Yes
Inlet Protection (Various Forms)	No	Yes	No
Mulching	Yes	Moderate	No
Paving and Grinding Operations	No	No	Yes
Protection of Existing Vegetation	Yes	Moderate	Yes
Rock Sock (Perimeter Control)	No	Yes	No
Rolled Erosion Control Products	Yes	No	No
Rough Cut Street Control	Yes	Moderate	No
Sediment Basin	No	Yes	No
Sediment Control Log	Moderate	Yes	No
Sediment Traps	No	Yes	No
Silt Fence	No	Yes	No
Soil Binders	Yes	No	Moderate
Stabilized Construction Roadway	Yes	Moderate	Yes
Stabilized Staging Area	Yes	Moderate	Yes
Stockpile Management	Yes	Yes	Yes
Streambank Stabilization	Yes	No	No
Street Sweeping / Vacuuming	No	Yes	Yes
Surface Roughening	Yes	No	No
Temporary Batch Plant	No	No	Yes
Temporary Diversion Channel	Yes	No	No
Temporary Outlet Protection	Yes	Moderate	No
Temporary Slope Drains	Yes	No	No
Temporary Stream Crossing	Yes	Yes	No
Temporary/Permanent Seeding	Yes	No	No
Terracing	Yes	Moderate	No
Vegetative Buffers	Moderate	Yes	Yes
Vehicle Tracking Control	Moderate	Yes	Yes
Wind Erosion /Dust Control	Yes	No	Moderate

4.1 Erosion Control Measures

Erosion Control Measures are source controls used to limit erosion of soil. These are typically surface treatments that stabilize soil that has been exposed by excavation or grading, although some limit Erosion by redirecting flows or reducing velocities of concentrated flow.

Reference: [Fact sheets for erosion control practices are provided in Section 6.1 of this Chapter.](#)

4.2 Sediment Control Measures

Sediment Control Measures limit transport of sediment offsite to downstream properties and receiving waters. Sediment controls are the second line of defense, capturing soil that has been eroded. Sediment controls generally rely on treatment processes that either provide filtration through a permeable media or that slow runoff to allow the settling of suspended particles. A third treatment process that is used in some parts of the country includes advanced treatment systems employing chemical addition (flocculent) to promote coagulation and settling of sediment particles.

The City does not permit the use of chemical treatment with Construction Activities.

Reference: [Fact sheets for sediment control practices are provided in Section 6.2 of this Chapter.](#)

4.3 Site Management

Site management is often ultimately the deciding factor in how effective control measures are on a project. Control measures implemented at the project must not only be properly selected and installed, but also must be inspected, maintained, and properly repaired for the duration of the construction project. In addition to general site management, there are a number of specific site management practices that affect construction site management. For example, effective construction scheduling (phasing and sequencing) helps minimize the duration of exposed soils. Protection of existing vegetation also minimizes exposed areas and can reduce the cost of final project stabilization. Stabilized construction entrances (vehicle tracking controls) and street sweeping are critical source control measures to minimize the amount of sediment that leaves a project. Additionally, there are several miscellaneous activities that must be carefully conducted to protect water quality such as dewatering operations, temporary batch plants, temporary stream crossings and other practices.

As part of the construction kick-off meeting for the project (or for major sequences of construction), an effective strategy is to include a training component related to construction site stormwater management. Such training should provide basic education to site personnel regarding the requirements of the state and local construction stormwater permits and programs and bring awareness to the serious

finest and penalties that can result from failure to comply with permit requirements. The individual or individuals responsible for inspection and maintenance of construction control measures should have a practical understanding of how to maintain construction control measures proactively in effective operating condition and how to identify conditions where failure is eminent or has already occurred. In addition to project-specific training, several training courses are available across the state regarding construction site stormwater management.

[Reference:](#) Fact sheets for site management practices are provided in Section 6.3 of this Chapter.

4.4 Materials Management

Materials management control measures are source control practices intended to limit contact of runoff with potential pollutant sources commonly found at construction sites such as construction materials and equipment-related fluids. By intentionally controlling and managing areas where chemicals are handled, the likelihood of these materials being transported to waterways is reduced.

[Reference:](#) Fact sheets for materials management practices are provided in Section 6.4 of this Chapter.

4.5 Proprietary Control Measures

Many proprietary control measures are available for construction site stormwater management. This Manual does not provide a list of approved products; however, the City requires that a proprietary product have a control measure fact sheet/detail sheet that must be provided to the City. The fact sheet must address all items that the City may require before accepting a proprietary control measure.

[Reference:](#) All written submissions shall adhere to the requirements of Section 5.1 of this Chapter, as well as follow the variance procedure provided in Section 8.0 of Chapter 2.

5.0 Control Measure Selection and Planning

All projects that are required to supply Erosion Control Materials shall plan and select the materials before the installation of control measures to minimize potential pollutant sources from initial disturbance of a project, until final stabilization and throughout every phase of construction to the maximum extent practicable.

Construction Control Measures shall be selected, designed, installed, maintained, and removed based upon project-specific conditions and in accordance with good engineering, hydrologic, and potential pollutant source control practices.

Control measures shall be selected based on the physical layout and project conditions that will exist during each phase and during each phase (sequence) of construction, because project conditions change through the various stages of construction so too shall the control measures need to change. This is to include individual lot protection on residential developments along with entire block protection on apartment complex once the pavement has been installed.

The Erosion Control Material shall be consistent with other plans (grading, plat, landscaping, etc.) as those plans may change with various updates, comments, and revisions. The Erosion Control Materials should be reevaluated with every set of plan revisions to make sure all plans are compatible.

Effective construction stormwater management may also require contractual mechanisms to ensure that any sub-contractors will be taking the correct steps to prevent erosion, sediment and non-dirt related pollutant source discharges from the project.

Projects that include construction work in waterways, along linear projects, with underground trenching, with native seed and in areas with habitat, all have some unique cases that shall be evaluated based upon their unique conditions and the nature of their Construction Activities.

Detailed Construction Control Measure fact sheets are provided in Appendix E and contain information on each control measures applicability, installation, maintenance and design details.

The fact sheets are intended to be stand-alone documents that can be used for reference or inserted directly into submitted Erosion Control Materials.

[Reference:](#) For further clarification, refer to Section 7.0 of Appendix D.

5.1 Documenting Alternative Methods of Control

Any non-standard control, or alternative control measure shall be submitted for review together with a detail of the proposed measure. Non-standard control measure proposals will be required to be processed through the Variance Request Process (as outlined in Section 8.0 of Chapter 2) before the measure will be allowed to be used on the project. In addition, non-standard or alternative control measures must adhere to the Erosion Control Criteria based upon the functionality and effectiveness in accordance with sound engineering and hydrological practices. Likewise, during construction, any substitution of a standard control measure for a non-standard or job-specific control measure shall also require it to be submitted and accepted prior to use in the field. The determination of whether a control measure is standard or not shall be made by FCU in its sole discretion.

In addition to the requirements provided in Section 8.0 of Chapter 2, all written submissions for a variance of control measures shall address all applicable questions that follow:

General

- Does the product provide equivalent or better function than the design details specified in this Manual?
- What are the installation procedures?
- What are the maintenance requirements? Is special equipment required for maintenance?
- What are the consequences of failure of the product?
- Has the product been successfully implemented on other projects in the metropolitan Denver or northern Colorado area? If so, where and who was the inspecting authority?

Inlet Protection

- Does the inlet protection enable runoff to enter the inlet without excessive ponding in traffic areas?
- How does the control measure provide for overflow due to large storm events or blockages?
- How is the control measure secured to the street or curb? Will it result in damage to concrete or pavement? Is it secured in a manner that prevents short-circuiting or collapsing into the inlet?
- Does the control measure appear to be sturdy enough to withstand typical activities conducted at construction sites or traffic on public roadways?
- Is there potential for pollutant leaching from the BMP?
- For inlet inserts, is special equipment required to remove the insert? Is the insert material strong enough to withstand tearing and/or collapse into the inlet, even when maintenance is less than ideal?

Perimeter Controls

- How is the perimeter control installed (e.g., trenching, staking)? Perimeter controls that are not adequately secured may be subject to undercutting and washout.
- Is the material used in the perimeter control adequately durable for the life of the construction project?

- How are vehicle tracking and project access controlled where flexible perimeter controls allow vehicles to drive over the control measure?

Hydraulically Applied Products

- Does the product contain chemicals, pollutants, nutrients, or other materials that could adversely impact receiving waters or groundwater?
- Has the product been adequately field tested under local conditions to ensure that the service life is consistent with the manufacturer's representation?
- Does use of the product require special permits?

All submissions shall be evaluated internally by staff to interpret the engineering principles and if the proposed Construction Control Measure adheres to water quality regulations required by the City, State, and Federal governing bodies.

The review and determination of the variance request under this Section 5.1 by the Utilities Executive Director under Section 8.0 of Chapter 2 may consider, among other things, whether the proposed Construction Control Measure is realistic, reasonable, in accordance with good engineering and hydrological practices, and not a potential impact on discharging to the river.

Any acceptance of the use of a control measure does not hold the City liable for any damages associated with this proprietary protect and will be a “use at own risk” by the Developer.

6.0 Detailed Construction Control Measures

All control measures when selected to be used on a project shall be installed, implemented, and maintained, in accordance with the following control measure details in this section.

All the following details shall, per the City MS4 Permit requirements, prevent potential pollution sources from impacting state waters. Control measures shall also be appropriate for the specific Construction Activity, the applicable potential pollutant sources, and phase of construction. See Appendix D, Section 7.0 for help in the selection of control measures.

6.1 Erosion Control Detail/Fact Sheets

The details provided in the UDFCD Manual, dated 2010, are to be utilized in the preparation of the Erosion Control Materials. A copy of all control measure fact sheets can be found in Appendix E.

- EC- 1 Surface Roughening (SR)
- EC-2 Temporary and Permanent Seeding (TS/PS)
- EC-3 Soil Binders (SB)
- EC-4 Mulching (MU)
- EC-5 Compost Blanket and Filter Berm (CB)
- EC-6 Rolled Erosion Control Products (RECP)
(Includes Erosion Control blankets [ECBs] and turf reinforcement mats [TRMs])
- EC-7 Temporary Slope Drains (TSD)
- EC-8 Temporary Outlet Protection (TOP)
- EC-9 Rough Cut Street Control (RCS)
- EC-10 Earth Dikes and Drainage Swales (ED/DS)
- EC-11 Terracing (TER)
- EC-12 Check Dams (CD) (also includes Reinforced Check Dams [RCD])
- EC-13 Streambank Stabilization (SS)
- EC-14 Wind Erosion / Dust Control (DC)

6.2 Sediment Control Detail/Fact Sheets

The details provided in the UDFCD Manual, dated 2010, are to be utilized in the preparation of the Erosion Control Materials. A copy of all control measure fact sheets can be found in Appendix E.

- SC-1 Silt Fence (SF)
- SC-2 Sediment Control Log (SCL)
- SC-3 is not a part of this Manual*
- SC-4 Brush Barrier (BB)
- SC-5 Rock Sock (RS)
- SC-6 Inlet Protection (IP) (multiple types)
- SC-7 Sediment Basin (SB)
- SC-8 Sediment Trap (ST)
- SC-9 Vegetated Buffers (VB) **
- SC-10 Chemical Treatment (CT) (also known as Advanced Treatment Systems [ATS])

*The SC-3 Straw Bale Barriers fact sheet for is not included as these are prohibited from use as a sediment control measure in the City.

**Buffer strips of natural vegetation may be utilized as a control measure with one additional supportive control measure in alignment with state guidance documents that have been published for the use of vegetative buffers.

6.3 Site Management Control Detail/ Fact Sheets

The details provided in the UDFCD Manual, dated 2010, are to be utilized in the preparation of the Erosion Control Materials. A copy of all control measure fact sheets can be found in Appendix E.

- SM-1 Construction Phasing/Sequencing (CP)
- SM-2 Protection of Existing Vegetation (PV)
- SM-3 Construction Fence (CF)*

- SM-4 Vehicle Tracking Control (VTC) (multiple types)
- SM-5 Stabilized Construction Roadway (SCR)
- SM-6 Stabilized Staging Area (SSA)
- SM-7 Street Sweeping and Vacuuming (SS)
- SM-8 Temporary Diversion Channel (TDC)
- SM-9 Dewatering Operations (DW)
- SM-10 Temporary Stream Crossing (TSC) (multiple types)
- SM-11 Temporary Batch Plant (TBP)
- SM-12 Paving and Grinding Operations (PGO)

*Adequate protection of both tree limbs and root systems is important when specifying limits of Construction Activity. Use construction fence or other barriers to protect areas that should not be compacted or disturbed.

6.4 Materials Management Control Detail/Fact Sheets

The details provided in the UDFCD Manual, dated 2010, are to be utilized in the preparation of the Erosion Control Materials. A copy of all control measure fact sheets can be found in Appendix E.

- MM-1 Concrete Washout Area (CWA)
- MM-2 Stockpile Management (SP)
- MM-3 Good Housekeeping Practices (GH) (including Spill Prevention and Control, Material Use, Material Delivery and Storage, Solid Waste Management, Hazardous Waste Management, Sanitary/Septic Waste Management, and Vehicle & Equipment Fueling, Maintenance and Cleaning)

7.0 Variances to Erosion Control Criteria

Questions related to the criteria set forth in this Chapter may be made to FCU staff, who will work with the requesting party to address any questions and concerns. Developers may also request a variance from the erosion control requirements set forth in this Manual pursuant to Section 5.1 of this Chapter and Section 8.0 of Chapter 2.

[Reference: Variance Request Process can be found in Section 8.0 of Chapter 2: Development Submittal Requirements.](#)

8.0 Standard Erosion Control Notes

The “Standard Erosion Control Notes” shall be included in each Erosion Control Plan. These notes shall not be amended as to ensure the consistent application of the standard.

[Reference: The standard Erosion Control Notes can be found in Appendix F of this Manual.](#)

A copy of the Standard Notes are also available on the City’s Erosion Control webpage www.fcgov.com/erosion.

Chapter 5: Hydrology Standards

Contents

- 1.0 Overview 1
 - 1.1 Storm Runoff Determination 1
 - 1.2 Design Storm Frequencies 1
 - 1.3 Water Quality Storm Provisions..... 2
 - 1.4 Design Storm Return Periods 2
 - 1.4.1 Minor Storm (2-Year) Provisions..... 2
 - 1.4.2 Major Storm (100-Year) Provisions..... 2
- 2.0 Runoff Methodologies 3
- 3.0 Rational Method 3
 - 3.1 Rational Formula..... 3
 - 3.2 Runoff Coefficients..... 4
 - 3.2.1 Composite Runoff Coefficients 5
 - 3.2.2 Runoff Coefficient Frequency Adjustment Factor 5
 - 3.3 Time of Concentration 6
 - 3.3.1 Overall Equation..... 6
 - 3.3.2 Overland Flow Time 6
 - 3.3.3 Channelized Flow Time 7
 - 3.3.4 Total Time of Concentration 7
 - 3.4 Intensity-Duration-Frequency Curves for Rational Method 7
- 4.0 SWMM 10
 - 4.1 Input Parameters 10
 - 4.1.1 Intensity-Duration-Frequency Curves for SWMM 12
 - 4.1.2 Conveyance Element Methodology..... 13
 - 4.1.3 Basin Width 13
 - 4.2 Flow Analysis..... 13

1.0 Overview

This Chapter presents information that is specific to the City of Fort Collins and may be a significant deviation from the information presented in the UDFCD Manuals. Utilizing UDFCD methodologies for hydrology calculations may not be accepted by FCU.

1.1 Storm Runoff Determination

The runoff analysis for a development must be based on the proposed land use for that area. Contributing runoff from upstream areas must be based on the existing land use and the topographic characteristics of those areas.

All runoff calculations, requirements and assumptions must be based on the Master Drainage Plan for the area that is being developed.

Natural topographic features are the basis of location for drainage easements and future runoff calculations. Average land slopes may be utilized in runoff computations unless better data is available. The drainage facilities designed must be able to handle the design flows with minimal erosion damage to the system.

1.2 Design Storm Frequencies

All drainage system design and construction must take into consideration three separate and distinct drainage problems. The first is the eightieth (80th) percentile storm event or the rain event for which 80% of all rain events have an equal or smaller depth of rain. This storm event is often referred to as the “water quality storm” and is used to design water quality components of storm drainage systems.

The second is the “minor storm” or “initial storm”, which is the 2-year storm in the City of Fort Collins. This is the storm that has a probability of occurring, on the average, once every two (2) years, or one that has a fifty percent (50%) probability of exceedance every year.

The third is the “major storm”, which is the 100-year storm in the City of Fort Collins. This is the storm that has a probability of occurring, on the average, once every one hundred (100) years, or one that has a one percent (1%) probability of exceedance every year.

RUNOFF CALCULATIONS

BOTH THE 2-YEAR AND THE 100-YEAR STORM EVENTS MUST BE INCLUDED IN ALL DRAINAGE SYSTEM ANALYSES AND REPORTS

1.3 Water Quality Storm Provisions

Water quality drainage system, as a minimum, must be designed to address initial water quality considerations. The water quality storm shall be used in calculating the water quality capture volume (WQCV) for standard water quality and volume-based Low Impact Development (LID) systems. These are discussed in more detail in Chapter 5: Detention, and in Appendix C: LID Implementation Manual.

1.4 Design Storm Return Periods

The 100-year drainage system, as a minimum, must be designed to convey stormwater runoff from the 100-year recurrence flood to minimize life hazards and health, damage to structures, and interruption to traffic and services. Runoff from the 100-year storm can be conveyed in the urban street system, channels, storm sewers and other facilities, provided the conveyance is done within acceptable criteria as specified in this Manual.

All new public and private improvements must plan, design, and construct drainage systems that account for the 2-year storm event as well as the 100-year storm. The 100-year storm event is the standard level of protection in the City of Fort Collins unless otherwise specified by the applicable Master Drainage Plan. Storms with recurrence intervals greater than 100-year, may still need to be considered in the drainage analysis, if only on a qualitative basis.

1.4.1 Minor Storm (2-Year) Provisions

The 2-year drainage system, as a minimum, must be designed to transport stormwater runoff from the 2-year recurrence interval storm event with minimal disruption to the urban environment. The 2-year storm runoff can be conveyed in the curb and gutter area of the street or roadside ditch (subject to street classification and capacity), by a storm sewer, a channel, or other conveyance facility. See Chapter 8: Streets, Inlets and Conveyance for more detail.

The design objectives for the minor storm drainage system are to minimize inconvenience, to protect against recurring minor damage and to reduce maintenance costs in order to create an orderly drainage system at a reasonable cost. The 2-year storm drainage system may include such facilities as curb and gutter, storm sewer, open channels, drainage ways, ponds, rivers, streams and detention facilities.

1.4.2 Major Storm (100-Year) Provisions

The design objectives of the 100-year storm drainage system are to eliminate loss of life and prevent and/or minimize property damage. Major drainage systems may include storm sewers, curb, gutter and streets, open channels, drainage ways, ponds, rivers, streams and detention facilities. A comprehensive storm drainage system must incorporate the design objectives for both the minor and major storms.

2.0 Runoff Methodologies

There are two runoff analysis methodologies that are approved by the City: the Rational Method and the Stormwater Management Model (SWMM). In general, the chosen methodology should follow the basin size limitations listed in **Table 2.0-1** below. SWMM must also be used to assess the performance of multiple detention basins in parallel or in series in a particular watershed. The City is the determining authority with respect to the appropriate methodology to use under uncertain circumstances. Please note that the Colorado Urban Hydrograph Procedure (CUHP) is not allowed to be utilized for hydrology analysis for Fort Collins area projects because this procedure is calibrated using Denver/Boulder rainfall data.

Table 2.0-1: Runoff Calculation Method

Project Size	Runoff Calculation Method
< 5 acres	Rational Method Required
5-20 acres	Rational Method or SWMM Accepted
≥ 20 acres	SWMM Required

[Reference: Drainage Report submittal requirements must be prepared in accordance with the criteria set forth in Chapter 2: Development Submittal Requirements.](#)

3.0 Rational Method

3.1 Rational Formula

The methodology and theory behind the Rational Method is not covered in this Manual as this subject is well described in many hydrology reference books. However, the Rational Method procedure is generally provided in the following sections. Runoff coefficient calculations, rainfall data, and the time of concentration formula are specific to the City and are included below.

The Rational Formula is represented by the following equation:

$$Q = CIA$$

Equation 5-1

Where: Q = Peak Rate of Runoff, cfs

C = Runoff Coefficient, dimensionless

I = Rainfall Intensity, in/hr

A = Area of the Basin or Sub-basin, acres

3.2 Runoff Coefficients

Runoff coefficients used for the Rational Method are determined based on either overall land use or surface type across the drainage area. For Overall Drainage Plan (ODP) submittals, when surface types may not yet be known, land use shall be used to estimate flow rates and volumes. **Table 3.2-1** lists the runoff coefficients for common types of land uses in the City.

Table 3.2-1. Zoning Classification - Runoff Coefficients

Land Use	Runoff Coefficient (C)
Residential	
Urban Estate	0.30
Low Density	0.55
Medium Density	0.65
High Density	0.85
Commercial	
Commercial	0.85
Industrial	0.95
Undeveloped	
Open Lands, Transition	0.20
Greenbelts, Agriculture	0.20

Reference: For further guidance regarding zoning classifications, refer to the Land Use Code, Article 4.

For a Project Development Plan (PDP) or Final Plan (FP) submittals, runoff coefficients must be based on the proposed land surface types. Since the actual runoff coefficients may be different from those specified in **Table 3.2-1**, **Table 3.2-2** lists coefficients for the specific types of land surfaces.

Table 3.2-2. Surface Type - Runoff Coefficients

Surface Type	Runoff Coefficients
Hardscape or Hard Surface	
Asphalt, Concrete	0.95
Rooftop	0.95
Recycled Asphalt	0.80
Gravel	0.50
Pavers	0.50
Landscape or Pervious Surface	
Lawns, Sandy Soil, Flat Slope < 2%	0.10
Lawns, Sandy Soil, Avg Slope 2-7%	0.15
Lawns, Sandy Soil, Steep Slope >7%	0.20
Lawns, Clayey Soil, Flat Slope < 2%	0.20
Lawns, Clayey Soil, Avg Slope 2-7%	0.25
Lawns, Clayey Soil, Steep Slope >7%	0.35

3.2.1 Composite Runoff Coefficients

Drainage sub-basins are frequently composed of land that has multiple surface types or zoning classifications. In such cases a composite runoff coefficient must be calculated for any given drainage sub-basin.

The composite runoff coefficient is obtained using the following formula:

$$C = \frac{\sum_{i=1}^n (C_i \times A_i)}{A_t}$$

Equation 5-2

Where: C = Composite Runoff Coefficient

C_i = Runoff Coefficient for Specific Area (A_i), dimensionless

A_i = Area of Surface with Runoff Coefficient of C_i, acres or square feet

n = Number of different surfaces to be considered

A_t = Total Area over which C is applicable, acres or square feet

3.2.2 Runoff Coefficient Frequency Adjustment Factor

The runoff coefficients provided in **Table 3.2-1** and **Table 3.2-2** are appropriate for use with the 2-year storm event. For any analysis of storms with higher intensities, an adjustment of the runoff coefficient is required due to the lessening amount of infiltration, depression retention, evapotranspiration and other losses that have a proportionally smaller effect on high-intensity storm runoff. This adjustment is

applied to the composite runoff coefficient. These frequency adjustment factors, C_f , are found in **Table 3.2-3**.

Table 3.2-3. Frequency Adjustment Factors

Storm Return Period (years)	Frequency Adjustment Factor (C_f)
2, 5, 10	1.00
25	1.10
50	1.20
100	1.25

$C \times C_f$
 PRODUCT OF $C \times C_f$
 CANNOT EXCEED THE
 VALUE OF 1

3.3 Time of Concentration

3.3.1 Overall Equation

The next step to approximate runoff using the Rational Method is to estimate the Time of Concentration, T_c , or the time for water to flow from the most remote part of the drainage sub-basin to the design point under consideration.

The Time of Concentration is represented by the following equation:

$$T_c = T_i + T_t \tag{Equation 5-3}$$

Where: T_c = Total Time of Concentration, minutes

T_i = Initial or Overland Flow Time of Concentration, minutes

T_t = Channelized Flow in Swale, Gutter or Pipe, minutes

3.3.2 Overland Flow Time

Overland flow, T_i , can be determined by the following equation:

$$T_i = \frac{1.87(1.1 - C \times C_f)\sqrt{L}}{\sqrt[3]{S}} \tag{Equation 3.3-2}$$

Where: C = Runoff Coefficient, dimensionless

C_f = Frequency Adjustment Factor, dimensionless

L = Length of Overland Flow, feet

S = Slope, percent

OVERLAND FLOW LENGTH
 L=200' MAX IN DEVELOPED AREAS
 L=500' MAX IN UNDEVELOPED AREAS

3.3.3 Channelized Flow Time

Travel time in a swale, gutter or storm pipe is considered “channelized” or “concentrated” flow and can be estimated using the Manning’s Equation:

$$V = \frac{1.49}{n} R^{2/3} S^{1/2} \quad \text{Equation 5-4}$$

Where: V = Velocity, feet/second

n = Roughness Coefficient, dimensionless

R = Hydraulic Radius, feet (Hydraulic Radius = area / wetted perimeter, feet)

S = Longitudinal Slope, feet/feet

And:

$$T_t = \frac{L}{V \times 60} \quad \text{Equation 5-5}$$

3.3.4 Total Time of Concentration

A minimum T_c of 5 minutes is required. The maximum T_c allowed for the most upstream design point shall be calculated using the following equation:

$$T_c = \frac{L}{180} + 10 \quad \text{Equation 3.3-5}$$

The Total Time of Concentration, T_c , is the lesser of the values of T_c calculated using $T_c = T_i + T_t$ or the equation listed above.

T_c

- A MINIMUM T_c OF 5 MINUTES IS REQUIRED IN ALL CASES.
- A MAXIMUM T_c OF 5 MINUTES IS TYPICAL FOR SMALLER, URBAN PROJECTS.

3.4 Intensity-Duration-Frequency Curves for Rational Method

The two-hour rainfall Intensity-Duration-Frequency curves for use with the Rational Method is provided in **Table 3.4-1** and **Figure 3.4-1**.

Table 3.4-1. IDF Table for Rational Method

Duration (min)	Intensity 2-year (in/hr)	Intensity 10-year (in/hr)	Intensity 100-year (in/hr)
5	2.85	4.87	9.95
6	2.67	4.56	9.31
7	2.52	4.31	8.80
8	2.40	4.10	8.38
9	2.30	3.93	8.03
10	2.21	3.78	7.72
11	2.13	3.63	7.42
12	2.05	3.50	7.16
13	1.98	3.39	6.92
14	1.92	3.29	6.71
15	1.87	3.19	6.52
16	1.81	3.08	6.30
17	1.75	2.99	6.10
18	1.70	2.90	5.92
19	1.65	2.82	5.75
20	1.61	2.74	5.60
21	1.56	2.67	5.46
22	1.53	2.61	5.32
23	1.49	2.55	5.20
24	1.46	2.49	5.09
25	1.43	2.44	4.98
26	1.4	2.39	4.87
27	1.37	2.34	4.78
28	1.34	2.29	4.69
29	1.32	2.25	4.60
30	1.30	2.21	4.52
31	1.27	2.16	4.42
32	1.24	2.12	4.33
33	1.22	2.08	4.24
34	1.19	2.04	4.16
35	1.17	2.00	4.08
36	1.15	1.96	4.01
37	1.16	1.93	3.93
38	1.11	1.89	3.87

Duration (min)	Intensity 2-year (in/hr)	Intensity 10-year (in/hr)	Intensity 100-year (in/hr)
39	1.09	1.86	3.8
40	1.07	1.83	3.74
41	1.05	1.80	3.68
42	1.04	1.77	3.62
43	1.02	1.74	3.56
44	1.01	1.72	3.51
45	0.99	1.69	3.46
46	0.98	1.67	3.41
47	0.96	1.64	3.36
48	0.95	1.62	3.31
49	0.94	1.6	3.27
50	0.92	1.58	3.23
51	0.91	1.56	3.18
52	0.9	1.54	3.14
53	0.89	1.52	3.10
54	0.88	1.50	3.07
55	0.87	1.48	3.03
56	0.86	1.47	2.99
57	0.85	1.45	2.96
58	0.84	1.43	2.92
59	0.83	1.42	2.89
60	0.82	1.4	2.86
65	0.78	1.32	2.71
70	0.73	1.25	2.59
75	0.70	1.19	2.48
80	0.66	1.14	2.38
85	0.64	1.09	2.29
90	0.61	1.05	2.21
95	0.58	1.01	2.13
100	0.56	0.97	2.06
105	0.54	0.94	2.00
110	0.52	0.91	1.94
115	0.51	0.88	1.88
120	0.49	0.86	1.84

Figure 3.4-1. Rainfall IDF Curve – Fort Collins

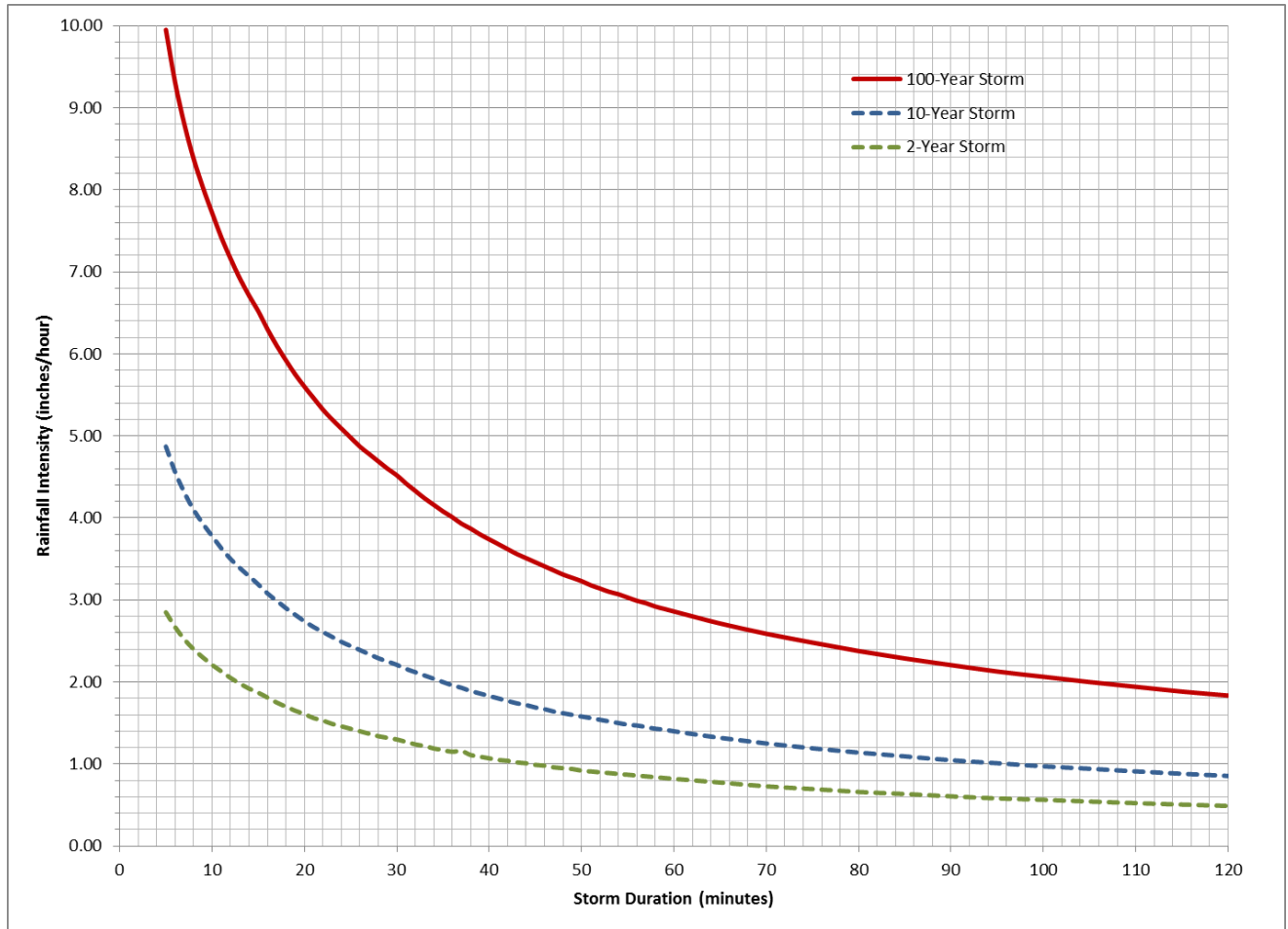

4.0 SWMM

This section is for project sites that require the use of the Stormwater Management Model (SWMM) to determine storm hydrograph routing and is the only method that is able to assess the overall performance of multiple detention basins in parallel or in series in a particular project site or watershed.

Reference: The theory and methodology for reservoir routing is not covered in this Manual as this subject is well described in many hydrology reference books. The EPA SWMM Reference Manuals, dated January 2016, have been utilized in preparing the information in this section of the Manual.

4.1 Input Parameters

Table 4.1-1 provides required input values to be used for SWMM modeling.

Basin and conveyance element parameters must be computed based on the physical characteristics of the site.

Table 4.1-1. SWMM Input Parameters

Depth of Storage	
Impervious Areas	0.1 inches
Pervious Areas	0.3 inches
Infiltration Parameters	
Maximum	0.51 in/hr
Minimum	0.50 in/hr
Decay Rate	0.0018 in/sec or 6.48 in/hr
Zero Detention Depth	1%
Manning's "n"	
Pervious Surfaces	0.250
Impervious Surfaces	0.016

For Overall Drainage Plan (ODP) and Project Development Plan (PDP) submittals, when surface types may not yet be known, land uses may be used to estimate impervious percentages. Table 4.1-2 lists the percent imperviousness for common types of land uses in the City.

Table 4.1-2. Land Use - Percent Impervious

Land Use	Percent Impervious (%)
Residential	
Urban Estate	30
Low Density	50
Medium Density	70
High Density	90
Commercial	
Commercial	80
Industrial	90
Undeveloped	
Open Lands, Transition	20
Greenbelts, Agriculture	2
Offsite Flow Analysis (when Land Use not defined)	45

[Reference:](#) For further guidance regarding zoning classifications, refer to the Land Use Code, Article 4.

For Final Plan (FP) submittals, impervious values must be based on the proposed land surface types. Refer to **Table 4.1-3** for recommended percent impervious values.

Table 4.1-3. Surface Type – Percent Impervious

Surface Type	Percent Impervious (%)
Hardscape or Hard Surface	
Asphalt, Concrete	100
Rooftop	90
Recycled Asphalt	80
Gravel	40
Pavers	40
Landscape or Pervious Surface	
Playgrounds	25
Lawns, Sandy soil	2
Lawns, Clayey soil	2

The composite imperviousness is obtained using the following formula:

$$I = \frac{\sum_{i=1}^n (I_i \times A_i)}{A_t}$$

Equation 5-6

Where: I = Composite Imperviousness, %

I_i = Imperviousness for Specific Area (A_i), %

A_i = Area of Surface with Imperviousness of I_i , acres or square feet

n = Number of different surfaces to be considered

A_t = Total Area over which I is applicable, acres or square feet

4.1.1 Intensity-Duration-Frequency Curves for SWMM

The hyetograph input option must be selected when creating SWMM input files. Hyetographs for the 2-year, 5-year, 10-year, 25-year, 50-year, and 100-year Fort Collins rainfall events are provided in **Table 4.1-4**.

Table 4.1-4. IDF Table for SWMM

Duration (min)	Intensity 2-year (in/hr)	Intensity 5-year (in/hr)	Intensity 10-year (in/hr)	Intensity 25-year (in/hr)	Intensity 50-year (in/hr)	Intensity 100-year (in/hr)
5	0.29	0.40	0.49	0.63	0.79	1.00
10	0.33	0.45	0.56	0.72	0.90	1.14
15	0.38	0.53	0.65	0.84	1.05	1.33
20	0.64	0.89	1.09	1.41	1.77	2.23
25	0.81	1.13	1.39	1.80	2.25	2.84
30	1.57	2.19	2.69	3.48	4.36	5.49
35	2.85	3.97	4.87	6.30	7.90	9.95
40	1.18	1.64	2.02	2.61	3.27	4.12
45	0.71	0.99	1.21	1.57	1.97	2.48
50	0.42	0.58	0.71	0.92	1.16	1.46
55	0.35	0.49	0.60	0.77	0.97	1.22
60	0.30	0.42	0.52	0.67	0.84	1.06
65	0.20	0.28	0.39	0.62	0.79	1.00
70	0.19	0.27	0.37	0.59	0.75	0.95
75	0.18	0.25	0.35	0.56	0.72	0.91
80	0.17	0.24	0.34	0.54	0.69	0.87
85	0.17	0.23	0.32	0.52	0.66	0.84
90	0.16	0.22	0.31	0.50	0.64	0.81
95	0.15	0.21	0.30	0.48	0.62	0.78
100	0.15	0.20	0.29	0.47	0.60	0.75
105	0.14	0.19	0.28	0.45	0.58	0.73
110	0.14	0.19	0.27	0.44	0.56	0.71
115	0.13	0.18	0.26	0.42	0.54	0.69
120	0.13	0.18	0.25	0.41	0.53	0.67

4.1.2 Conveyance Element Methodology

Embedded conveyance elements, if used, must begin at the midpoint of the sub-basin in order to appropriately represent the basin based on its actual physical characteristics. Embedded conveyance elements are only allowed in undeveloped watersheds.

4.1.3 Basin Width

Traditionally, the basin width calculation requirement in Fort Collins has been calculated as the area of the basin divided by the length of the basin. The basin length is defined as the length of the concentrated flow (Equation 4-9).

$$W = \frac{A}{L_{Ch}}$$

Equation 5-7

Where:

W = Width of the sub-basin

A = Area of the sub-basin

L_{Ch} = Length of the concentrated flow path

This method is perhaps more appropriate for idealized, rectangular shaped basins. For basins that are irregular in shape or have a concentrated flow channel that is off center, the Design Engineer should explore one of three additional methods presented in the EPA SWMM Hydrology Manual for more accurate runoff results. Early coordination with FCU staff is encouraged to discuss the most appropriate method for determining width.

4.2 Flow Analysis

Conditions may arise where a dynamic wave modeling analysis may not provide sufficient information on the operation of drainage facilities. An example of this is when analyzing detention basins interconnected by culverts or storm sewers where release rates and basin volumes may be affected. In such cases when further evaluation is required, FCU staff may require that additional analysis be provided for a complete and accurate analysis of the proposed drainage facilities. Additional analysis may include unsteady flow analysis using hydrographs generated from SWMM.

In addition, flow analysis will also need to consider any other limiting capacity factors, such as existing or proposed inlet capacities that may affect the amount of runoff that is able to contribute to a storm piping system.

Chapter 6: Detention

Contents

- 1.0 Overview 1
 - 1.1 Master Plan Requirements 1
 - 1.2 Drain Time Criteria 2
 - 1.3 Site Planning for Drainage Systems 3
 - 1.3.1 Utilizing Regional Facilities 4
 - 1.4 Multi-Purpose Uses 4
 - 1.5 Offsite Flows 5
 - 1.6 Prohibited Detention Systems 5
- 2.0 Water Quantity Detention 5
 - 2.1 Hydrologic Design Methods and Criteria 5
 - 2.2 SWMM 6
 - 2.3 Modified FAA Procedure 6
 - 2.4 Detention Basin Volume 7
 - 2.4.1 Stage-Storage 7
 - 2.5 Alternative to Quantity Detention (“Beat the Peak”) 8
- 3.0 Detention Basin Components 9
 - 3.1 Forebay 9
 - 3.2 Spillway 10
 - 3.3 Outlet Works 10
 - 3.3.1 Quantity Detention Orifice Plate 11
 - 3.3.2 Water Quality Orifice Plate 12
 - 3.3.3 Trash Racks 16
 - 3.4 Maintenance 17
- 4.0 Alternative Detention Facilities 18
 - 4.1 Underground Detention Facilities 18
 - 4.1.1 Policy 18
 - 4.1.2 Design Criteria for All Underground Detention Systems 19
 - 4.1.3 Additional Design Criteria for Detention in Permeable Pavers Void Spaces 20
 - 4.1.4 Additional Design Criteria for Detention in Underground Chambers or Pipes 20

Chapter 6: Detention

- 4.2 Detention Basins in Parking Areas 21
- 4.3 Spill Control for Gas Stations and Vehicle Maintenance Facilities 21
- 4.4 Pumped Detention Basins..... 22

1.0 Overview

As stated in 2016 UDFCD Manual, “detention facilities are used to manage stormwater quantity by attenuating peak flows during major storm events. They can also be designed to enhance stormwater quality by incorporating design components to promote sedimentation, infiltration, and biological uptake. This Chapter provides guidance for the analysis and design of detention facilities that are implemented independently or in combination with stormwater quality facilities.”

Detention facilities represent a significant portion of open space within both public and private developments in the City. The City encourages site planning that allows for multipurpose, attractive detention facilities that are safe and maintainable while also meeting the release rate requirements as stipulated by the hydrology of the site and applicable law.

This Chapter presents information that is specific to the City of Fort Collins and may be a significant deviation from the information presented in the UDFCD Manuals. Utilizing UDFCD methodologies for detention calculations may not be accepted by FCU.

1.1 Master Plan Requirements

Detention of stormwater runoff is required, as directed by individual Master Drainage Plan(s). A hydrologic routing analysis is also required. In basins where a Master Drainage Plan does not exist or has not been approved, the City will require stormwater detention in accordance with the criteria set forth in this Manual as well as when such stormwater detention is deemed necessary to protect irrigation ditches, reservoirs and other facilities, and downstream properties.

TYPICAL RELEASE RATES:

ALLOWABLE RELEASE RATES DURING THE 100-YEAR STORM EVENT ARE LIMITED TO THE 2-YEAR HISTORIC RELEASE RATE, OR LESS, AS SPECIFICALLY PRESCRIBED IN THE APPLICABLE MASTER DRAINAGE PLAN.

Onsite detention is required for all development projects. The required minimum detention volume and maximum release rate(s) for the developed condition 100-year recurrence interval storm must be determined in accordance with the conditions and regulations established in the appropriate Master Drainage Plan(s) for that area of the City, for the development and in accordance with the criteria set forth in this Manual.

1.2 Drain Time Criteria

All detention facilities constructed after August 5, 2015, including Alternative Detention Facilities (as discussed in Section 4.0 of this Chapter), must meet the requirements of “stormwater detention and infiltration facilities” under CRS §37-92-602(8) which was enacted through Senate Bill 15-212. This statute was signed into law in May 2015 and became effective on August 5, 2015. It provides certain legal protections for detention facilities in Colorado if they meet the statute’s criteria. The statute’s criteria for such facilities are summarized here for convenience purposes only and the statute, as it may be interpreted by Colorado courts, controls in the event of any discrepancies between the statute and this Manual.

All detention facilities must:

- 1) Be solely operated for stormwater management;
- 2) Be owned and operated by a governmental entity or is subject to oversight by a governmental entity;
- 3) Continuously releases or infiltrates at least 97% of all runoff from a rainfall event that is less than or equal to the 5-year storm within 72 hours after the end of the event;
- 4) Continuously releases or infiltrates at least 99% of the runoff from a rainfall event that is greater than the 5-year storm within 120 hours after the end of the event; and
- 5) Operates passively and does not provide active water treatment processes for the stormwater.

The water detained or released by detention facilities:

- 1) Shall not be used for any purpose, including, without limitation, by substitution or exchange, by the entity that owns, operates, or has oversight over the facility or that entity's assignees, and is available for diversion in priority after release or infiltration; and

**FOR DETENTION FACILITIES
CONSTRUCTED AFTER AUGUST 5,
2015, THE DESIGN ENGINEER IS
REQUIRED TO PROVIDE THE
FOLLOWING:**

1. DOWNLOAD AND FILL OUT THE STORMWATER DETENTION AND INFILTRATION DESIGN DATA SHEET THAT SHOWS THAT THE DETENTION FACILITY IS MEETING DRAIN TIME REQUIREMENTS.
2. PROVIDE NOTICE, PURSUANT TO CRS §37-92-602(8)(D) ON THE STATEWIDE NOTIFICATION PORTAL WEBSITE PRIOR TO CITY ACCEPTANCE OF THE “OVERALL SITE AND DRAINAGE CERTIFICATION”. THE “OVERALL SITE AND DRAINAGE CERTIFICATION” CHECKLIST INCLUDES DIRECTIONS FOR WHAT THE CITY WILL REQUIRE TO BE UPLOADED TO THE WEBSITE.

- 2) Shall not be released for the subsequent diversion or storage by the person that owns, operates, or has oversight over the facility or that entity's assignees.

References:

[Colorado Senate Bill 15-212:](#)

[UDFCD Memo regarding New Colorado Revised Statute \(CRS\) §37-92-602 \(8\):](#)

[Colorado Division of Water Resources Administrative Statement Regarding the Management of Stormwater Detention Facilities and Post-Wildland Fire Facilities in Colorado:](#)

<http://water.state.co.us/DWRIPub/Documents/DWR%20Storm%20Water%20Statement.pdf>

1.3 Site Planning for Drainage Systems

Stormwater drainage infrastructure, such as channels, storm sewers, and detention facilities provide conveyance, water quality treatment and flood control for controlled release rates. When space requirements are considered, the provision for adequate drainage becomes a competing use for space. Therefore, adequate provision must be made in the site plan for drainage space requirements. This may entail the dedication of adequate right-of-way or easements during the development review process, in order to minimize potential conflict with other land uses.

The City requires that all drainage facilities be designed in a manner that provides a gravity-driven positive outfall into a natural drainage way such as a river or creek, or a component of or a tributary to the public storm drainage infrastructure system. Positive outfall in this context refers to the provision that all sites must be designed to drain with a gravity system to the public infrastructure system or

PLANNING FOR DRAINAGE:

- ALLOW ADEQUATE SPACE FOR DRAINAGE FACILITIES
- EASEMENT DEDICATION MAY BE NECESSARY
- SEPARATE LEGAL TRACT REQUIRED FOR DRAINAGE FACILITIES SERVING MORE THAN 3 RESIDENTIAL LOTS
- GRAVITY OUTFALL IS ALWAYS REQUIRED

natural drainage way(s). Outfall to a sump, drywell or “bubbler” is not considered a positive, gravity-driven system and is not typically allowed for any major storm conveyance systems.

Urban development is not permitted immediately downstream of existing or proposed emergency spillways or in areas that may act as spillways for canals, dams, or embankments impounding stormwater.

Stormwater detention is required when a development is proposed and there is an increase in impervious area greater than 1000 square feet. For project sites located within the Old Town

DETENTION THRESHOLDS:

- >1000 SQUARE FEET OF ADDED IMPERVIOUSNESS
- >5000 SQUARE FEET OF ADDED IMPERVIOUSNESS IN OLD TOWN BASIN
- PARKING LOT DETENTION ALLOWED (QUANTITY DETENTION ONLY) UP TO 12" MAXIMUM DEPTH

Master Drainage Basin, onsite detention is required when there is an increase in impervious area greater than 5000 square feet. Detention requirements are based on the newly added impervious areas only and previously existing impervious surface area is allowed to release runoff from the site at an undetained rate.

Parking lot detention for water quantity is allowed as long as it is not deeper than twelve inches (12"). See Section 4.2 of this Chapter for more information.

In designing drainage systems, the City requires that no undue burden be placed on the owners of single family lots by the placement of large storm drainage conveyance or detention facilities on their property. In order to prevent or minimize such occurrences, all storm drainage channels, pipes, and water quality or detention facilities serving more than three (3) properties must be located within tracts dedicated as drainage easements to the City.

1.3.1 Utilizing Regional Facilities

Onsite detention requirements may be deemed met where there are existing regional conveyance and/or detention facilities that have been sized with the capacity to accommodate flows from the fully-developed basin that includes the subject site. Typically, areas with regional detention are identified within one of the Master Drainage Plans and pertinent system information is provided to the site applicant by FCU staff. If applicable, when utilizing public facilities, any requirements for cost sharing or reimbursement to the City must be met.

SECONDARY USES IN DETENTION BASINS:

THE MS4 PERMIT SHOULD BE REVIEWED FOR COMPLIANCE ANY TIME SECONDARY USES ARE PROPOSED FOR DETENTION BASIN AREAS.

1.4 Multi-Purpose Uses

Detention basins can be designed to both meet the engineering requirements and provide an attractive diverse space. A detention basin can serve as a multi-use area, wildlife habitat, picturesque scene, entry experience or educational opportunity while maintaining the necessary functions of stormwater

2.0 Water Quantity Detention

detention and water quality improvement. Stormwater facilities should be considered an opportunity for aesthetic interest and natural integration rather than solely necessary features of a development.

For detention basins that are intended to serve as multipurpose areas, any active recreation or gathering areas may need to be placed in areas where the frequency of stormwater inundation is minimized. Likewise, secondary uses that would create added sediment loading or pollutants in the detention basin should not be planned unless a high level of maintenance will be provided. Examples of secondary uses that may add sediment or pollutant loads are dog parks and community gardens.

[Reference: CDPS General Permit Stormwater Discharges Associated with Municipal Separate Storm Sewer Systems \(MS4s\)](#)

1.5 Offsite Flows

If there are offsite tributary areas that contribute runoff to a project site, the total tributary area must be accounted for in the design of the drainage systems by routing the runoff generated by that offsite area safely through the site. Offsite flows do not need to be detained and released at historic rates.

1.6 Prohibited Detention Systems

- 1) Detention basin that is located within, under or on the roof of a building is prohibited.
- 2) On-stream stormwater detention is prohibited. Off-stream detention is the only stormwater detention method allowed for development sites in the City of Fort Collins. An off-stream detention facility collects and treats runoff from the proposed development site before entering the drainage way.
- 3) Detention that does not have a positive outfall or a system that outfalls to a drywell or sump.

2.0 Water Quantity Detention

2.1 Hydrologic Design Methods and Criteria

There are two detention basin sizing methodologies approved by FCU: the Rational Formula-based “Modified Federal Aviation Administration (FAA) Procedure” and the Stormwater Management Model (SWMM). In general, the chosen methodology should follow the basin size limitations listed in **Table 2.1-1**. The City is the determining authority with respect to the appropriate methodology to use under uncertain circumstances.

Table 2.1-1: Detention Calculation Method

Project Size *	Detention Calculation Method
< 5 acres	Modified FAA Required
5-20 acres	Modified FAA or SWMM Accepted
≥20 acres	SWMM Required

*Project Size must include any offsite runoff that is tributary to the subject site

Note about the UDFCD Manual: Because of the Master Drainage Plans detention requirements, the City does not allow for detention basins to be designed with the “full-spectrum detention” method that is described in the UDFCD Manual.

2.2 SWMM

For project sites equal to or greater than 20 acres, the use of a Stormwater Management Model (SWMM) is required.

If there are upstream detention facilities within the watershed that contribute and route runoff into the site being designed, hydrograph routing methods must be employed to allow for the upstream facilities to be included in the overall SWMM model.

Reference: The theory and methodology for reservoir routing is not covered in this Manual as this subject is well described in many hydrology reference books.

2.3 Modified FAA Procedure

The Modified FAA Procedure (1966) detention sizing method as modified by Guo (1999a), provides a reasonable estimate of volume requirements for detention facilities. This method provides sizing for one level of peak control only and not for multi-stage control facilities.

The input required for this Modified FAA volume calculation procedure includes:

- A = area of the catchment tributary to the detention facility (acres)
- C = runoff coefficient
- Q_{out} = allowable maximum release rate from the detention facility (cfs)
- T_c = time of concentration for the tributary catchment (minutes)
- I = rainfall intensity (inches/hour) at the site taken from Chapter 4: Hydrology Standards, for the relevant return frequency storms

The calculations are best set up in a tabular (spreadsheet) form with each 5-minute increment in duration being entered in rows and the following variables being entered, or calculated, in each column:

- 1) Storm Duration Time, T (minutes), up to 120 minutes

2.0 Water Quantity Detention

- 2) Rainfall Intensity, I (inches per hour)
- 3) Inflow volume, V_i (cubic feet), calculated as the cumulative volume at the given storm duration using the equation:

$$V_i = CIA (60T) \quad \text{Equation 6-1}$$

- 4) Calculated outflow volume, V_o , (cubic feet), given the maximum allowable release rate, Q_{out} (cfs), over the duration T :

$$V_o = Q_{out} (60 T) \quad \text{Equation 6-2}$$

- 5) Required detention volume, V_s (cubic feet), calculated using the equation:

$$V_s = V_i - V_o \quad \text{Equation 6-3}$$

The value of V_s increases with time, reaches a maximum value, and then starts to decrease. The maximum value of V_s is the required detention volume for the detention facility.

Note about UDFCD Manual: Please note that the UDFCD excel-based spreadsheets are not allowed to be used to calculate required detention volumes because they utilize Denver region rainfall data. The Design Engineer will be required to establish their own spreadsheet for calculating basin volume requirements based on the Modified FAA Procedure documented above using Fort Collins IDF curves.

2.4 Detention Basin Volume

2.4.1 Stage-Storage

A relationship between the water surface elevation and detention basin volume, commonly referred to as a “stage-storage” curve, needs to be developed. This relationship, in conjunction with the “stage-discharge” relationship will provide the required detention volume. An initial detention basin design must be created and a “stage-storage” curve developed that corresponds to the design.

The available detention volume shall be based on the following formula:

$$V = \frac{D}{3} (A + B + \sqrt{AB}) \quad \text{Equation 6-4}$$

Where V = Volume between two contours, ft^3

D = Depth between contours, feet

A = Area of bottom contour, ft^2

B = Area of top contour, ft^2

[Note about UDFCD Manual: The UD-Detention_v2.35 excel-based spreadsheet, Basin tab](#) may be allowed to aid in calculating the provided basin capacity and “stage-storage” curve.

2.5 Alternative to Quantity Detention (“Beat the Peak”)

For development sites that are adjacent to major drainage or water ways, the **“Beat the Peak”** procedure described in this Section allows for Design Engineers to analyze the timing of a hydrograph from the development site relative to the hydrograph on a nearby drainage or water way. If the development site hydrograph can be shown to “beat the peak” under the methodology described below on the nearby drainage or water way, then the development site may be allowed to eliminate stormwater detention on the site.

[Reference:](#) The review and approval of a “beat the peak” analysis will need to follow the variance procedure as outlined in Chapter 2: Development Submittal Requirements Section 8.0.

Included here is a step-by-step procedure for this analysis:

- 1) Existing Condition hydrologic model – Update to include the proposed development without the required detention. Existing Condition model is available from FCU staff upon request.

The model should then be checked to ensure that:

- 1) Downstream discharges,
- 2) Basin volumes, and
- 3) Basin water surface elevations do not increase as a result of the proposed development

- 2) Master Plan – Selected Plan Condition hydrologic model – Update to include the proposed development without the required detention. Selected Plan Condition model is available from FCU staff upon request.

The model should be checked to ensure that:

- 4) Downstream discharges,
- 5) Basin volumes, and
- 6) Basin water surface elevations do not increase as a result of the proposed development.

- 3) If the development meets all 6 of the no-impact criteria for the Existing and the Selected Plan condition models, and all other related requirements are met, then a written

3.0 Detention Basin Components

variance request may be submitted for the “no detention” scenario and is still subject to staff review and approval.

- 4) If the development fails to meet any of the 6 listed criteria, then the detention requirements and allowable release rates based on the pertinent Master Drainage Plan will be enforced.

In regards to this design procedure:

- The City is the determining authority on whether a site is considered “adjacent to major drainage or water ways”. Generally speaking, “adjacent” means directly next to the water way or a parcel that is contiguous to the water way. Parcels separated from the water way by other parcels or public rights-of-way are not considered “adjacent” for this purpose.
- The City reserves the right to request additional analyses, including hydraulic analyses to assess the effects of any revised discharges.
- The City reserves the right to deny the request to eliminate onsite detention even if the “beat the peak” analysis shows no impact.
- Water quality provisions (refer to Chapter 6: Water Quality) will still be a requirement of the site design and will not be waived as a result of these analyses.
- Adequate conveyance of the 100-year storm from the site to the drainage or water way must be provided if no detention is provided at the site.
- FCU will retain and maintain an updated version of the Existing Condition and the Selected Plan Condition hydrologic models to track the cumulative effect of any and all allowed “no-detention” projects. The Design Engineer must submit the updated models for City files.

3.0 Detention Basin Components

[Reference: Detention basin layout, geometrical requirements and grading criteria are provided in Chapter 8: Grading of this Manual.](#)

3.1 Forebay

Pre-treatment in the form of a forebay is a feature that can, but is not required, to be included in detention basins for the purpose of removing trash and large sediment from stormwater instead of allowing the sediment to be deposited throughout the detention basin. Forebays are to be located at storm pipe outlets or other concentrated points of inflow into the detention basin. They are typically constructed with a concrete bottom or other hard surface bottom to allow for easy maintenance and sediment removal and include a berm or curb around the perimeter with a notched outlet.

3.0 Detention Basin Components

The inclusion of forebays into detention basins is encouraged if the Design Engineer believes they are necessary. However, FCU does not require forebays and does not consider these to be an applicable LID technique.

[Reference](#): UDFCD Manual provides design parameters for forebays. Design Engineers may utilize this or other design guides if including forebays within detention basins.

3.2 Spillway

An emergency spillway shall be designed to safely convey the 100-year overtopping discharge for the entire area tributary to the detention facility, assuming a fully-developed condition in the tributary area and a fully-clogged outlet works condition.

When a detention facility falls under the jurisdiction of the Colorado Division of Water Resources, a.k.a. Office of the State Engineer (SEO), the spillway's design storm is prescribed by the SEO and the spillway embankment and/or detention basin are considered "jurisdictional".

If the detention facility is not a "jurisdictional" structure, the size of the spillway design storm must be based upon analysis of the risk and consequences of a facility failure. Generally, embankments should be fortified against and/or have spillways that, at a minimum, are capable of conveying the total peak 100-year storm discharge from a fully developed total tributary catchment. In addition, detailed analysis of downstream hazards must be performed and may indicate that the embankment protection and/or spillway design needs to be sized for events much larger than the 100-year design storm.

Flow over a horizontal spillway can be calculated using the following equation for a horizontal broad-crested weir:

$$Q = C_{BCW} LH^{1.5} \quad \text{Equation 6-5}$$

Where: Q = Discharge, cfs

C_{BCW} = Broad-crested weir coefficient, dimensionless (ranges from 2.6 to 3.0)

L = Length of weir, ft

H = Head above weir crest, ft

3.3 Outlet Works

Included below is a typical configuration for an extended detention outlet structure. **Figure 3.3-1** includes the general features and layout of the basic components of a typical outlet structure. This figure is not a construction detail. The Design Engineer will be required to refer to the City construction details for additional design requirements for final design of an outlet structure.

Figure 3.3-1. Extended Detention Outlet Structure

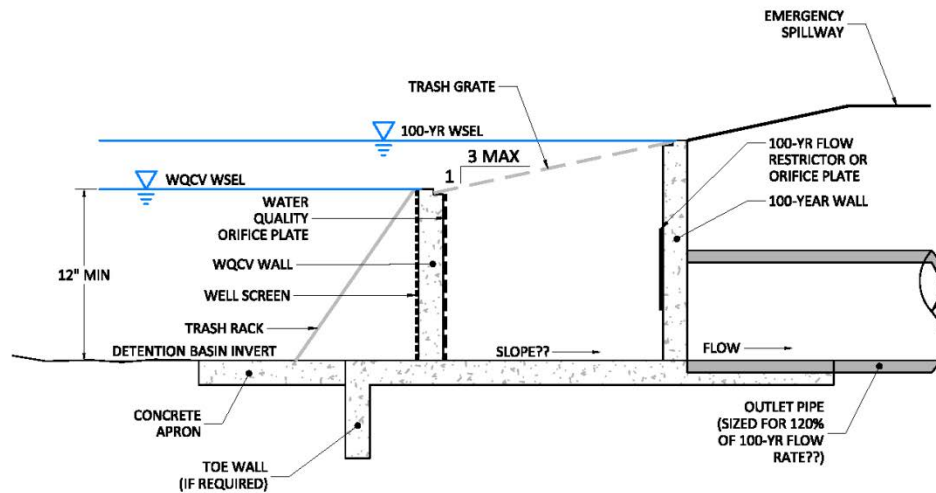

3.3.1 Quantity Detention Orifice Plate

As with the entire facility, the outlet works for detention facilities shall be designed to meet Colorado Revised Statute §37-92-602 (8) drain time requirements. These requirements are discussed in more detail in Section 1.2 of this Chapter.

With drain time requirements in mind, the outlet works for an extended detention basin shall be designed to release the WQCV over a 40-hour period.

Quantity detention is released through a low-flow outlet structure. The minimum outlet pipe size for use in detention facilities is 15-inch diameter (or equivalent) when located in a public right-of-way. Orifice plates may be utilized to reduce flows from the minimum pipe sizes. The outlet flow capacity shall be estimated using the orifice equation shown below:

$$Q = C_o A \sqrt{2gh}$$

Equation 6-6

- Where: Q = Discharge, cfs
 C_o = Orifice coefficient, dimensionless
 A = Cross-sectional area of orifice, ft²
 g = Gravitational constant (32.2 ft/sec²)
 h = Effective head, ft

If the outlet from the detention basin is under free outfall, the effective head is measured from the centroid of the orifice to the upstream water surface elevation. If the downstream jet or orifice is

3.0 Detention Basin Components

submerged, then the effective head is the difference in elevation between the upstream and downstream water surfaces.

For square-edged, uniform orifice entrance conditions, a discharge coefficient of 0.61 should be used. For rough-edged orifice entrance conditions, a discharge coefficient of 0.4 should be used.

3.3.2 Water Quality Orifice Plate

The Water Quality Capture Volume (WQCV) is released through a low-flow perforated orifice plate. The perforations can be determined using the following equation:

$$a = \frac{WQCV}{0.013D_{WQ}^2 + 0.22D_{WQ}^{-0.10}} \quad \text{Equation 6-7}$$

Where: a = Area per row of orifices (spaced on 4" centers), in²

WQCV = Water quality capture volume, acre-feet

D_{WQ} = Depth of WQCV, ft

The water quality orifice plate perforations may also be found using **Figure EDB-3** (UDFCD, 6/2002) shown below.

3.0 Detention Basin Components

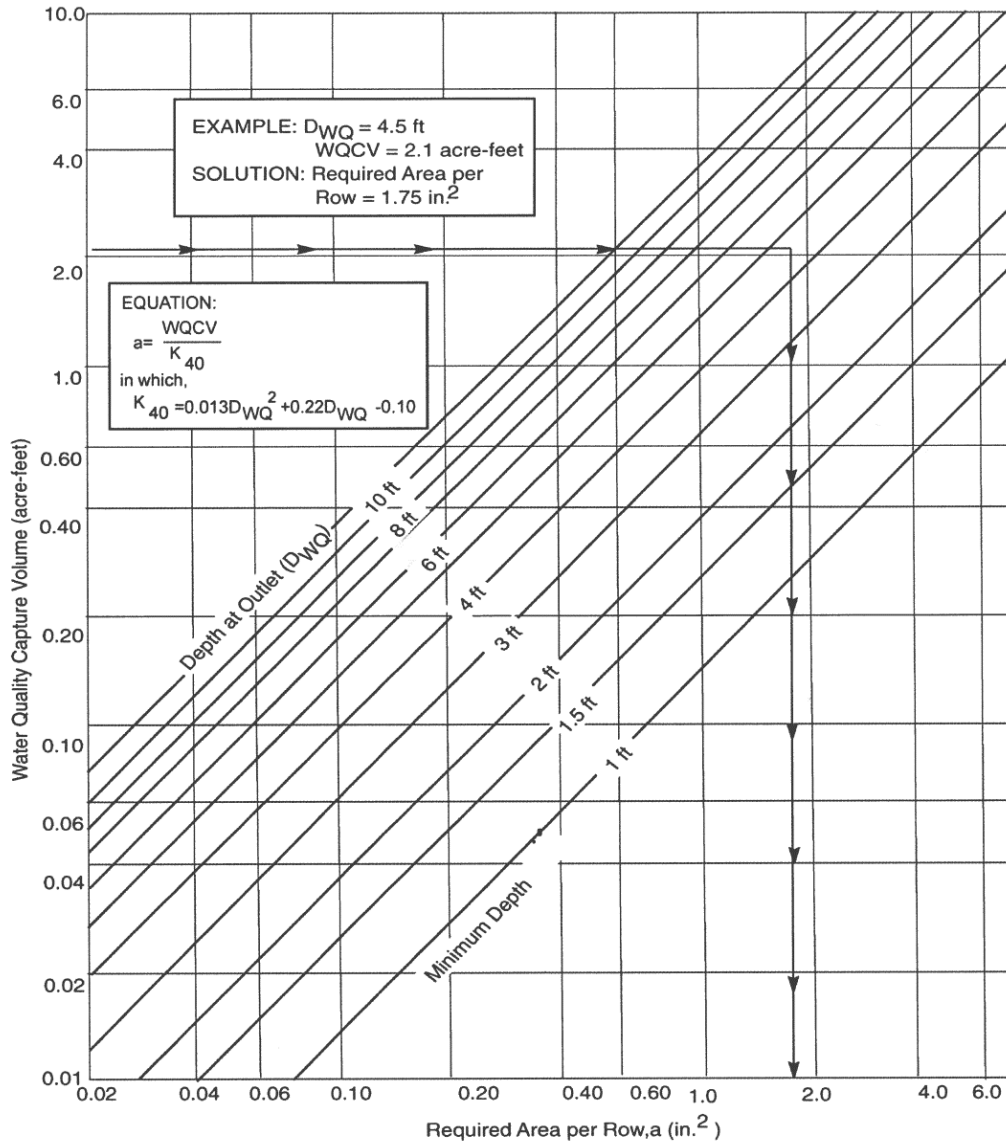

**Figure EDB-3—Water Quality Outlet Sizing: Extended Detention Basin (Dry)
 With 40-hour Drain Time for Capture Volume**

3.0 Detention Basin Components

The perforation pattern on the orifice plate (i.e. number of columns and exact hole diameter) can be found utilizing **Figure 5** (UDFCD, 12/2004) and **Table 6a-1** (UDFCD, 12/2004) shown below.

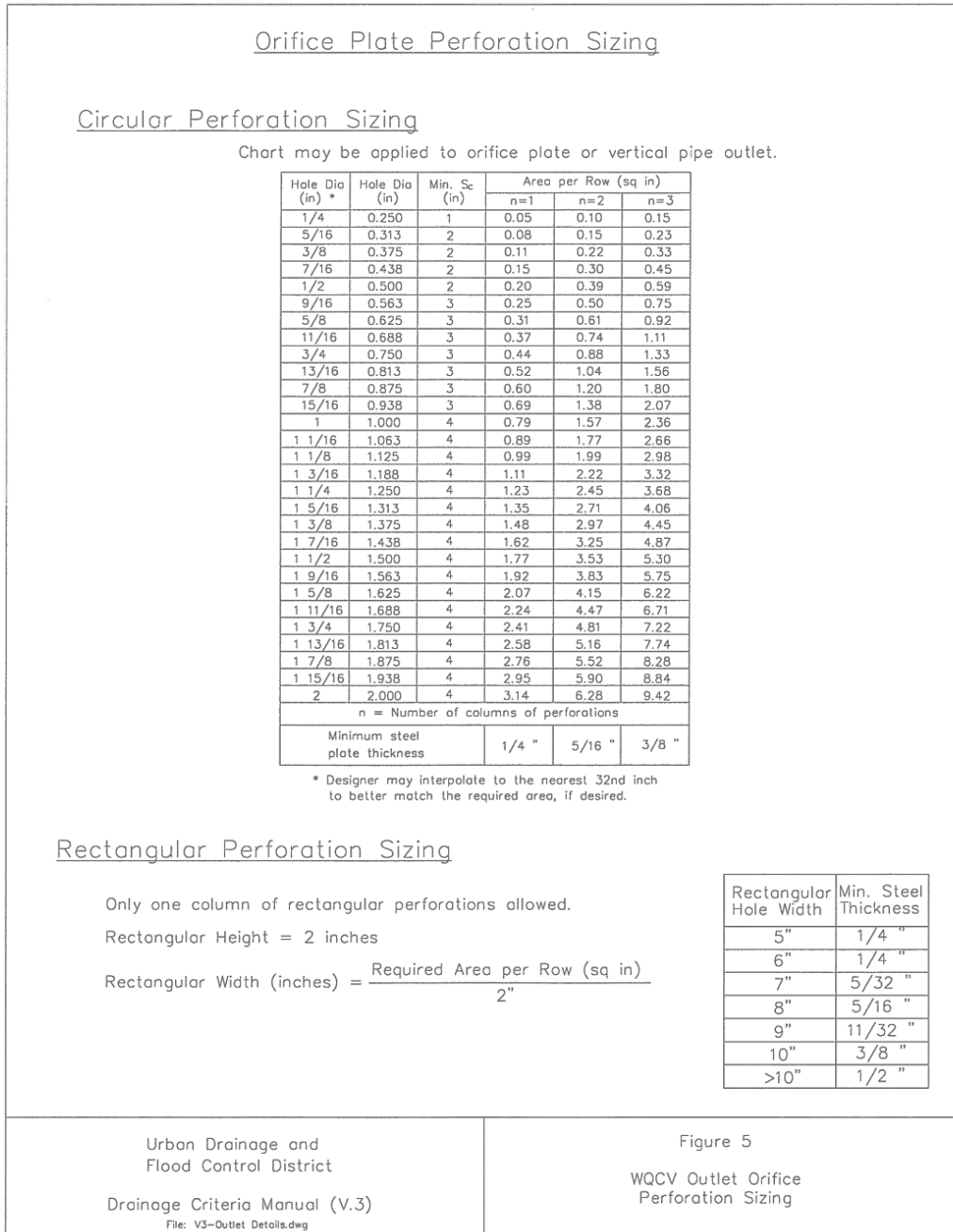

Figure 5—WQCV Outlets Orifice Perforation Sizing.

3.0 Detention Basin Components

Table 6a-1—Standardized WQCV Outlet Design Using Circular Openings
(2" diameter maximum)

Minimum Width ($W_{opening}$) of Opening for a Well-Screen Type Trash Rack.

Requires a minimum water depth below the lowest perforation of 2'-4".

See Figure 6-a for Explanation of Terms.

Maximum Dia. of Circular Opening (inches)	Width of Trash Rack Opening ($W_{conc.}$) Per Column of Holes as a Function of Water Depth H Below Lowest Perforation					Maximum Number of Columns
	H=2.0'	H=3.0'	H=4.0'	H=5.0'	H=6.0'	
≤ 0.25	3 in.	3 in.	3 in.	3 in.	3 in.	14
≤ 0.50	3 in.	3 in.	3 in.	3 in.	3 in.	14
≤ 0.75	3 in.	6 in.	6 in.	6 in.	6 in.	7
≤ 1.00	6 in.	9 in.	9 in.	9 in.	9 in.	4
≤ 1.25	9 in.	12 in.	12 in.	12 in.	15 in.	2
≤ 1.50	12 in.	15 in.	18 in.	18 in.	18 in.	2
≤ 1.75	18 in.	21 in.	21 in.	24 in.	24 in.	1
≤ 2.00	21 in.	24 in.	27 in.	30 in.	30 in.	1

Table 6a-2—Standardized WQCV Outlet Design Using Circular Openings
(2" diameter maximum).

US Filter™ Stainless Steel Well-Screen¹ (or equal) Trash Rack Design Specifications.

Max. Width of Opening	Screen #93 VEE Wire Slot Opening	Support Rod Type	Support Rod, On-Center, Spacing	Total Screen Thickness	Carbon Steel Frame Type
9"	0.139	#156 VEE	¾"	0.31'	¾"x1.0" flat bar
18"	0.139	TE .074"x.50"	1"	0.655	¾" x 1.0 angle
24"	0.139	TE .074"x.75"	1"	1.03"	1.0" x 1½" angle
27"	0.139	TE .074"x.75"	1"	1.03"	1.0" x 1½" angle
30"	0.139	TE .074"x1.0"	1"	1.155"	1 ¼"x 1½" angle
36"	0.139	TE .074"x1.0"	1"	1.155"	1 ¼"x 1½" angle
42"	0.139	TE .105"x1.0"	1"	1.155"	1 ¼"x 1½" angle

¹ US Filter, St. Paul, Minnesota, USA

Reference: Information presented above for the Water Quality Orifice Plate calculations and the well screen design specifications are from the UDFCD Manual Volume 3, Revision dates 6/2002 and 12/2004.

3.3.3 Trash Racks

Trash racks are required to be installed as part of outlet structures (at the upstream end of piping systems) to help address safety concerns and provide some ease in maintenance. Trash racks must be of sufficient size such that they do not interfere with the hydraulic capacity of the outlet structure. Trash racks typically consist of either a bar grate, a closed-mesh grate, or an open grate. Examples are shown in the figure below.

Bar grates and closed-mesh grates are appropriate for horizontal or sloping surfaces, while open grates are only appropriate for vertical surfaces. Closed-mesh grates are typically more appropriate for pedestrian or high traffic areas but require more maintenance because these catch smaller debris.

Trash racks are not allowed to be installed at the downstream end of piping systems. These may trap people or debris, impede flows, hinder maintenance or fail to prevent access to the pipe. On the other hand, desirable conditions can be achieved through careful design and positioning of the pipe outlet as well as through careful landscape placement for screening.

The figure below indicates the required minimum trash rack open area based on outlet size.

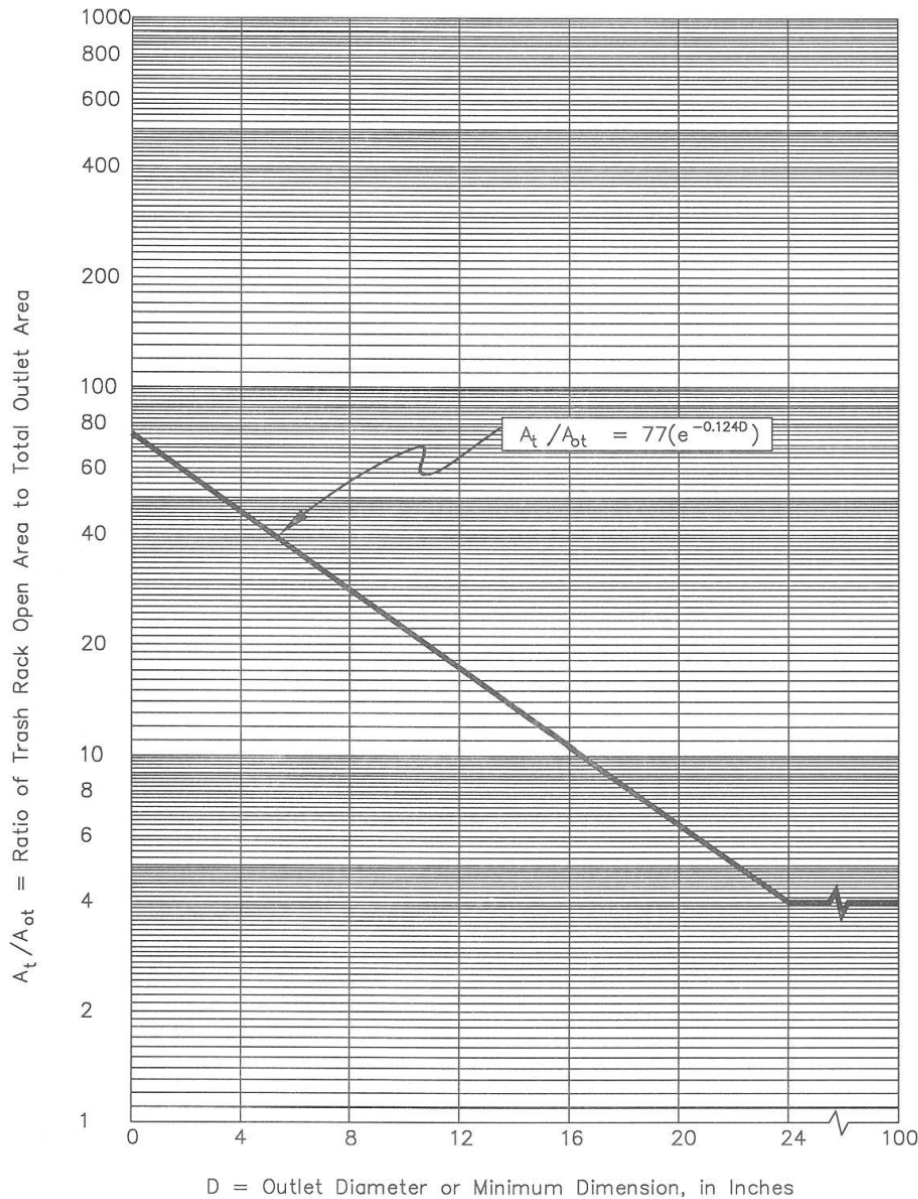

[Reference:](#) Information included here for trash racks is from the 2016 and 2011 UDFCD Manual, Storage Chapters.

3.4 Maintenance

To reduce maintenance and avoid operational problems, outlet structures must be designed with no moving parts other than the trash rack (i.e. use only pipes, orifices, and weirs). Manually and/or electrically operated gates shall be avoided. To reduce maintenance, outlets should be designed with openings as large as possible, compatible with the depth-discharge relationships desired and with water

4.0 Alternative Detention Facilities

quality, safety, and aesthetic objectives in mind. One way of doing this is to use a larger outlet pipe and to construct orifice(s) in the headwall to reduce outflow rates. Outlets should be robustly designed to lessen the chances of damage from debris or vandalism. Avoid the use of thin steel plates as sharp-crested weirs to help prevent potential accidents, especially with children. Trash racks must protect all outlets.

All detention systems shall satisfy the following design and operating criteria:

- 1) Standard Operating Procedures (SOPs) that detail the operation and maintenance of the proposed drainage system are included as a part of every Development Agreement for every project site. A final copy of the approved Development Agreement and SOPs must be kept onsite by the party responsible for facility maintenance and referenced as often as required for proper maintenance.
- 2) If the City deems that the detention system is not being maintained in accordance with the SOPs specified in the Development Agreement, the system owner will be sent written notice by FCU to conduct corrective measures within 30 days. The City will conduct a follow-up inspection after 30 days and if corrective measures have not been addressed then FCU shall have the right to enter the property for proper maintenance of the system. FCU may then charge the owner time and material costs incurred by FCU to take corrective action and maintain the system.

4.0 Alternative Detention Facilities

4.1 Underground Detention Facilities

4.1.1 Policy

Underground detention has been formally allowed by City Council in January 2016 pursuant to Ordinance No. 006, 2016.

[Reference: The underground detention ordinance, Ordinance No. 006, 2016, can be found on the City of Fort Collins website.](#)

The use of structural underground detention will be allowed as long as the system can demonstrate a gravity outfall for stormwater release and is made accessible for proper long-term maintenance and functionality and meets the requirements of this Manual. If an underground detention system is proposed, a system owner must seek approval of such a system through the development review process, where the underground system may be approved upon a determination that the requirements of this section are satisfied and that no adverse impacts are expected to result from the proposed system.

4.0 Alternative Detention Facilities

4.1.2 Design Criteria for All Underground Detention Systems

The purpose of this subsection is to set forth technical criteria to be utilized for the use of underground stormwater detention as a permanent structural control measure to meet water quality and/or stormwater runoff detention requirements.

Any proposed underground stormwater detention system, including gravel reservoirs in porous interlocking concrete pavement (PICP) systems and chambers or pipes, shall satisfy the following design and operating criteria:

- 1) Runoff must flow through a pre-treatment facility (e.g. water quality chamber) before it enters the underground detention system
- 2) A gravity outfall is required at the invert of the underground detention system.
- 3) Inspection ports are required to be installed as a part of the system for inspection and maintenance purposes.
- 4) Groundwater level must be documented to be at least two foot (2') below reservoir bottom during the high groundwater period of the calendar year.
- 5) Underdrain pipes are required. The underdrain pipe shall be at least four inches (4") in diameter. Underdrain cleanouts are required at all changes in direction. If the minimum underdrain size results in a release rate larger than allowed under these criteria, a restrictor plate in a manhole must be added at the point of outflow.
- 6) Other utilities such as water mains, sewer mains or dry utilities are not allowed to be located within or below the extents of the underground detention system.
- 7) Potential lateral movement of contained stormwater outside the limits of the detention chamber must be controlled, accounted and designed for in a manner that ensures the structural integrity of adjacent structures and infrastructure.
- 8) Drainage easements are required for all underground detention facilities. This includes the entire detention basin area and all appurtenances necessary for the outfall.
- 9) Standard Operating Procedures (SOPs) that detail the operation and maintenance of the proposed drainage system are included as a part of every Development Agreement for every project site. A final copy of the approved Development Agreement and SOPs must be kept onsite by the party responsible for facility maintenance and referenced as often as required for proper maintenance.
- 10) If the City deems that the underground detention system is not being maintained in accordance with the SOPs specified in the Development Agreement, the system owner will be sent written notice by FCU to conduct corrective measures within 30 days. The City will conduct a follow-up inspection after 30 days and if corrective

4.0 Alternative Detention Facilities

measures have not been addressed then FCU shall have the right to enter the property for proper maintenance of the system. FCU may then charge the owner time and material costs incurred by FCU to take corrective action and maintain the system.

4.1.3 Additional Design Criteria for Detention in Permeable Pavers Void Spaces

The following additional design and operating criteria are for detention reservoirs located in gravel void spaces of Porous Interlocking Concrete Pavement (PICP) (permeable pavement) systems. In addition to the criteria set forth in the “All Systems” section above, the following additional criteria apply to any PICP system with a gravel layer void space.

- 1) The maximum allowable detention volume within the subsurface void spaces is up to a maximum of 1 acre-foot, with the maximum allowable assumption of 30% void space.
- 2) Additional detention volume is allowed within chambers or pipes.
- 3) A PICP parking lot surface must be designed with a minimum 0.5% slope.
- 4) An overflow inlet must be included as part of the overall design in the event that the PICP system fails and to ensure that stormwater enters the detention system.
- 5) Aggregates used for subbase material must assume a maximum of 30% void space for available detention volume in order to account for potential sedimentation. (Note that construction specifications for permeable pavers shall be referenced during design and construction of paver areas. Construction specifications are not included in this Manual.)

4.1.4 Additional Design Criteria for Detention in Underground Chambers or Pipes

The following additional criteria apply to any detention system using underground chambers and/or pipes.

- 1) All chambers or pipes must be placed with a minimum slope of 0.2%.
- 2) Maintenance access must be provided, at a minimum, at the point of inflow and point of outflow from the system. The accesses must be such that they would allow human access to inspect the functionality of the system. Confined space entry must be considered into the design and maintenance responsibilities outlined within the SOPs and/or Development Agreement.
- 3) All pipes or chambers must be vacuum truck accessible through manholes.
- 4) An underdrain system is required for open bottom chambers.
- 5) The minimum pipe size allowed for detention in pipes is fifteen inches (15”).

4.0 Alternative Detention Facilities

- 6) The structural system capacity must be designed to support AASHTO HS20 (fire truck) loading, as well as anticipated lifetime AASHTO 18,000 lb. equivalent single axle loads (ESALs).

4.2 Detention Basins in Parking Areas

The maximum permissible detention basin depth within parking areas is 12 inches (12"). For commercial properties only, an exception may be granted by FCU for ponding depths of up to 18 inches (18"), if the percentage of spaces with ponding depths of greater than 12 inches is less than 25% of the total parking spaces provided.

In all circumstances, twelve inches (12") of freeboard must be provided between the high water elevation and the minimum opening elevations of adjacent buildings.

Signage will be required for parking areas that include stormwater detention to alert the public that stormwater ponding within the parking areas may occur. Format and information included in the signage must be included in the Utility Plans and approved by FCU.

The water quality component of extended detention basins is not allowed within the extents of the parking lot area. The water quality portion of the detention basin must be located on vegetated areas only and will not be allowed to encroach onto paved areas.

4.3 Spill Control for Gas Stations and Vehicle Maintenance Facilities

Spill control structures are required for all new and redeveloping gas stations and vehicle maintenance facilities. In addition to emergency spill response procedures, such as the use of absorbent booms, structural spill controls must be used to protect all areas downstream of the site including roadways, drainage channels, storm sewer systems, wetlands, creeks and tributaries from petroleum products and other pollutants that are stored and handled at gas stations and vehicle maintenance facilities.

The spill control structure can be a below-grade concrete vault and should be placed in a location on the site that allows for spills to be directed toward it. Low flows, both pollutant spills and runoff from small storms, should be able to be directed into the control structure. Larger storm flows may be directed into the control structure but more likely will overtop a curb or bypass the spill structure and runoff toward the site detention basin.

The spill control structure or vault must have a minimum capacity of 150 gallons. The vault should be covered for safety although ventilation should be provided to allow for evaporation between storms.

4.4 Pumped Detention Basins

Permanent retention or pumped detention basins are not allowed to serve as permanent water quantity or quality control measures for any development within the City or its GMA. Pumped detention basins are sometimes necessary as a temporary measure to hold water until a permanent, gravity outfall is available. FCU may approve such temporary pumped detention basin in a Development Agreement or other written agreement, as an interim solution, until a permanent outfall is built. Approval of pumped detention facilities will be based upon a known improvement that will allow for a gravity outfall to be constructed and the known improvement must be understood to be installed within 5 years. This required timeframe and related terms and conditions must be included in the Development Agreement for the development. If approved, these basins must be designed to meet the requirements of CRS §37-92-602(8).

When temporary use of a pumped detention basin is proposed as a solution, design requirements are as follows:

- 1) Basin is sized to capture, at a minimum, the runoff equal to two times the 2-hour, 100-year storm plus one foot of freeboard.
- 2) The facility must be situated and designed so that when it overtops, no human-occupied or critical structures (e.g., electrical vaults, homes, etc.) will be flooded, and no catastrophic failure at the facility (e.g., loss of dam embankment) will occur.
- 3) When a trickle outflow can be accepted downstream or a small conduit can be built, it shall be provided and sized in accordance with the locally approved release rates, and be capable of emptying the full volume pursuant to the requirements of CRS §37-92-602(8).
- 4) All pumped detention ponds must be built with a redundant pumping system and with a concrete hard surface at the bottom of the structure that is capable of evacuating the full volume pursuant to the requirements of CRS §37-92-602(8).
- 5) Pumping systems must include complete design of the pumps, sump pit or pump housing.
- 6) All pumped detention basins must be built and operated in accordance with all applicable State and Federal laws, including but not limited to CRS §37-92-602(8) regarding drain time requirements.

Chapter 7: Water Quality

Contents

- 1.0 Overview 1
- 2.0 Four Step Process..... 2
- 3.0 BMP Selection 7
 - 3.1 Storage-Based vs Conveyance-Based BMPs 7
 - 3.2 Treatment Train 7
 - 3.3 Online vs Offline Facility Locations 8
 - 3.4 Maintenance and Sustainability..... 8
- 4.0 Water Quality Detention..... 8
- 5.0 Hydrologic Basis of the WQCV 9
 - 5.1 Development of the WQCV..... 9
 - 5.2 Optimizing the Capture Volume 10
 - 5.3 Attenuation of the WQCV (BMP Drain Time) 11
 - 5.4 Calculation of the WQCV 11
- 6.0 Low Impact Development..... 13
 - 6.1 General Requirements 14
 - 6.2 Permeable Pavement..... 15
 - 6.3 Bioretention (Rain Gardens) 17
 - 6.4 Sand Filter 17
 - 6.5 Linear Bioretention 18
 - 6.6 Underground Filtration 19
 - 6.7 Vegetated Buffer..... 20
 - 6.8 Constructed Wetland Channel / Pond 21
 - 6.9 Drainage Easements for LID..... 21
 - 6.9.1 LID Systems in Other Utility Easements..... 22
 - 6.9.2 LID Systems Not Accessible Via Easement..... 22
- 7.0 References 23
 - 7.1 Extended Detention Basin (EDB) Fact Sheet T-5 from UDFCD Manual 23
 - 7.2 Outlet Structures Fact Sheet T-12 from UDFCD Manual 37

1.0 Overview

The focus of this Chapter is on the frequently occurring rainfall events, those which have the greatest overall impact on the quality of receiving waters. The contents of this Chapter include design guidance for Design Engineers in selecting, maintaining and implementing permanent best management practices (BMPs) for development sites that minimize water quality impacts from stormwater runoff.

FCU suggests that the Design Engineer begins the development process with a clear understanding of the seriousness of stormwater quality management from regulatory and environmental perspectives, and implement a holistic planning process that incorporates water quality up front in the overall site development process. FCU requires that water quality treatment systems for stormwater are installed for all applicable development sites, including the incorporation of enhanced water quality treatment for stormwater, which has been required since 2013.

The physical and chemical characteristics of stormwater runoff changes as urbanization occurs, requiring comprehensive planning and management to reduce adverse effects on receiving waters. As stormwater flows across roads, rooftops and other hard surfaces, pollutants are picked up and then discharged to streams and lakes. Additionally, the increased frequency, flow rate, duration and volume of stormwater discharges due to urbanization can result in the scouring of rivers and streams, degrading the physical integrity of aquatic habitats, stream function, and overall water quality (EPA, 2009)

Generally, standard water quality treatment is required for all portions of development sites that are not treated through LID systems.

STANDARD WQ TREATMENT
+ LID REQUIREMENTS
100% OF SITE TREATED

Many of the concepts presented in this Chapter are based upon the research and practices developed by UDFCD (e.g. WQCV and the Four Step Process). These practices have become design criteria for many communities throughout the region, including Fort Collins. The UDFCD Manual design criteria and design tools that are utilized by FCU are presented herein;

however, FCU has further, sometimes more restrictive design requirements than those presented in the UDFCD Manual, which are also provided in this Chapter.

An LID Implementation Manual (provided in Appendix C) is included as a part of this Manual. The LID Implementation Manual is a comprehensive document that includes an LID technique selection matrix, design guidance and construction detailing for all the LID systems commonly accepted by FCU. The LID Implementation Manual is considered a user’s guide, whereas, the information presented in this

Chapter focuses on the design criteria for standard and enhanced water quality systems. Designers will find that this Chapter is to be utilized in conjunction with the LID Implementation Manual.

2.0 Four Step Process

UDFCD has long recommended a Four Step Process for receiving water protection that focuses on reducing runoff volumes, treating the water quality capture volume (WQCV), stabilizing streams and implementing long-term source controls. The Four Step Process pertains to management of smaller, frequently occurring events, as opposed to larger storms for which drainage and flood control infrastructure are sized. Implementation of these four steps helps to achieve compliance with stormwater permit requirements (i.e. City’s MS4 permit). Added benefits of implementing the complete process can include improved site aesthetics through functional landscaping amenities that also provide stormwater quality benefits.

Figure 2.0-1. The Four Step Process for stormwater quality management

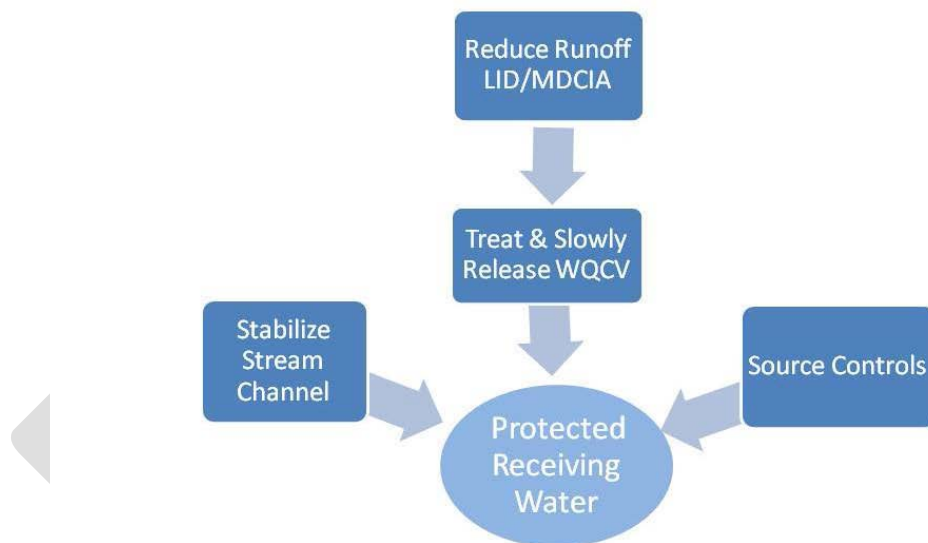

Step 1. Employ Runoff Reduction Practices

To reduce runoff peaks, volumes and pollutant loads from urbanizing areas, implement LID strategies, including Minimizing Directly Connected Impervious Area (MDCIA). For every site, look for opportunities to route runoff through vegetated areas, where possible, by sheet flow. LID practices reduce unnecessary impervious areas and route runoff from impervious surfaces over permeable areas to slow runoff (increase time of concentration) and promote infiltration.

Differences between LID and Conventional Stormwater Quality Management

LID is a comprehensive land planning and engineering design approach to managing stormwater runoff with a goal of replicating the pre-development hydrologic regime of urban and developing watersheds. Given the increased regulatory emphasis on LID, volume reduction and mimicking pre-development hydrology, questions may arise related to the differences between conventional stormwater management and LID. For example, MDCIA is emphasized as the first step in stormwater quality planning and the LID Implementation Manual provides guidance on LID techniques such as linear bioretention, bioretention, permeable pavement systems and pollution prevention (pollutant source controls). Although these practices are all key components of LID, LID is not limited to a set of practices targeted at promoting infiltration. Key components of LID, in addition to individual BMPs, include practices such as:

- An overall site planning approach that promotes conservation design at both the watershed and site levels. This approach to development seeks to “fit” a proposed development to the site, integrating the development with natural features and protecting the site’s natural resources. This includes practices such as preservation of natural areas including open space, wetlands, soil with high infiltration potential and stream buffers. Minimizing unnecessary site disturbances (e.g. grading, compaction) is also emphasized.
- A site design philosophy that emphasizes multiple controls distributed throughout a development, as opposed to a single treatment facility.
- The use of swales and open vegetated conveyances, as opposed to curb and gutter systems.

Even with LID practices in place, most sites will also require centralized flood control facilities. In some cases, site constraints may limit the types of LID techniques that can be implemented, whereas in other cases, developers and engineers may have significant opportunities to integrate LID techniques that may be overlooked due to the routine nature and familiarity of conventional approaches. This Manual provides design criteria and guidance for both LID and conventional stormwater quality management.

Key LID techniques include:

- **Conserve Existing Amenities:** During the planning phase of development, identify portions of the site that add value and should be protected or improved. Such areas may include mature trees, stream corridors, wetlands and Type A/B soils with higher infiltration rates. In order for this step to provide meaningful benefits over the long-term, natural areas must be protected from compaction during the construction phase. Consider temporary construction fence for this purpose. In areas where disturbance cannot practically be avoided, rototilling and soil amendments should be integrated to restore the infiltration capacity of areas that will be restored with vegetation. Additional natural resource protection standards may apply on a particular site, per Section 3.4.1 of the Land Use Code.

- **Minimize Impacts:** Consider how the site lends itself to the desired development. In some cases, creative site layout can reduce the extent of paved areas, thereby saving on initial capital cost of pavement and then saving on pavement maintenance, repair, and replacement over time. Minimize imperviousness, including constructing streets, driveways, sidewalks and parking lot aisles to the minimum widths necessary, while still providing for parking, snow management, public safety and fire access. When soils vary over the site, concentrate new impervious areas over Type C and D soils, while preserving Type A and B soils for landscape areas and other permeable surfaces. Maintaining natural drainage patterns, implementing sheet flow (as opposed to concentrated flow), and increasing the number and lengths of flow paths will all reduce the impact of the development.
- **Permeable pavement** techniques are common LID practices that may reduce the effects of paved areas. The use of various permeable pavement techniques as alternatives to paved areas can significantly reduce site imperviousness.
- **Minimize Directly Connected Impervious Areas (MDCIA):** Impervious areas should drain to pervious areas. Use non-hardened drainage conveyances where appropriate. Route downspouts across pervious areas, and incorporate vegetation in areas that generate and convey runoff. Three key BMPs include:
 - **Vegetated Buffers:** Sheet flow over a vegetated buffer slows runoff and encourages infiltration, reducing effects of the impervious area.
 - **Linear bioretention:** Like vegetated buffers, the use of linear bioretention instead of storm sewers slows runoff and promotes infiltration, also reducing the effects of imperviousness.
 - **Bioretention (rain gardens):** The use of distributed on-site vegetated features such as rain gardens can help maintain natural drainage patterns by allowing more infiltration onsite. Bioretention can also treat the WQCV, as described in the Four Step Process.

Practical Tips for Volume Reduction and Better Integration of Water Quality Facilities

(Adapted from: Denver Water Quality Management Plan, WWE et al. 2004)

- *Consider stormwater quality needs early in the development process. When left to the end of the site development process, stormwater quality facilities will often be shoe-horned into the site, resulting in few options. When included in the initial planning for a project, opportunities to integrate stormwater quality facilities into a site can be fully realized. Dealing with stormwater quality after major site plan decisions have been made is too late and often makes implementation of LID designs more difficult.*
- *Take advantage of the entire site when planning for stormwater quality treatment. Stormwater quality and flood detention is often dealt with only at the low corner of the site, and ignored on the remainder of the site. The focus is on draining runoff quickly through inlets and storm sewers to the detention facility. In this "end-of-pipe" approach, all the runoff volume is concentrated at one point and designers often find it difficult to fit the required detention into the space provided. This can lead to use of underground BMPs that can be difficult to maintain or deep, walled-in basins that detract from a site and are also difficult to maintain. Treating runoff over a larger portion of the site reduces the need for big corner basins and allows implementation of LID principles.*
- *Place stormwater in contact with the landscape and soil. Avoid routing storm runoff from pavement to inlets to storm sewers to offsite pipes or concrete channels. The recommended approach places runoff in contact with landscape areas to slow down the stormwater and promote infiltration. Permeable pavement areas also serve to reduce runoff and encourage infiltration.*
- *Minimize unnecessary imperviousness, while maintaining functionality and safety. Smaller street sections or permeable pavement in fire access lanes, parking lanes, overflow parking, and driveways will reduce the total site imperviousness.*
- *Select treatment areas that promote greater infiltration. Bioretention, permeable pavements, and sand filters promote greater volume reduction than extended detention basins, since runoff tends to be absorbed into the filter media or infiltrate into underlying soils.*

Step 2. Implement BMPs That Provide a WQCV with Slow Release

After runoff has been minimized, the remaining runoff should be treated through capture and slow release of the WQCV. The LID Implementation Manual provides design guidance for BMPs providing treatment of the WQCV, including permeable pavement systems with subsurface water quality treatment or detention, bioretention, extended detention basins, sand filters and constructed wetland ponds. This Chapter also provides the step-by-step procedure to calculate the WQCV.

Step 3. Stabilize Streams

During and following development, natural streams are often subject to bed and bank erosion due to increases in frequency, duration, rate and volume of runoff. Although Steps 1 and 2 help to minimize these effects, some degree of stream stabilization is required. The streams and drainageways within Fort Collins are typically included in Master Drainage Plans which would identify needed channel stabilization measures. These measures not only protect infrastructure such as utilities, roads and trails, but are also important to control sediment loading from erosion of the channel itself, which can be a significant source of sediment and associated constituents, such as phosphorus, metals and other naturally occurring constituents. If stream stabilization is implemented early in the development process, it is far more likely that natural stream characteristics can be maintained with the addition of grade control to accommodate future development. Targeted fortification of a relatively stable stream is typically much less costly than repairing an unraveled channel.

Step 4. Implement Site Specific and Other Source Control BMPs

Site specific needs such as material storage or other site operations require consideration of targeted source control BMPs. This is often the case for new development or significant redevelopment of an industrial or commercial site. Some examples of implementing this practice are:

- To locate trash collection or enclosure areas away from storm drainage or LID facilities so that highly concentrated and polluted runoff from that area has the opportunity to be cleaned prior to runoff into the storm drain.
- To locate dog parks in areas away from detention basins and to educate and enforce pick up practices for dog owners.
- To locate community gardens in areas that are outside of a detention basin to prevent chemical and sediment loading in the detention basin.
- To locate material storage (during construction) away from storm drainage facilities (i.e. stockpiles of backfill or landscape materials)

3.0 BMP Selection

3.1 Storage-Based vs Conveyance-Based BMPs

BMPs in this Manual generally fall into two categories: 1) storage-based and 2) conveyance-based. Storage-based BMPs provide the WQCV and include bioretention/rain gardens, extended detention basins, sand filters, constructed wetland ponds and underground storage, filtration and infiltration systems. Conveyance-based BMPs include linear bioretention (linear bioretention), permeable pavement systems, constructed wetlands, channels and other BMPs that improve quality and reduce volume but only provide incidental storage.

Conveyance-based BMPs can be implemented to help achieve objectives in Step 1 of the Four Step Process. Storage-based BMPs are critical for Step 2 of the Four Step Process. FCU does not require that sites include both storage and conveyance-based BMPs; however, site plans that use a combination of conveyance-based and storage-based BMPs can be used to better mimic pre-development hydrology.

3.2 Treatment Train

Advantages of treatment trains include:

- **Multiple processes for pollutant removal:** There is no "silver bullet" for a BMP that will address all pollutants of concern as a stand-alone practice. Treatment trains that link together complementary processes expand the range of pollutants that can be treated with a water quality system and increase the overall efficiency of the system for pollutant removal.

The term "treatment train" refers to multiple BMPs in series (e.g., a roof downspout draining to a bioswale draining to a rain garden draining to an extended detention basin.) Engineering research over the past decade has demonstrated that treatment trains are one of the most effective methods for management of stormwater quality (WERF 2004).
- **Redundancy:** Given the natural variability of the volume, rate and quality of stormwater runoff and the variability in BMP performance, using multiple practices in a treatment train can provide more consistent treatment of runoff than a single practice and provide redundancy in the event that one component of a treatment train is not functioning as intended.
- **Maintenance:** BMPs that remove trash, debris, coarse sediments and other gross solids are a common first stage of a treatment train. From a maintenance perspective, this is advantageous since this first stage creates a well-defined, relatively small area that can be cleaned out

4.0 Water Quality Detention

routinely. Downgradient components of the treatment train can be maintained less frequently and will benefit from reduced potential for clogging and accumulation of trash and debris.

3.3 Online vs Offline Facility Locations

The location of WQCV facilities within a development and watershed site requires thought and planning. A key decision involves whether to locate a BMP online or offline. Offline refers to locating a BMP such that all of the runoff from the upstream basin is intercepted and treated by the BMP prior to entering the receiving water. FCU requires that water quality treatment is provided at the site level (offline) before entering receiving waters. FCU will not allow water quality treatment systems to be installed on the receiving waters (online).

3.4 Maintenance and Sustainability

Maintenance needs to be considered early in the planning and design phase. Even when BMPs are thoughtfully designed and properly installed, they can become eyesores, breed mosquitoes, and cease to function if not properly maintained. BMPs are more effectively maintained when they are designed to allow easy access for inspection and maintenance and to take into consideration factors such as property ownership, easements, visibility from easily accessible points, slope, vehicle access, and other factors. FCU requires that design plans adhere to easement dedication requirements and design parameters for access. In addition, FCU requires that maintenance procedures (SOPs) are outlined for each BMP and included in the Development Agreement for each project site.

Sustainability of BMPs is based on a variety of considerations related to how the BMP will perform over time. For example, vegetation choices for BMPs determine the extent of supplemental irrigation required. Choosing native or drought-tolerant plants and seed mixes (as recommended in Chapter 4: Construction Control Measures) helps to minimize irrigation requirements following plant establishment. Other sustainability considerations include large development site conditions. For example, in larger sites with phased and ongoing development, clogging of infiltration BMPs is a concern. In such cases, a decision must be made regarding either how to protect and maintain infiltration BMPs, or whether to allow use of infiltration practices under these conditions.

4.0 Water Quality Detention

Development sites that are required to incorporate water quantity detention into the stormwater management system of the site may also incorporate “extended detention” within the quantity detention basin to meet the City’s standard water quality requirements.

[Reference:](#) Refer to the [BMP Fact Sheet T-5: Extended Detention Basin \(EDB\)](#) from the 2015 UDFCD Manual, Volume 3, Chapter 4, Section 2.0 for additional design information. This Fact Sheet is included in the Reference section at the end of this Chapter.

5.0 Hydrologic Basis of the WQCV

An extended detention basin is designed to empty (either completely or almost completely) after stormwater runoff ends. It is an adaptation of a detention basin used for water quantity, with the primary difference being the outlet design. The extended detention basin has a much smaller outlet, which extends the stormwater release time of more frequently occurring runoff events to facilitate pollutant removal. The outlet is designed so that stormwater release for the water quality capture volume (WQCV) is 40 hours.

Combining the water quality facility with the water quantity facility is a common design practice. When detention volume is sized for a site that also incorporates WQCV, the 100-year volume required for quantity detention must be added to the entire WQCV. In addition, the WQCV must account for providing water quality treatment to all stormwater runoff that is not otherwise treated through a Low Impact Development (LID) system. LID systems and requirements are discussed in Section 6.0 of this Chapter.

Soil type at the location of the extended detention basin should be determined during design. However, any exfiltration capacity should be considered a short-term characteristic because exfiltration will decrease over time as the soil is clogged with fine sediment and as the groundwater beneath the basin develops a mound that surfaces into that basin. Therefore, exfiltration rates are not allowed to be accounted for in detention basin volume design.

Other uses may be provided in the detention basin area, such as active or passive recreation. Active recreation facilities include ballparks, playing fields and picnic areas. However, the area within the WQCV is not well-suited for active recreation facilities because of frequent inundation and these facilities must be located outside of the WQCV pool. The area within the WQCV is better suited for passive recreation such as open space and wildlife habitat. See Section 3 of this Chapter for specific examples of facilities that should not be placed in detention areas.

5.0 Hydrologic Basis of the WQCV

5.1 Development of the WQCV

The purpose of designing BMPs based on the WQCV is to improve runoff water quality and reduce hydromodification and the associated impacts on receiving waters. Although some BMPs can help to remove pollutants and achieve modest reductions in runoff volumes for frequently occurring events in a "flow through" mode (e.g., linear bioretention, grass buffers or wetland channels), to address hydrologic effects of urbanization, a BMP must be designed to control the volume of runoff, either through detention, infiltration, evapotranspiration or a combination of these processes (e.g., rain gardens, extended detention basins or other storage-based BMPs). The following insert provides a brief background on the development of the WQCV.

The WQCV is based on an analysis of rainfall and runoff characteristics for 36 years of record at the Denver Stapleton Rain Gage (1948-1984) conducted by Urbonas, Guo, and Tucker (1989) and documented in Sizing a Capture Volume for Stormwater Quality Enhancement (available at www.udfcd.org). This analysis showed that the average storm for the Denver area, based on a 6-hour separation period, has duration of 11 hours and an average time interval between storms of 11.5 days. However, the great majority of storms are less than 11 hours in duration (i.e., median duration is less than average duration). The average is skewed by a small number of storms with long durations.

The data showed that 61% of the 75 storm events that occur on an average annual basis have less than 0.1 inches of precipitation. These storms produce practically no runoff and therefore have little influence in the development of the WQCV. Storm events between 0.1 and 0.5 inches produce runoff and account for 76% of the remaining storm events (22 of the 29 events that would typically produce runoff on an average annual basis). Urbonas et al. (1989) identified the runoff produced from a precipitation event of 0.6 inches as the target for the WQCV, corresponding to the 80th percentile storm event.

The WQCV for a given watershed will vary depending on the imperviousness and the drain time of the BMP, but assuming 0.1 inches of depression storage for impervious areas, the maximum capture volume required is approximately 0.5 inches over the area of the watershed. Urbonas et al. (1989) concluded that if the volume of runoff produced from impervious areas from these storms can be effectively treated and detained, water quality can be significantly improved.

5.2 Optimizing the Capture Volume

Optimizing the capture volume is critical. If the capture volume is too small, the effectiveness of the BMP will be reduced due to the frequency of storms exceeding the capacity of the facility and allowing some volume of runoff to bypass treatment. On the other hand, if the capture volume for a BMP that provides treatment through sedimentation is too large, the smaller runoff events may pass too quickly through the facility, without the residence time needed to provide treatment.

Small, frequently occurring storms account for the predominant number of events that result in stormwater runoff from urban catchments. Consequently, these frequent storms also account for a significant portion of the annual pollutant loads. Capture and treatment of the stormwater from these small and frequently occurring storms is the recommended design approach for water quality enhancement, as opposed to flood control facility designs that focus on less frequent, larger events.

5.0 Hydrologic Basis of the WQCV

The analysis of precipitation data at the Denver Stapleton Rain Gage revealed a relationship between the percent imperviousness of a watershed and the capture volume needed to significantly reduce stormwater pollutants (Urbonas, Guo, and Tucker, 1990). Subsequent studies (Guo and Urbonas, 1996 and Urbonas, Roesner, and Guo, 1996) of precipitation resulted in a recommendation by the Water Environment Federation and American Society of Civil Engineers (1998) that stormwater quality treatment facilities (i.e., post-construction BMPs) be based on the capture and treatment of runoff from storms ranging in size from "mean" to "maximized" storms. The "mean" and "maximized" storm events represent the 70th and 90th percentile storms, respectively. As a result of these studies, water quality facilities for the Colorado Front Range are recommended to capture and treat the 80th percentile runoff event. Capturing and properly treating this volume should remove between 80 and 90% of the annual TSS load, while doubling the capture volume was estimated to increase the removal rate by only 1 to 2%.

5.3 Attenuation of the WQCV (BMP Drain Time)

The WQCV must be released over an extended period to provide effective pollutant removal for post-construction BMPs that use sedimentation (i.e., extended detention basin and constructed wetland ponds). The extended period generally equates to a 40-hour drain time for the brim-full basin. Constructed wetland basins may have reduced drain times (12 hours or 24 hours) because the hydraulic residence time of the effluent is essentially increased due to the mixing of the inflow with the permanent pool.

When pollutant removal is achieved primarily through filtration such as in a sand filter or rain garden BMP, an extended drain time is still recommended to promote stability of downstream drainageways, but it can be reduced because it is not needed for effective pollutant removal. In addition to counteracting hydromodification, attenuation in filtering BMPs can also improve pollutant removal by increasing contact time, which can aid adsorption/absorption processes depending on the media. The minimum recommended drain time for a post-construction BMP is 12 hours.

5.4 Calculation of the WQCV

The first step in estimating the magnitude of runoff from a site is to estimate the site's total imperviousness. The total imperviousness of a site can be determined taking an area-weighted average of all of the impervious and pervious areas.

<p>STANDARD WATER QUALITY 40-HOUR DRAIN TIME REQUIRED</p> <p>LID SYSTEMS 12-HOUR DRAIN TIME REQUIRED</p>
--

The WQCV is calculated as a function of imperviousness and BMP drain time using the following equation and as shown in **Figure 5.4-1**:

$$WQCV = a(0.91I^3 - 1.19I^2 + 0.78I)$$

Equation 7-1

Where: WQCV = Water Quality Capture Volume, watershed inches

a = Coefficient corresponding to WQCV drain time (Table 5.4-1)

I = Imperviousness (%/100)

Table 5.4-1. Drain Time Coefficients for WQCV Calculations

Drain Time (hrs)	Coefficient (a)
12	0.8
40	1.0

Reference: The UD-BMP excel-based spreadsheet, RG and EDB tabs may be used to aid in calculating WQCV.

Figure 5.4-1 WQCV Based on BMP Drain Time

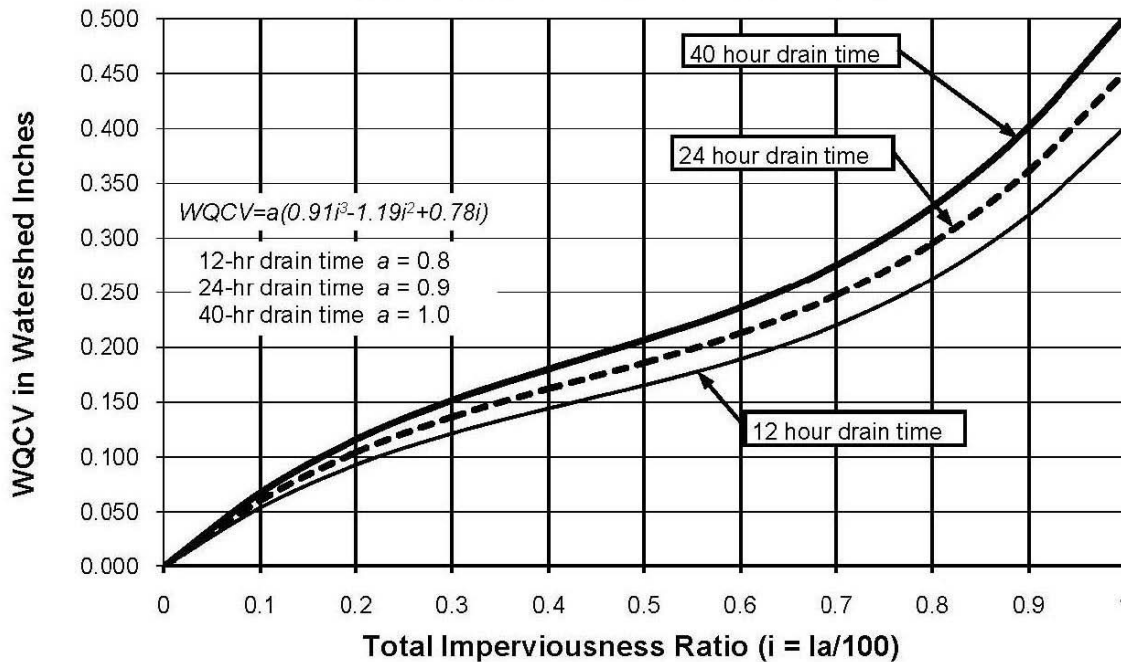

Once the WQCV in watershed inches is found from Figure 3.2-12 or using Equation 3.2-1, the required BMP volume in acre-feet can be calculated as follows:

$$V = \left(\frac{WQCV}{12}\right) Ax1.2$$

Equation 7-2

Where: V = required volume, acre-ft

A = tributary catchment area upstream, acres

WQCV = Water Quality Capture Volume, watershed inches

1.2 = to account for the additional 20% of required storage for sedimentation accumulation

Reference: Calculating effective imperviousness and quantifying volume reduction as discussed in the 2015 UDFCD Manual, Volume 3, Section 4.0 are not allowed. The City of Fort Collins does not allow for extended detention basins to be designed using the Excess Urban Runoff Volume (EURV) and Full-Spectrum Detention method, as described in the UDFCD Manual.

6.0 Low Impact Development

This Section of this Chapter presents information that is specific to the City of Fort Collins and may be a significant deviation from the information presented in the UDFCD Manuals. Utilizing UDFCD methodologies for Low Impact Development (LID) designs may not be accepted by FCU.

In February 2013, Fort Collins City Council adopted Ordinance No. 152, 2012, to incorporate provisions implementing LID principles; with the goal to declare that the purpose of the City Stormwater Utility is to provide an integrated, sustainable stormwater management program that reflects the community's values of protecting and restoring the City's watersheds. This was subsequently modified and updated in January 2016 with Ordinance No. 007, 2016 to allow for some added flexibility in the implementation of the LID policy.

Reference: Both the initial LID ordinance, [Ordinance No. 152, 2012](#), and the subsequent ordinance, [Ordinance No. 007, 2016](#), can be found on the City of Fort Collins website.

LID is simply defined as an integrated, sustainable stormwater management program that requires a distributed, closer to the source stormwater runoff control that simulates natural processes and relies mainly on filtration and infiltration to locally treat and manage stormwater runoff.

Integration of LID systems into the drainage design is required for all development projects in order to comply with the City's policies on LID, the requirements of this Manual, the City Code and the Land Use Code. LID systems provide a higher degree of stormwater quality treatment than that provided with standard water quality design. The implementation of LID systems requires one of the following two options:

- 1) 50% of the newly added or modified impervious area must be treated by LID techniques and 25% of new paved (vehicle use) areas must be pervious.
- 2) 75% of all newly added or modified impervious area must be treated by LID techniques.

Impervious surfaces are defined as hardscape surfaces that do not allow stormwater to infiltrate into the ground. Impervious surfaces include asphalt and concrete surfaces, concrete curbs, gutters, sidewalks, patios and rooftops. (Impervious surface areas must be assumed for single family residential lots when overall impervious areas are being determined for residential developments. The assumed areas must then be included in LID calculations.)

6.0 Low Impact Development

OPTIONS FOR MEETING WATER QUALITY TREATMENT REQUIREMENTS

50% SITE TREATED WITH "STANDARD" WATER QUALITY
+ 50% SITE TREATED WITH LID (INCLUDING PAVERS)
100% OF SITE TREATED (REQUIREMENTS MET)

OR

25% SITE TREATED WITH "STANDARD" WATER QUALITY
+ 75% SITE TREATED WITH LID
100% OF SITE TREATED (REQUIREMENTS MET)

“Added” impervious area stated in the two options above is further defined as existing vegetation (or pervious) areas becoming hardscape (or impervious) areas.

“Modified” impervious area stated in the two options above is further defined as existing impervious areas on an existing site being removed and replaced with other impervious surfaces through a redevelopment process (i.e.

existing asphalt surface becoming a rooftop surface). Mill and overlay of asphalt areas is not considered a “modified” impervious area.

“Paved” areas, as stated in option 1 above are generally considered to be private vehicle use areas only.

Reference: Refer to the [City of Fort Collins LID Implementation Manual in Appendix C](#) for detailed information and requirements on LID systems.

6.1 General Requirements

Included here are some general design requirements applicable for all types of LID system designs in Fort Collins.

- Overall added or modified impervious areas that amount to less than 1000 square feet (< 1000 sf) on a site will not require LID system treatment for water quality.
- For development sites that are adding or modifying 1000 square feet of imperviousness or more (≥ 1000 sf) are required to implement LID system treatment at the site. The LID system is allowed to treat existing imperviousness in exchange for the newly added imperviousness if the surface character is similar (e.g. existing pavement may be treated in lieu of newly added rooftop)
- For single-family residential developments, LID must be placed in tracts or common areas for ownership and maintenance by the HOA. LID systems installed as part of the development requirement shall not be placed on single-family lots.
- LID is not required for private, single-family residential improvement projects that are not a part of a larger subdivision project. (i.e. an existing lot in an older part of Fort Collins that is being re-built)

6.0 Low Impact Development

- LID systems are not allowed to be placed in the public right-of-way to treat runoff from development sites. Stormwater runoff from development must be treated within the confines of the development and therefore cannot be treated and/or placed within a public right-of-way. Stormwater runoff generated within the public right-of-way, however, is still required to be captured and treated for water quality.
- LID systems are generally required to be placed outside of a detention basin area.
- LID systems may only drain to drywells if a gravity outfall for the water quality storm is not available.
- LID systems are required to be sized for the entire area tributary to the LID basin (including any offsite contributing areas)
- LID systems are required to be placed outside of any existing wetlands (jurisdictional and non-jurisdictional), streams or other waters of the U.S.
- LID systems design must comply with the excerpts of the City of Fort Collins Landscape Design Standards and Guidelines for Stormwater and Detention Facilities, dated November 5, 2009 included as Appendix B to this Manual.

6.2 Permeable Pavement

The term “permeable pavement” is a general term to describe any one of several pavement systems that allow infiltration of water into the layers below the pavement through openings within the pavement surface. Use of permeable pavements is an accepted Low Impact Development (LID) practice in Fort Collins and is often used in combination with other BMPs to provide full treatment and slow release of the WQCV. In addition, there are some installations in Fort Collins that have also been designed with an outlet control and increased depth of aggregate material in order to provide quantity detention in excess of the water quality (80th percentile) storm event. Design considerations for permeable pavement systems are presented in the LID Implementation Manual, included in Appendix C. However, there are several design parameters specified below that are also required for all permeable pavement system designs specific to meeting the LID requirements for Fort Collins.

Figure 6.2-1. Design Criteria for Permeable Pavers (FCU)

<p>LOCATION</p> <ul style="list-style-type: none"> •Pavers installed within single-family or private driveway areas may not be applied toward the paver requirement of the LID ordinance. •Pavers along utility corridors is discouraged and will only be allowed on a case-by-case basis •Paver requirement generally only applies to sites with private vehicle use areas •For pavers to apply to the paver requirement of the LID ordinance, they must be placed in vehicle use areas. Pavers placed in sidewalks or other areas may be applied toward the LID requirements, but not the specific paver requirement 	<p>AREA</p> <ul style="list-style-type: none"> •If the project is installing less than 1000 sf of vehicle use area, then the paver requirement does not apply 	<p>RUN-ON</p> <ul style="list-style-type: none"> •Maximum allowable impervious area "running onto" a paver area is 3x the paver area, or a 3:1 ratio. •Note that Urban Drainage recommends a maximum 2:1 run-on ratio for tributary impervious areas. FCU allows a maximum of 3:1 run-on ratio. •Applicable run-on area is from impervious surfaces only (pavements and rooftops). Pervious surfaces are not required to be included in the run-on area calculation. 	<p>DETENTION</p> <ul style="list-style-type: none"> •Up to 1 acre-foot of detention is allowed in the subsurface media •Maximum allowable void space is 30% for detention volume calculations
<p>OVERFLOW</p> <ul style="list-style-type: none"> •overflow inlet or conveyance is required adjacent to paver areas 	<p>SLOPE</p> <ul style="list-style-type: none"> •Follow manufactureres recommendations for min and max surface slopes •Typical min surface slope 0.50% •Typical max surface slope 2.0% 	<p>SUBSURFACE SLOPES</p> <ul style="list-style-type: none"> •Follow manufactureres recommendations for min and max subgrade slopes •Typical min subgrade slope 0.50% 	<p>OTHER</p> <ul style="list-style-type: none"> •Impermeable liner required along paver subsurface where adjacent to buildings or other infiltration sensitive structures are present as determined by the Design Engineer •Underdrain piping is required •Underdrain cleanouts are required for flushing and inspection

6.3 Bioretention (Rain Gardens)

A BMP that utilizes bioretention is an engineered, depressed landscape area designed to capture and filter or infiltrate the water quality capture volume (WQCV). BMPs that utilize bioretention are frequently referred to as rain gardens or porous landscape detention areas (PLDs). In an effort to be consistent with terms most prevalent in the stormwater industry, this document generally refers to the treatment process as “bioretention” and to the BMP as a “rain garden”.

This infiltrating BMP requires consultation with a geotechnical engineer when proposed adjacent to a structure. A geotechnical engineer can assist with evaluating the suitability of soils, identifying potential impacts, and establishing minimum distances between the BMP and structures.

Design and construction detailing for bioretention systems, alternatively referred to as “rain gardens” are presented in the LID Implementation Manual in Appendix C. Additionally, included in **Figure 6.4-1** below are some key design parameters for rain gardens that are specific to Fort Collins.

NOTES ABOUT DRYWELLS

- DRYWELLS MAY BE UTILIZED AS AN OUTFALL FOR LID FACILITIES ONLY WHEN A GRAVITY OUTFALL TO THE SURFACE OR STORMWATER INFRASTRUCTURE IS NOT AVAILABLE
- DRYWELLS ARE NOT ALLOWED TO BE UTILIZED AS A PRIMARY OUTFALL FOR DETENTION BASINS OR STORM PIPING SYSTEMS
- INCLUSION OF A DRYWELL IN DESIGN PLANS MUST BE ACCOMPANIED BY A GEOTECHNICAL ANALYSIS AND RECOMMENDATIONS
- DRYWELL AGGREGATE MATERIAL MUST EXTEND TO WELL-DRAINING SOILS AS IDENTIFIED IN A GEOTECHNICAL ANALYSIS

6.4 Sand Filter

A sand filter is a filtering or infiltrating BMP that consists of a surcharge zone underlain by a sand bed with an underdrain system. During a storm, accumulated runoff collects in the surcharge zone and gradually infiltrates into the underlying sand bed, filling the void spaces of the sand. The underdrain gradually dewateres the sand bed and discharges the runoff to a nearby channel, swale, storm drain or detention basin. It is similar to a BMP designed for bioretention in that it utilizes filtering, but differs in that it is not specifically designed for vegetative growth. The absence of vegetation in a sand filter allows for active maintenance at the surface of the filter, (i.e., raking for removing a layer of sediment). For this reason, sand filter criteria allows for a larger contributing area and greater depth of storage. Sand filters can also be placed in a vault. Underground sand filters have additional requirements.

Design and construction detailing for sand filters are presented in the LID Implementation Manual. Included in **Figure 6.4-1** below are some key design guides for sand filters.

Figure 6.4-1. Design Criteria for Rain Gardens and Sand Filters

LOCATION	VOLUME	OVERFLOW	UNDERDRAINS
<ul style="list-style-type: none"> • Generally, Rain Gardens and Sand Filters shall be placed "offline" from the detention basin 	<ul style="list-style-type: none"> • Rain Gardens and Sand Filters are sized for the WQCV • Forebay shall be included and is to be sized for 1% of the WQCV and have a minimum depth of 12" • UD-BMP workbook may be utilized for sizing • Maximum depth is 12" for Rain Gardens 	<ul style="list-style-type: none"> • Area inlet or overflow required at the WQCV depth (12" above the rain garden finished grade surface) 	<ul style="list-style-type: none"> • Underdrain piping is required • Underdrain cleanouts are required for flushing and inspection

6.5 Linear Bioretention

Linear bioretention has low longitudinal slopes and broad cross-sections that convey flow in a slow and shallow manner, thereby facilitating sedimentation and filtering (straining) while limiting erosion. Berms or check dams may be incorporated into the facility to reduce velocities and encourage settling and infiltration. When using berms, an underdrain system should be provided. Linear bioretention is an integral part of the LID concept and may be used as an alternative to a curb and gutter system.

Design and construction detailing for linear bioretention systems are presented in the LID Implementation Manual in Appendix C. Included below are some additional design parameters that are specific to the City of Fort Collins.

Figure 6.5-1. Design Criteria for Linear Bioretention

SLOPES	GEOMETRY	2-YR STORM DESIGN
<ul style="list-style-type: none"> • Minimum longitudinal slope is 0.5% • Maximum longitudinal slope is 1.0% 	<ul style="list-style-type: none"> • Minimum bottom width is 24" • Maximum side slopes 4:1 	<ul style="list-style-type: none"> • Froude No. ≤ 0.5 • Velocity ≤ 1 fps • Depth ≤ 12"

6.6 Underground Filtration

Underground stormwater BMPs include proprietary and non-proprietary devices installed below ground that provide stormwater quality treatment via sedimentation, screening, filtration and other physical and chemical processes. When surface BMPs are found to be infeasible, underground BMPs may be the only available strategy for satisfying regulatory water quality and/or LID requirements, especially in highly built-up urban areas where water quality measures must be implemented as a part of a retrofit to meet regulatory requirements. The most common sites for underground BMPs are "ultra-urban" environments with significant space constraints. These could include downtown lot-line-to-lot-line development projects, transportation corridors, or small (less than 0.5 acre) redevelopment sites in urban areas.

Included below are some key design requirements for underground systems in Fort Collins. Additionally, design and construction detailing for underground detention and filtration systems are presented in the LID Implementation Manual in Appendix C, and underground detention design requirements are discussed in Chapter 5: Detention of this Manual.

Figure 6.6-1. Design Criteria for Underground LID

LOCATION	VOLUME
<ul style="list-style-type: none"> • Typically co-located with flood control detention structure • May be allowed within parking garages pending adequate access, maintenance and safety • Never allowed below buildings that include habitable space 	<ul style="list-style-type: none"> • Sized based on the 80th percentile storm using modified FAA method (for the sediment capture chamber) • Release rate is % of infiltration rate through subsurface • Major storm is required to bypass the water quality chamber • Proprietary software may be able to be utilized for volume sizing. This will be determined by FCU on a case-by-case basis. (If proprietary software is allowed, secondary hydraulic calculations may also be required for sizing verifications. • The total system is sized for the WQCV

Reference: See Chapter 6: Detention of this Manual, for discussion and design information on underground detention systems.

Underground detention and filtration basins that are designed using non-proprietary systems will be reviewed by FCU on a case-by-case basis. FCU does not want to discourage unique design ideas for LID systems; however, the designers are typically encouraged to utilize commonly utilized BMPs.

6.7 Vegetated Buffer

Vegetated buffers are densely vegetated strips of grass designed to accept sheet flow from upgradient development. The size of the buffer itself is relatively large compared to the impervious area that is draining onto it. Properly designed vegetated buffers play a key role in LID, enabling infiltration and slowing runoff while also providing filtration (straining) of sediment. Buffers differ from swales in that they are designed to accommodate overland sheet flow rather than concentrated or channelized flow. These are typically employed in a treatment train approach, as part of a larger water quality treatment system.

Figure 6.7-1. Design Criteria for Vegetated Buffers

DESIGN REQUIREMENTS	REQUIREMENTS FOR LID CREDIT
<ul style="list-style-type: none"> • Appropriate for sheet flow applications only • Level spreaders will be required where point discharges may occur • Minimum cross-slope is 2% and maximum cross-slope is 10% • Requires soil amendment and select vegetation to allow for 80% vegetative cover; does not require weekly maintenance and is not highly manicured with sod or mulch beds • Best suited as part of "treatment train" 	<ul style="list-style-type: none"> • In addition to the design requirements listed to the left, for vegetated buffers to serve as stand-alone LID treatment facility, the following parameters must also be met: • Cross-slopes are no greater than 5% • Buffer must be of an area equal to or greater than the impervious area running onto it (i.e. run-on ratio is 1:1 maximum) • Buffer must be a minimum of 14' wide (in the direction of flow) • Buffer area must be clearly delineated on the plans to eliminate site disturbance and compaction in the buffer area due to construction activities • Soils must be naturally suited for infiltration (i.e. type A or B soils)

Design and construction detailing for vegetated buffers are presented in the LID Implementation Manual in Appendix C.

6.8 Constructed Wetland Channel / Pond

A constructed wetland channel is a conveyance BMP that is built, in part, to enhance stormwater quality. Constructed wetland channels use dense vegetation to slow down runoff and allow time for both biological uptake and settling of sediment.

Constructed wetlands differ from natural wetlands, as they are artificial and are built to enhance stormwater quality. Do not use existing, natural or mitigated area wetlands to treat stormwater runoff. Stormwater must be treated prior to entering natural or existing wetlands and other environmentally sensitive areas. Allowing untreated stormwater to flow into existing wetlands will overload and degrade the quality of the wetland. Sometimes, small wetlands that exist along ephemeral drainageways on Colorado's high plains may be enlarged and incorporated into the constructed wetland system. Such action, however, requires the approval of federal and state regulators. Regulations intended to protect natural wetlands recognize a separate classification of wetlands constructed for water quality treatment. Such wetlands generally are not allowed to be used to mitigate the loss of natural wetlands but are allowed to be disturbed by maintenance activities. Therefore, the legal and regulatory status of maintaining a wetland constructed for the primary purpose of water quality enhancement is separate from the disturbance of a natural wetland. Nevertheless, any activity that disturbs a constructed wetland should be first cleared through the U.S. Army Corps of Engineers to ensure it is covered by some form of an individual, general, or nationwide 404 permit. Any creation of wetlands must also comply with Colorado law, including water rights laws.

Design and construction detailing for constructed wetlands are presented in the LID Implementation Manual in Appendix C.

6.9 Drainage Easements for LID

- Storage-based LID systems (bioretention, sand filters) are required to be placed in a drainage easement that is dedicated to the City
- Permeable pavers are required to be placed in a drainage easement when they are also used for quantity detention
- Extents of drainage easement need to encompass the entire footprint of the LID system

6.9.1 LID Systems in Other Utility Easements

- Generally, LID systems are discouraged from being located within utility easements behind the right-of-way; however, this will be considered on a case-by-case basis
- Conveyance-based LID systems (vegetated buffer) are allowed in utility easements that are located along the back of right-of-way
- Storage-based LID systems (bioretention, sand filters, permeable pavers) are not allowed to be placed in utility easements that are located along the back of right-of-way
- Pre-manufactured planters (for rain gardens) that can be temporarily relocated may be allowed in utility easements. This will be determined on a case-by-case basis by FCU staff.

6.9.2 LID Systems Not Accessible Via Easement

- All LID systems that may not be placed on the ground plane or those that are not accessible via easement or public right-of-way, will still be required to be accessed for inspection. A condition that allows access or entry to an area within the property or building (not accessible via easement) will be included in the Development Agreement for the project.

7.0 References

7.1 Extended Detention Basin (EDB) Fact Sheet T-5 from UDFCD Manual

DRAFT

Description

An extended detention basin (EDB) is a sedimentation basin designed to detain stormwater for many hours after storm runoff ends. This BMP is similar to a detention basin used for flood control, however; the EDB uses a much smaller outlet that extends the emptying time of the more frequently occurring runoff events to facilitate pollutant removal. The EDB's 40-hour drain time for the water quality capture volume (WQCV) is recommended to remove a significant portion of total suspended solids (TSS). Soluble pollutant removal is enhanced by providing a small wetland marsh or "micropool" at the outlet to promote biological uptake. The basins are sometimes called "dry ponds" because they are designed not to have a significant permanent pool of water remaining between storm runoff events.



Photograph EDB-1: This EDB includes a concrete trickle channel and a micropool with a concrete bottom and grouted boulder sideslopes. The vegetation growing in the sediment of the micropool adds to the natural look of this facility and ties into the surrounding landscape.

Site Selection

EDBs are well suited for watersheds with at least five impervious acres up to approximately one square mile of watershed. Smaller watersheds can result in an orifice size prone to clogging. Larger watersheds and watersheds with baseflows can complicate the design and reduce the level of treatment provided. EDBs are also well suited where flood detention is incorporated into the same basin. The depth of groundwater should be investigated. Groundwater depth should be 2 or more feet below the bottom of the basin in order to keep this area dry and maintainable.

Extended Detention Basin	
Functions	
LID/Volume Red.	Somewhat
WQCV Capture	Yes
WQCV+Flood Control	Yes
Fact Sheet Includes EURV Guidance	Yes
Typical Effectiveness for Targeted Pollutants³	
Sediment/Solids	Good
Nutrients	Moderate
Total Metals	Moderate
Bacteria	Poor
Other Considerations	
Life-cycle Costs ⁴	Moderate
³ Based primarily on data from the International Stormwater BMP Database (www.bmpdatabase.org). ⁴ Based primarily on BMP-REALCOST available at www.udfed.org . Analysis based on a single installation (not based on the maximum recommended watershed tributary to each BMP).	

Designing for Maintenance

Recommended maintenance practices for all BMPs are provided in the BMP Maintenance chapter of this manual. During design, the following should be considered to ensure ease of maintenance over the long-term:

- Always provide a micropool (see step 7).
- Provide a design slope of at least 3% in the vegetated bottom of the basin (either toward the trickle channel or toward the micropool). This will help maintain the appearance of the turf grass in the bottom of the basin and reduce the possibility of saturated areas that may produce unwanted species of vegetation and mosquito breeding conditions. Verify slopes during construction, prior to vegetation.
- Follow trash rack sizing recommendations to determine the minimum area for the trash rack (see design step 9).
- Provide adequate initial surcharge volume for frequent inundation (see design step 3).
- Provide stabilized access to the forebay, outlet, spillway, and micropool for maintenance purposes.
- Provide access to the well screen. The well screen requires maintenance more often than any other EDB component. Ensure that the screen can be reached from a point outside of the micropool. When the well screen is located inside the outlet structure, provide an access port within the trash rack or use a sloped trash rack that consists of bearing bars (not horizontal) that create openings no more than five inches clear.
- Provide a hard-bottom forebay that allows for removal of sediment.
- Where baseflows are anticipated, consider providing a flow-measuring device (e.g. weir or flume with staff gage and rating curve) at the forebay to assist with future modifications of the water quality plate. Typically, the baseflow will increase as the watershed develops. It is important that the water quality plate continue to function, passing the baseflow while draining the WQCV over approximately 40 hours. Measuring the actual baseflow can be helpful in determining if and when the orifice plate should be replaced.

Benefits

- The relatively simple design can make EDBs less expensive to construct than other BMPs, especially for larger basins.
- Maintenance requirements are straightforward.
- The facility can be designed for multiple uses.

Limitations

- Ponding time and depths may generate safety concerns.
- Best suited for tributary areas of 5 impervious acres or more. EDBs are not recommended for sites less than 2 impervious acres.
- Although ponds do not require more total area compared to other BMPs, they typically require a relatively large continuous area.

EDBs providing combined water quality and flood control functions can serve multiple uses such as playing fields or picnic areas. These uses are best located at higher elevation within the basin, above the WQCV pool level.

Design Procedure and Criteria

The following steps outline the design procedure and criteria for an EDB and Figure EDB-3 shows a typical configuration. UD-BMP, available at www.udfcd.org, is an Excel based workbook that can be used to perform some of the below calculations and ensure conformance to these criteria. UD-Detention, another workbook developed by UDFCD can be used to develop and route a storm hydrograph through an EDB and design the outlet structure.

1. **Basin Storage Volume:** Provide a design volume equal to the WQCV or the EURV. This volume begins at the lowest orifice in the outlet structure.
 - Determine the imperviousness of the watershed (or effective imperviousness where LID elements are used upstream).
 - Find the required storage volume. Determine the required WQCV or EURV (watershed inches of runoff) using Figure 3-2 located in Chapter 3 of this manual (for WQCV) or equations provided in the *Storage* chapter of Volume 2 (for EURV).
 - Calculate the design volume as follows:

For WQCV:

$$V = \left[\frac{WQCV}{12} \right] A \quad \text{Equation EDB-1}$$

For EURV:

$$V = \left[\frac{EURV}{12} \right] A \quad \text{Equation EDB-2}$$

Where:

V = design volume (acre ft)

A = watershed area tributary to the extended detention basin (acres)

2. **Basin Shape:** Always maximize the distance between the inlet and the outlet. It is best to have a basin length (measured along the flow path from inlet to outlet) to width ratio of at least 2:1. A longer flow path from inlet to outlet will minimize short circuiting and improve reduction of TSS. To achieve this ratio, it may be necessary to modify the inlet and outlet points through the use of pipes or swales.
3. **Basin Side Slopes:** Basin side slopes should be stable and gentle to facilitate maintenance and access. Slopes that are 4:1 or flatter should be used to allow for conventional maintenance equipment and for improved safety, maintenance, and aesthetics. Side slopes should be no steeper than 3:1. The use of walls is highly discouraged due to maintenance constraints.
4. **Inlet:** Dissipate flow energy at concentrated points of inflow. This will limit erosion and promote particle sedimentation. Inlets should be designed in accordance with UDFCD drop structure criteria for inlets above the invert of the forebay, impact basin outlet details for at grade inlets, or other types of energy dissipating structures.

5. **Forebay Design:** The forebay provides an opportunity for larger particles to settle out in an area that can be easily maintained. The length of the flow path through the forebay should be maximized, and the slope minimized to encourage settling. The appropriate size of the forebay may be as much a function of the level of development in the tributary area as it is a percentage of the WQCV. When portions of the watershed may remain disturbed for an extended period of time, the forebay size will need to be increased due to the potentially high sediment load. Refer to Table EDB-4 for a design criteria summary. When using this table, the designer should consider increasing the size of the forebay if the watershed is not fully developed.

The forebay outlet should be sized to release 2% of the undetained peak 100-year discharge. A soil riprap berm with 3:1 sideslopes (or flatter) and a pipe outlet or a concrete wall with a notch outlet should be constructed between the forebay and the main EDB. It is recommended that the berm/pipe configuration be reserved for watersheds in excess of 20 impervious acres to accommodate the minimum recommended pipe diameter of 8 inches. When using the berm/pipe configuration, round up to the nearest standard pipe size and use a minimum diameter of 8 inches. The floor of the forebay should be concrete or lined with grouted boulders to define sediment removal limits. With either configuration, soil riprap should also be provided on the downstream side of the forebay berm or wall if the downstream grade is lower than the top of the berm or wall. The forebay will overtop frequently so this protection is necessary for erosion control. All soil riprap in the area of the forebay should be seeded and erosion control fabric should be placed to retain the seed in this high flow area.

6. **Trickle Channel:** Convey low flows from the forebay to the micropool with a trickle channel. The trickle channel should have a minimum flow capacity equal to the maximum release from the forebay outlet.
- **Concrete Trickle Channels:** A concrete trickle channel will help to establish the bottom of the basin long-term and may also facilitate regular sediment removal. It can be a "V" shaped concrete drain pan or a concrete channel with curbs. A flat-bottom channel facilitates maintenance. A slope between 0.4% - 1% is recommended to encourage settling while reducing the potential for low points within the pan.
 - **Soft-bottom Trickle Channels:** When designed and maintained properly, soft-bottom trickle channels can allow for an attractive alternative to concrete. They can also improve water quality. However, they are not appropriate for all sites. Be aware, maintenance of soft bottom trickle channels requires mechanical removal of sediment and vegetation. Additionally, this option provides mosquito habitat. For this reason, UDFCD recommends that they be considered on a case-by-case basis and with the approval of the local jurisdiction. It is recommended that soft bottom trickle channels be designed with a consistent longitudinal slope from forebay to micropool and that they not meander. This geometry will allow for reconstruction of the original design when sediment removal in the trickle channel is necessary. The trickle channel may also be located along the toe of the slope if a straight channel is not desired. The recommended minimum depth of a soft bottom trickle channel is 1.5 feet. This depth will help limit potential wetland growth to the trickle channel, preserving the bottom of the basin.

Riprap and soil riprap lined trickle channels are not recommended due to past maintenance experiences, where the riprap was inadvertently removed along with the sediment during maintenance.

- Micropool and Outlet Structure:** Locate the outlet structure in the embankment of the EDB and provide a permanent micropool directly in front of the structure. Submerge the well screen to the bottom of the micropool. This will reduce clogging of the well screen because it allows water to flow through the well screen below the elevation of the lowest orifice even when the screen above the water surface is plugged. This will prevent shallow ponding in front of the structure, which provides a breeding ground for mosquitoes (large shallow puddles tend to produce more mosquitoes than a smaller, deeper permanent pond).

Micropool side slopes may be vertical walls or stabilized slopes of 3:1 (horizontal:vertical). For watersheds with less than 5 impervious acres, the micropool can be located inside the outlet structure (refer to Figures OS-7 and OS-8 provided in Fact Sheet T-12). The micropool should be at least 2.5 feet in depth with a minimum surface area of 10 square feet. The bottom should be concrete unless a baseflow is present or anticipated or if groundwater is anticipated. Riprap is not recommended because it complicates maintenance operations.

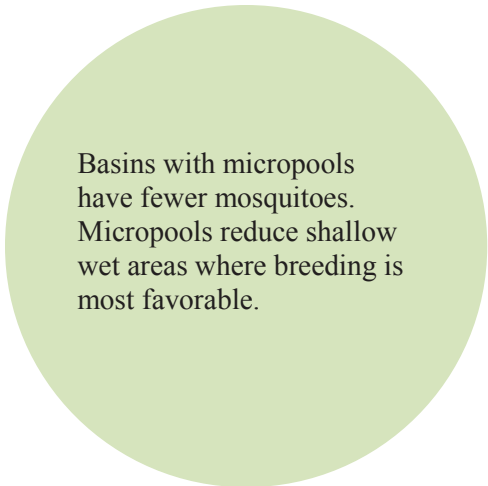

Where possible, place the outlet in an inconspicuous location as shown in Photo EDB-3. This urban EDB utilizes landscaped parking lot islands connected by a series of culverts (shown in Photo EDB-4) to provide the required water quality and flood control volumes.

The outlet should be designed to release the WQCV over a 40-hour period. Draining a volume of water over a specified time can be done through an orifice plate as detailed in Fact Sheet T-12. Use reservoir routing calculations as discussed in the *Storage* Chapter of Volume 2 to assist in the design. Two workbooks tools have been developed by UDFCD for this purpose, UD-FSD and UD-Detention. Both are available at www.udfcd.org. UD-FSD is recommended for a typical EDB full spectrum detention design. UD-Detention uses the same methodology and can be used for a full spectrum detention basin or a WQCV only design. It also allows for a wider range of outlet controls should the user want to specify something beyond what is shown in Fact Sheet T-12.

Refer to BMP Fact Sheet T-12 for schematics pertaining to structure geometry, grates, trash racks, orifice plate, and all other necessary components.

The outlet may have flared or parallel wing walls as shown in Figures EDB-1 and EDB-2, respectively. Either configuration should be recessed into the embankment to minimize its profile. Additionally, the trash rack should be sloped with the basin side-slopes.

8. **Initial Surcharge Volume:** Providing a surcharge volume above the micropool for frequently occurring runoff minimizes standing water and sediment deposition in the remainder of the basin. This is critical to turf maintenance and mosquito abatement in the basin bottom. The initial surcharge volume is not provided in the micropool nor does it include the micropool volume. It is the available storage volume that begins at the water surface elevation of the micropool and extends upward to a grade break within the basin (typically the invert of the trickle channel).



Photograph EDB-2. The initial surcharge volume of this EDB is contained within the boulders that surround the micropool.



Photograph EDB-3. Although walls may complicate maintenance access, this outlet structure is relatively hidden from public view. This photo was taken shortly following a storm event.

The area of the initial surcharge volume, when full, is typically the same or slightly larger than that of the micropool. The initial surcharge volume should have a depth of at least 4 inches. For watersheds of at least 5 impervious acres, the initial surcharge volume should also be at least 0.3% of the WQCV. The initial surcharge volume is considered a part of the WQCV and does not need to be provided in addition to the WQCV. It is recommended that this area be shown on the grading plan or in a profile for the EDB. When baseflows are anticipated, it is recommended that the initial surcharge volume be increased. See the inset on page EDB-9 for additional guidelines for designing for baseflows.



Photograph EDB-4. A series of landscape islands connected by culverts provide water quality and flood control for this site.

9. **Trash Rack:** Provide a trash rack (or screen) of sufficient size at the outlet to provide hydraulic capacity while the rack is partially clogged. Openings should be small enough to limit clogging of the individual orifices. Size any overflow safety grate so it does not interfere with the hydraulic capacity of the outlet pipe. See BMP Fact Sheet T-12 for detailed trash rack and safety grate design guidance.

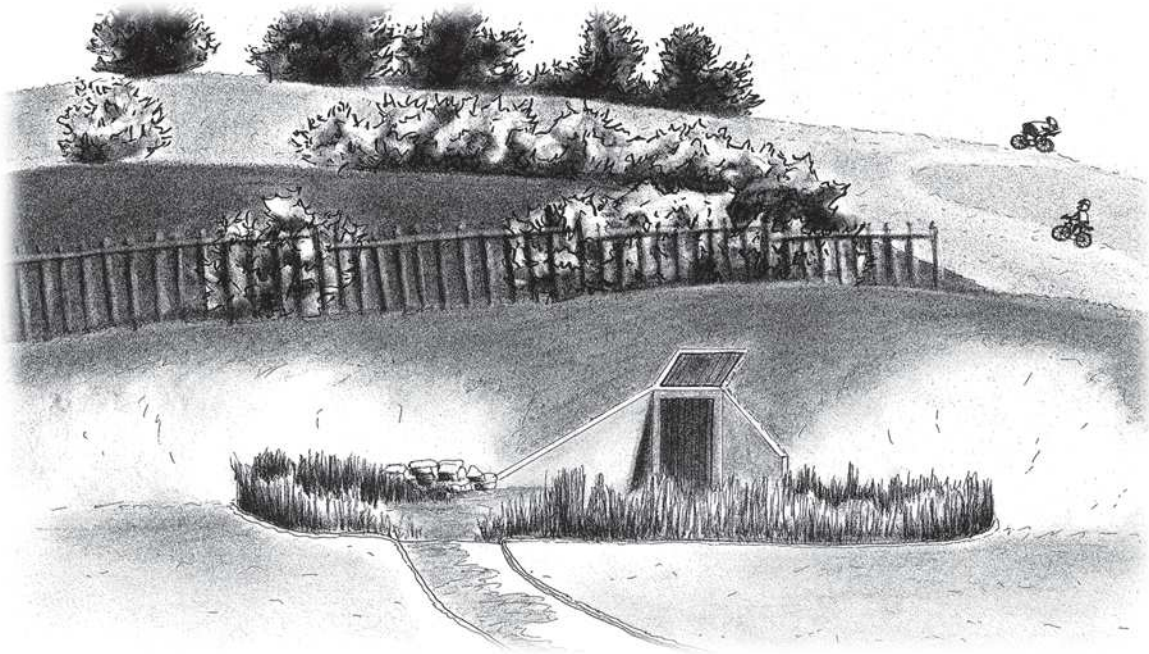

Figure EDB-1. Flared wall outlet structure configuration. Graphic by Adia Davis.

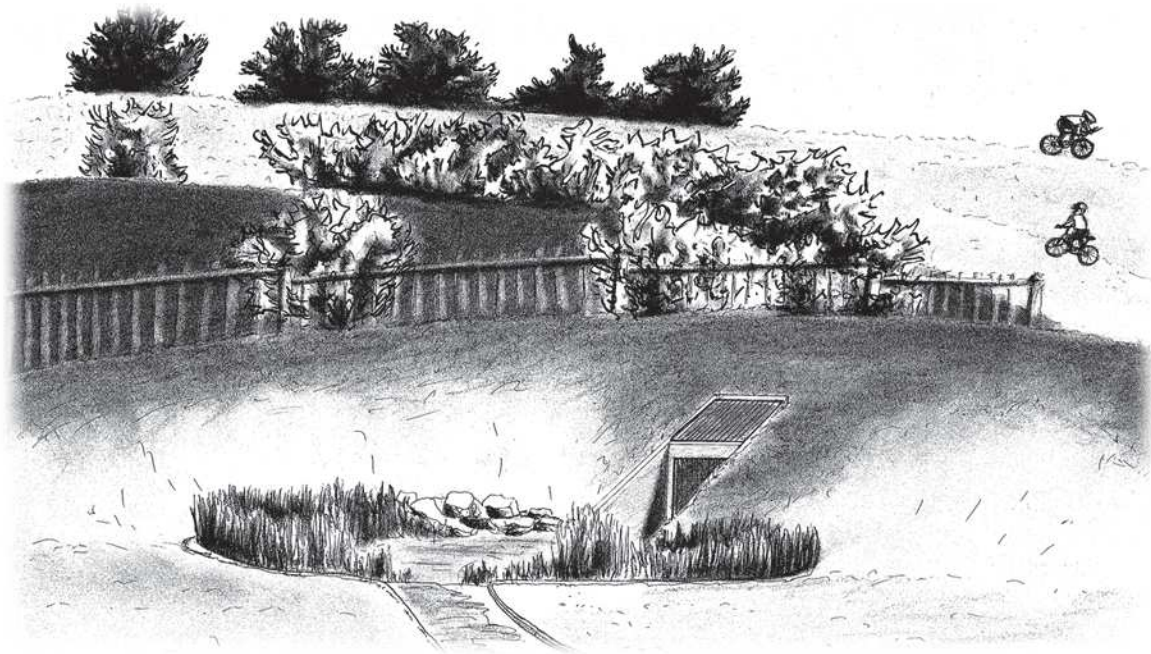

Figure EDB-2. Parallel wall outlet structure configuration. Graphic by Adia Davis.

10. **Overflow Embankment:** Design the embankment to withstand the 100-year storm at a minimum. If the embankment falls under the jurisdiction of the State Engineer's Office, it must be designed to meet the requirements of the State Engineer's Office. The overflow should be located at a point where waters can best be conveyed downstream. Slopes that are 4:1 or flatter should be used to allow for conventional maintenance equipment and for improved safety, maintenance, and aesthetics. Side slopes should be no steeper than 3:1 and should be planted with turf forming grasses. Poorly compacted native soils should be excavated and replaced. Embankment soils should be compacted to 95% of maximum dry density for ASTM D698 (Standard Proctor) or 90% for ASTM D1557 (Modified Proctor). Spillway structures and overflows should be designed in accordance with the *Storage* Chapter of Volume 2 as well as any local drainage criteria. Buried soil riprap or reinforced turf mats installed per manufacturer's recommendations can provide an attractive and less expensive alternative to concrete.
11. **Vegetation:** Vegetation provides erosion control and sediment entrapment. Basin bottom, berms, and side slopes should be planted with turf grass, which is a general term for any grasses that will form a turf or mat, as opposed to bunch grass which will grow in clumplike fashion. Xeric grasses with temporary irrigation are recommended to reduce maintenance requirements, including maintenance of the irrigation system as well as frequency of mowing. Where possible, place irrigation heads outside the basin bottom because irrigation heads in an EDB can become buried with sediment over time.
12. **Access:** Provide appropriate maintenance access to the forebay and outlet works. For larger basins, this means stabilized access for maintenance vehicles. If stabilized access is not provided, the maintenance plan should provide detail, including recommended equipment, on how sediment and trash will be removed from the outlet structure and micropool. Some communities may require

Designing for Baseflows

Baseflows should be anticipated for large tributary areas and can be accommodated in a variety of ways. Consider the following:

- If water rights are available, consider alternate BMPs such as a constructed wetland pond or retention pond.
- Anticipate future modifications to the outlet structure. Following construction, baseflows should be monitored periodically. Intermittent flows can become perennial and perennial flows can increase over time. It may be determined that outlet modifications are necessary long after construction of the BMP is complete.
- Design foundation drains and other groundwater drains to bypass the water quality plate directing these drains to a conveyance element downstream of the EDB. This will reduce baseflows and help preserve storage for the WQCV.
- When the basin is fully developed and an existing baseflow can be approximated prior to design, the water quality orifices should be increased to drain the WQCV in 40 hours while also draining the baseflow. This requires reservoir routing using an inflow hydrograph that includes the baseflow. The *UD-Detention* workbook available at www.udfcd.org may be used for this purpose.
- Increase the initial surcharge volume of the pond to provide some flexibility when baseflows are known or anticipated. Baseflows are difficult to approximate and will continue to increase as the watershed develops. Increasing the initial surcharge volume will accommodate a broader range of flows.

vehicle access to the bottom of the basin regardless of the size of the watershed. Grades should not exceed 10% for haul road surfaces and 20% for skid-loader and backhoe access. Stabilized access includes concrete, articulated concrete block, concrete grid pavement, or reinforced grass pavement. The recommended cross slope is 2%.

Aesthetic Design

Since all land owners and managers wish to use land in the most efficient manner possible, it is important that EDBs become part of a multi-use system. This encourages the design of EDBs as an aesthetic part of a naturalized environment or to include passive and/or active open space. Within each scenario, the EDB can begin to define itself as more than just a drainage facility. When this happens, the basin becomes a public amenity. This combination of public amenity and drainage facility is of much greater value to a landowner. Softened and varied slopes, interspersed irrigated fields, planting areas and wetlands can all be part of an EDB.

The design should be aesthetic whether it is considered to be an architectural or naturalized basin. Architectural basins incorporate design borrowed or reflective of the surrounding architecture or urban forms. An architectural basin is intended to appear as part of the built environment, rather than hiding the cues that identify it as a stormwater structure. A naturalized basin is designed to appear as though it is a natural part of the landscape. This section provides suggestions for designing a naturalized basin. The built environment, in contrast to the natural environment, does not typically contain the randomness of form inherent in nature. Constructed slopes typically remain consistent, as do slope transitions. Even dissipation structures are usually a hard form and have edges seldom seen in nature. If the EDB is to appear as though it is a natural part of the landscape, it is important to minimize shapes that provide visual cues indicating the presence of a drainage structure. For example, the side sides should be shaped more naturally and with varying slopes for a naturalized basin.

Suggested Methods for a Naturalized Basin

- Create a flowing form that looks like it was shaped by water.
- Extend one side of the basin higher than the other. This may require a berm.
- Shape the bottom of the basin differently than the top.
- Slope of one side of the basin more mildly than the opposing side.
- Vary slope transitions both at the top of the bank and at the toe.
- Use a soft-surface trickle channel if appropriate and approved.
- When using rock for energy dissipation, the rock should graduate away from the area of hard edge into the surrounding landscape. Other non-functional matching rock should occur in other areas of the basin to prevent the actual energy dissipation from appearing out of context.
- Design ground cover to reflect the type of water regime expected for their location within the basin.

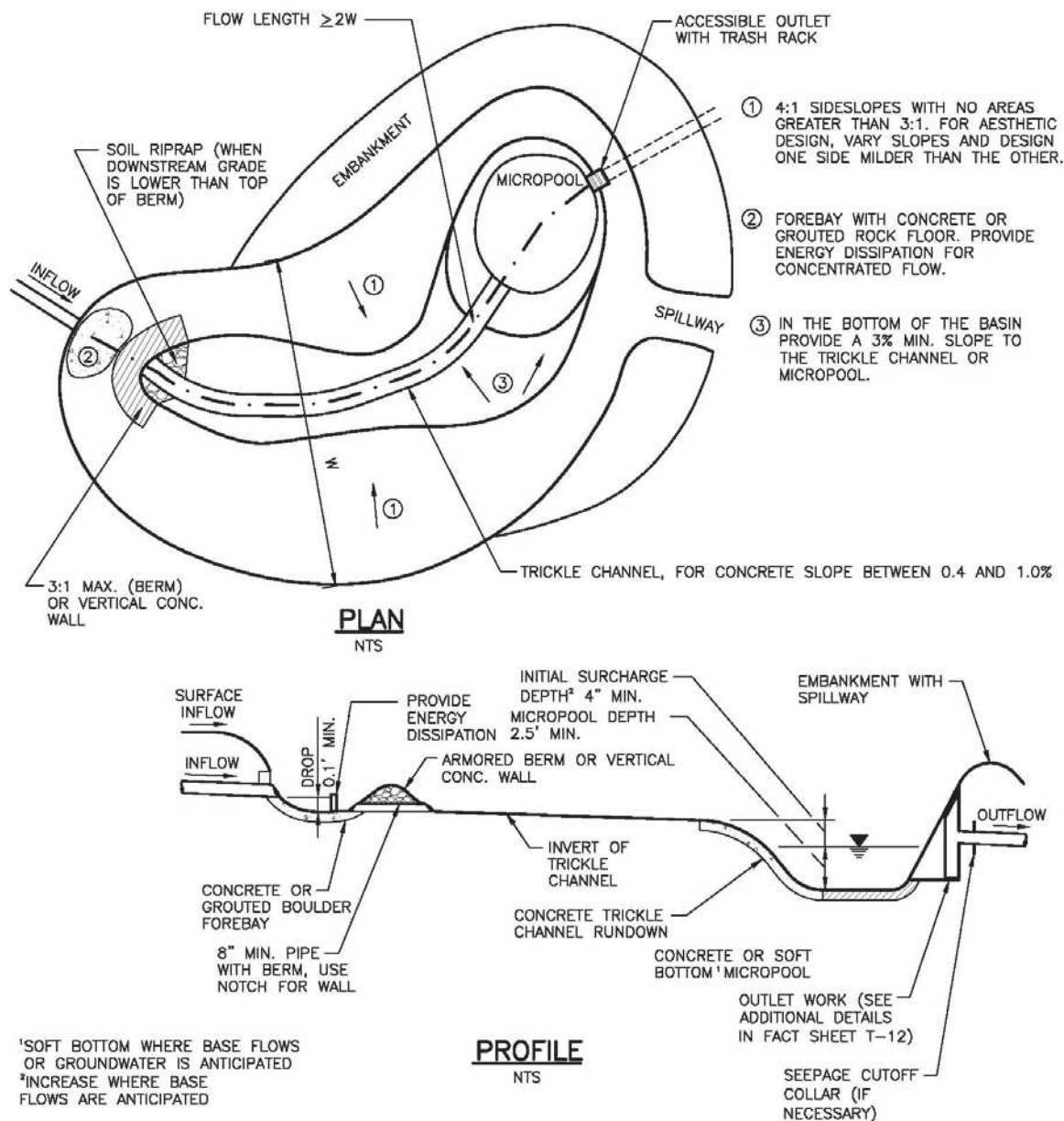

**FIGURE EDB-3
EXTENDED DETENTION BASIN**

Figure EDB-3. Extended Detention Basin (EDB) Plan and Profile

Additional Details are provided in BMP Fact Sheet T-12. This includes outlet structure details including orifice plates and trash racks.

Table EDB-4. EDB component criteria

	On-Site EDBs for Watersheds up to 1 Impervious Acre ¹	EDBs with Watersheds between 1 and 2 Impervious Acres ¹	EDBs with Watersheds up to 5 Impervious Acres	EDBs with Watersheds over 5 Impervious Acres	EDBs with Watersheds over 20 Impervious Acres
Forebay Release and Configuration	EDBs should not be used for watersheds with less than 1 impervious acre.	Release 2% of the undetained 100-year peak discharge by way of a wall/notch configuration	Release 2% of the undetained 100-year peak discharge by way of a wall/notch configuration	Release 2% of the undetained 100-year peak discharge by way of a wall/notch configuration	Release 2% of the undetained 100-year peak discharge by way of a wall/notch or berm/pipe ² configuration
Minimum Forebay Volume		1% of the WQCV	2% of the WQCV	3% of the WQCV	3% of the WQCV
Maximum Forebay Depth		12 inches	18 inches	18 inches	30 inches
Trickle Channel Capacity		≥ the maximum possible forebay outlet capacity	≥ the maximum possible forebay outlet capacity	≥ the maximum possible forebay outlet capacity	≥ the maximum possible forebay outlet capacity
Micropool		Area ≥ 10 ft ²	Area ≥ 10 ft ²	Area ≥ 10 ft ²	Area ≥ 10 ft ²
Initial Surge Volume		Depth ≥ 4 inches	Depth ≥ 4 inches	Depth ≥ 4 in. Volume ≥ 0.3% WQCV	Depth ≥ 4 in. Volume ≥ 0.3% WQCV

¹ EDBs are not recommended for sites with less than 2 impervious acres. Consider a sand filter or rain garden.

² Round up to the first standard pipe size (minimum 8 inches).

7.2 Outlet Structures Fact Sheet T-12 from UDFCD Manual

DRAFT

Description

This section provides guidance and details for outlet structures for the use primarily with BMPs utilizing sedimentation, (i.e., extended detention basins, retention ponds and constructed wetland ponds). The information provided in this section includes guidance for different size watersheds as well as for incorporating full spectrum detention as described in the *Storage* chapter of Volume 2.

The details contained in this Fact Sheet are intended to provide a starting point for design. UDFCD recommends that design details for outlet structures be specific for each site with structural details drawn to scale. The details provided in this Fact Sheet are not intended to be used without modification or additional detail.



Photograph OS-1. Although each site is different, most sedimentation BMPs have similar outlet structures. Each structure should include a partially submerged orifice plate with a screen (or grate) protecting the orifice plate from clogging, and an overflow weir for flows exceeding the WQCV or excess urban runoff volume (EURV), when full spectrum detention is used.

Outlet Design

Large Watershed Considerations

UDFCD recommends that water quality treatment be provided close to the pollutant source. This is a fundamental concept of Low Impact Development (LID). Although flood control facilities, including full spectrum detention facilities, have been shown to be very effective for watersheds exceeding one square mile, this is not the case for water quality facilities. One reason for this is that the baseflow associated with a larger watershed will vary and can be difficult to estimate. The orifice plate should be designed to pass the baseflow while detaining the water quality capture volume (WQCV) for approximately 40 hours. When the baseflow is overestimated, the WQCV is not detained for the recommended time, passing through without treatment. When the baseflow is underestimated, the elevation of the permanent pool will be higher than designed, causing maintenance issues as well as reducing the volume available for detention of the WQCV, which also allows for a portion of this volume to pass through without treatment. For this reason, UDFCD recommends that facilities designed for both water quality and flood control be limited, where possible, to watersheds without a baseflow. The maximum recommended watershed for combined facilities is one square mile. Additional discussion on designing for baseflows is provided in the EDB BMP Fact Sheet (T-5).

Designing for Maintenance

Rather than using the minimum criteria, consider maximizing the width of the trash rack to the geometry of the outlet. This will reduce clogging and frequency of maintenance. Reduced clogging in EDB outlet structures will preserve the initial surcharge volume thus reducing frequency of inundation in the bottom of the basin. This will benefit the grasses and reduce long-term EDB maintenance requirements (including sediment removal in the grassed area) and may reduce the life-cycle cost of the BMP.

Orifice Plates, Trash Racks, and Safety Grates

An orifice plate is used to release the WQCV slowly over 40 hours. For full spectrum detention, the orifice plate is extended to drain a larger volume, the EURV, over approximately 72 hours. The figures and tables in this section provide recommendations for orifice configurations and trash rack type and size. Guidance is provided for plates using both circular and rectangular orifices.

Orifice Sizing

Follow the design steps included in the BMP Fact Sheet for the appropriate BMP. The UD-Detention workbook, available at www.udfcd.org, can be used to route flows and calculate the required orifice sizes. UDFCD recommends a total of three orifices to maximize the orifice size and avoid clogging of the orifice plate. A detail showing the recommended orifice configuration is provided in Figure OS-4.

Trash Rack Sizing

Once the size of the orifice has been determined, this information, along with the total orifice area in the water quality plate, is used to determine the total open area of the grate. See Figure OS-1 and use the dashed line to size the trash rack. Include the portion of the trash rack that is inundated by the micropool in total open area of the grate.

Be aware, Figures OS-5, OS-6, OS-7, and OS-8 dimension the minimum width clear for the trash rack frame. It is also important to provide adequate width for attachment to the outlet structure (see Photos OS-2 and OS-3). Also, consider maximizing the width of the trash rack to the geometry of the outlet. This will reduce clogging and maintenance requirements associated with cleaning the trash rack. This Fact Sheet also includes recommendations for the thickness of the steel water quality plate (see Table OS-2).



Photograph OS-2. This trash rack could not be properly



Photograph OS-3. Trash rack after repair.

Safety Grates

Safety grates are intended to keep people and animals from inadvertently entering a storm drain. They are sometimes required even when debris entering a storm drain is not a concern. The grate on top of the outlet drop box is considered a safety grate and should be designed accordingly. The danger associated with outlet structures is the potential associated with pinning a person or animal to unexposed outlet pipe or grate. See the *Culverts and Bridges* chapter of Volume 2 of this manual for design criteria related to safety grates.

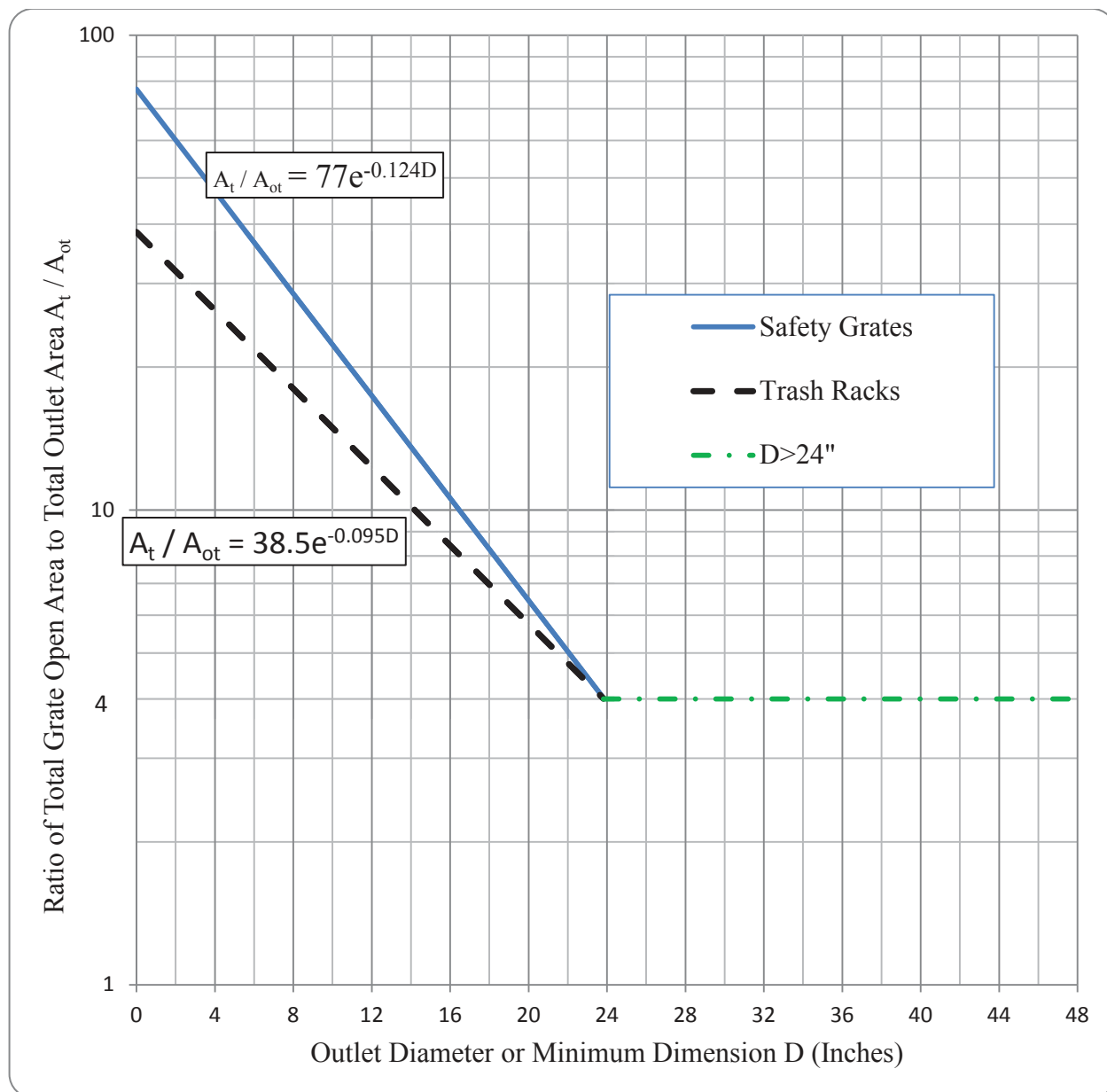

Figure OS-1. Trash Rack Sizing

Outlet Geometry

Outlets for small watersheds will typically be sized for maintenance operations while the geometry of outlets for larger watersheds may be determined based on the required size of the trash rack. For all watershed sizes, the outlet should be set back into the embankment of the pond to better allow access to the structure. This also provides a more attractive BMP. For larger watersheds, this will require wing walls. Wing walls are frequently cast-in-place concrete, although other materials, such as grouted boulders, may be used where appropriate. Consider safety, aesthetics, and maintenance when selecting materials and determining the geometry. A safety rail should be included for vertical drops of 3 feet or more. Depending on the location of the structure in relation to pedestrian trails, safety rails may also be required for lesser drops. Stepped grouted boulders can be used to reduce the height of vertical drops.

As shown in Figures EDB-1 and EDB-2 provided in BMP Fact Sheet T-5, wing walls can be flared or parallel. There are advantages to both configurations. Parallel wing walls may be more aesthetic; however, depending on the geometry of the pond, may limit accessibility to the trash rack. Flared wing walls can call attention to the structure but provide better accessibility and sometimes a vertical barrier from the micropool of an EDB, which can increase safety of the structure. Parallel walls can also be used with a second trash rack that is secured flush with the top of the wall as shown in Photo OS-4. This eliminates the need for a safety rail and may provide additional protection from clogging; however, it creates a maintenance issue by restricting access to the water quality screen. The rack shown in Photo OS-4 was modified after construction due to this problem.



Photograph OS-4. Maintenance access to the water quality trash rack was compromised by the location of a secondary trash rack on this outlet. This may have been included as a safety rack or as additional protection from clogging. The owner modified the structure for better access. A safety rail would have been a better solution.



Photograph OS-5. Interruptions in the horizontal members of this trash rack and the spacing of the vertical members allow easier access to clean the water quality grate. A raking tool can be used to scrape the water quality trash rack.

Micropools within the Outlet Structure

The micropool of an EDB may be placed inside the structure when desired. This is becoming increasingly common for smaller watersheds and near airfields where large bird populations can be problematic. When designing this type of structure, consider maintenance of the water quality trash rack. The secondary trash rack should be designed to allow maintenance of the water quality trash rack similar to that shown in Photo OS-5. This concept can easily be incorporated into smaller outlet structures (see Figures OS-7 and OS-8 for details).

Outlet Structure Details

A number of details are presented in this section to assist designers with detailing outlet structures. Table OS-1 provides a list of details available at www.udfcd.org. These details are not intended to be used in construction plans without proper modifications as indicated in this table.

Table OS-1. Summary of Outlet Structure Details and Use

Figure	Detail	Use of Detail
OS-2	Typical outlet structure for full spectrum detention	Conceptual.
OS-3	Typical outlet structure for WQCV treatment and attenuation	Conceptual.
OS-4	Orifice plate and trash rack detail and notes	Outlet section. Modify per true structure geometry and concrete reinforcement. Modify notes per actual design.
OS-5	Typical outlet structure with well screen trash rack	Outlet sections. Modify per true structure geometry and concrete reinforcement. Add additional sections and detailing as necessary. Modify notes per actual design.
OS-6	Typical outlet structure with bar grate trash rack	Outlet sections. Modify per true structure geometry and concrete reinforcement. Add additional sections and detailing as necessary. Modify notes per actual design.
OS-7	Full spectrum detention outlet structure for 5-acre impervious area or less	Outlet profile and section. Modify per true EURV elevation and concrete reinforcement. Add additional sections and detailing as necessary.
OS-8	WQCV outlet structure for 5-acre impervious area or less	Outlet sections. Modify per true WQCV elevation and concrete reinforcement. Add additional sections and detailing as necessary.

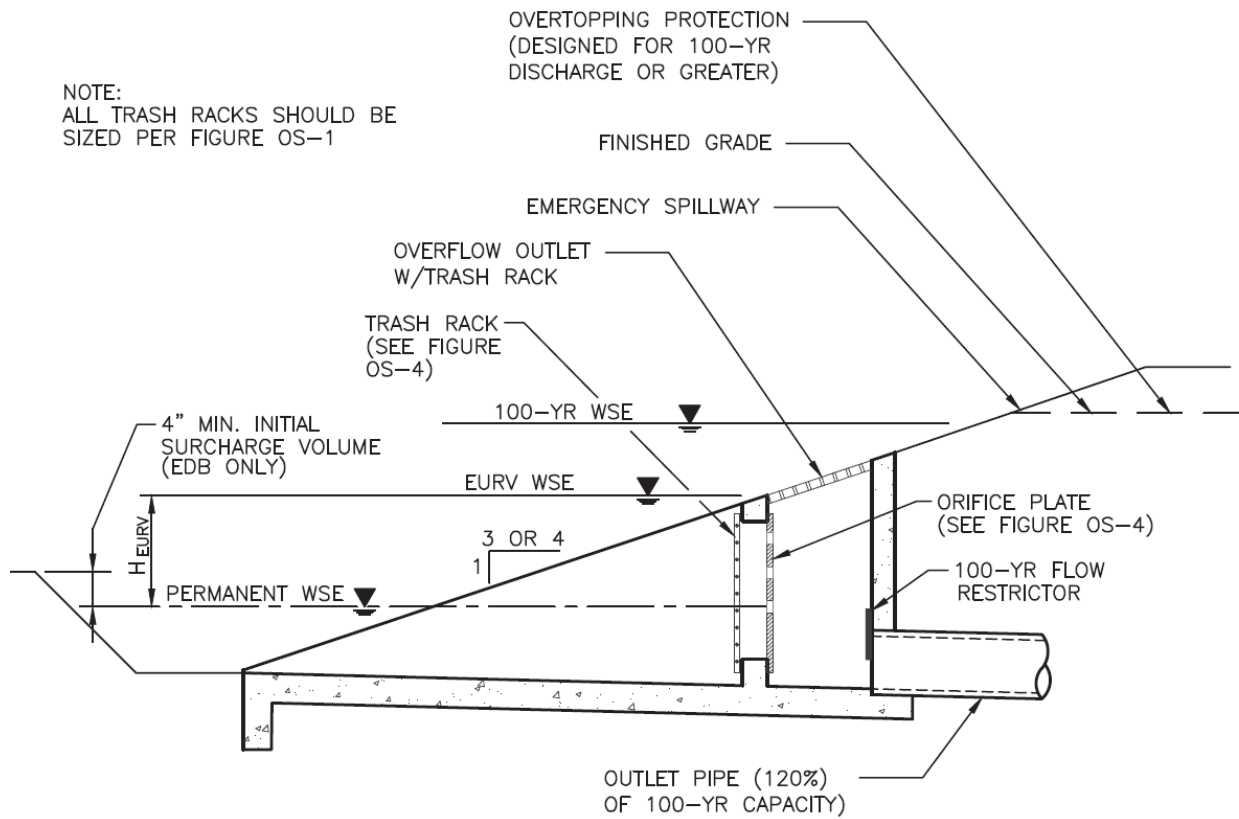

Figure OS-2. Typical outlet structure for full spectrum detention

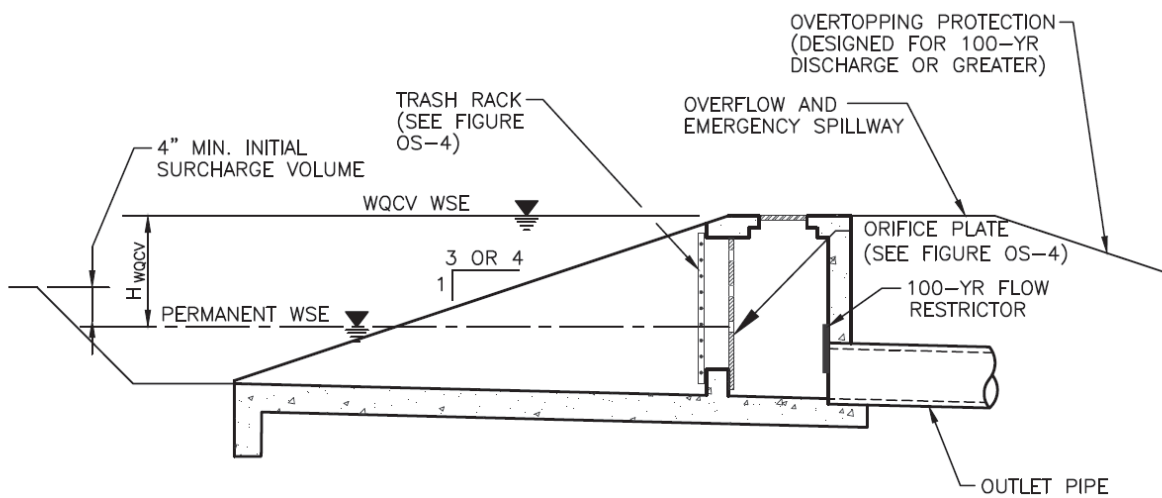
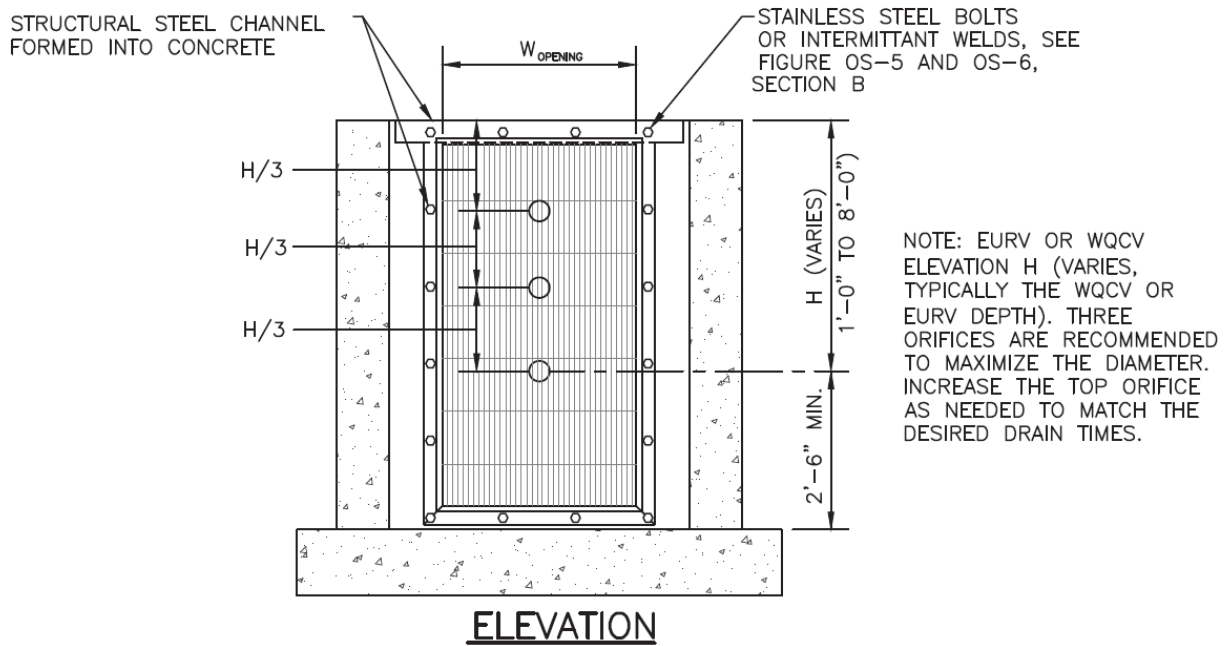

Figure OS-3. Typical outlet structure for WQCV treatment and attenuation



ORIFICE PLATE NOTES:

1. PROVIDE CONTINUOUS NEOPRENE GASKET MATERIAL BETWEEN THE ORIFICE PLATE AND CONCRETE.
2. BOLT PLATE TO CONCRETE 12" MAX. ON CENTER. SEE TABLE OS-2 FOR PLATE THICKNESS.

EURV AND WQCV TRASH RACKS:

1. WELL-SCREEN TRASH RACKS SHALL BE STAINLESS STEEL AND SHALL BE ATTACHED BY INTERMITTENT WELDS ALONG THE EDGE OF THE MOUNTING FRAME.
2. BAR GATE TRASH RACKS SHALL BE ALUMINUM AND SHALL BE BOLTED USING STAINLESS STEEL HARDWARE.
3. TRASH RACK OPEN AREAS ARE FOR SPECIFIED TRASH RACK MATERIALS. TOTAL TRASH RACK SIZE MAY NEED TO BE ADJUSTED FOR MATERIALS HAVING DIFFERENT OPEN AREA/GROSS AREA RATIO (R VALUE).
4. STRUCTURAL DESIGN OF TRASH RACKS SHALL BE BASED ON FULL HYDROSTATIC HEAD WITH ZERO HEAD DOWNSTREAM OF THE RACK.

OVERFLOW SAFETY GRATES:

1. ALL SAFETY GRATES SHALL BE MOUNTED USING STAINLESS STEEL HARDWARE AND PROVIDED WITH HINGED AND LOCKABLE OR BOLTABLE ACCESS PANELS.
2. SAFETY GRATES SHALL BE STAINLESS STEEL, ALUMINUM, OR STEEL. STEEL GRATES SHALL BE HOT DIP GALVANIZED AND MAY BE HOT POWDER COATED AFTER GALVANIZING.
3. SAFETY GRATES SHALL BE DESIGNED SUCH THAT THE DIAGONAL DIMENSION OF EACH OPENING IS SMALLER THAN THE DIAMETER OF THE OUTLET PIPE.
4. STRUCTURAL DESIGN OF SAFETY GRATES SHALL BE BASED ON FULL HYDROSTATIC HEAD WITH ZERO HEAD DOWNSTREAM OF THE RACK.

Figure OS-4. Orifice plate and trash rack detail and notes

Table OS-2. Thickness of steel water quality plate

Steel plate thickness (in inches) based on design depth and span of plate											
Head (feet)											
		3	4	5	6	7	8	9	10	11	12
Span (feet)	1	0.1875	0.1875	0.1875	0.1875	0.1875	0.1875	0.1875	0.1875	0.1875	0.1875
	2	0.1875	0.2500	0.2500	0.2500	0.2500	0.2500	0.2500	0.2500	0.2500	0.2500
	3	0.2500	0.2500	0.3750	0.3750	0.3750	0.3750	0.3750	0.3750	0.3750	0.5000
	4	0.2500	0.3750	0.3750	0.3750	0.3750	0.5000	0.5000	0.5000	0.5000	0.5000

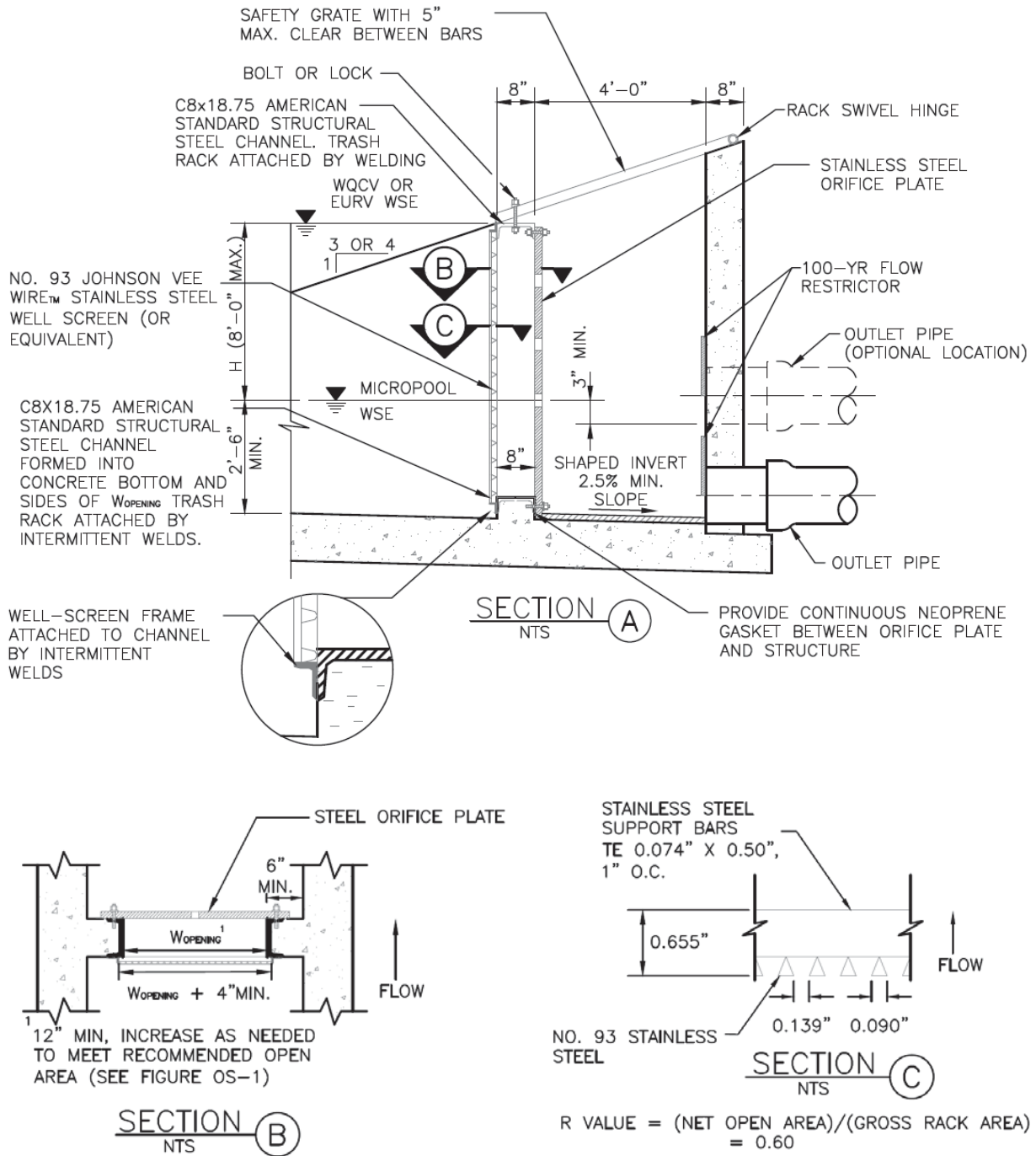

Figure OS-5. Typical outlet structure with well screen trash rack

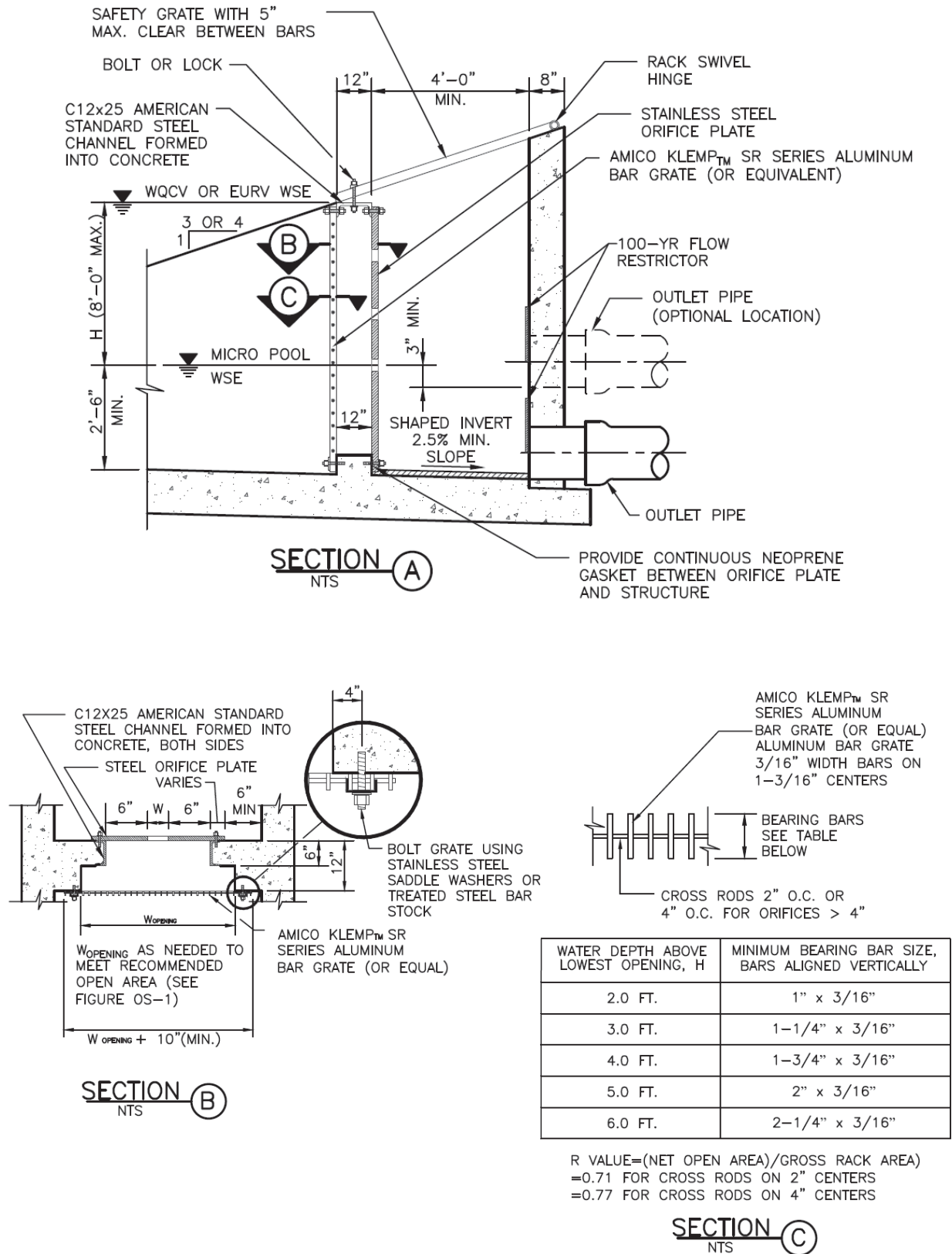

Figure OS-6. Typical outlet structure with bar grate trash rack

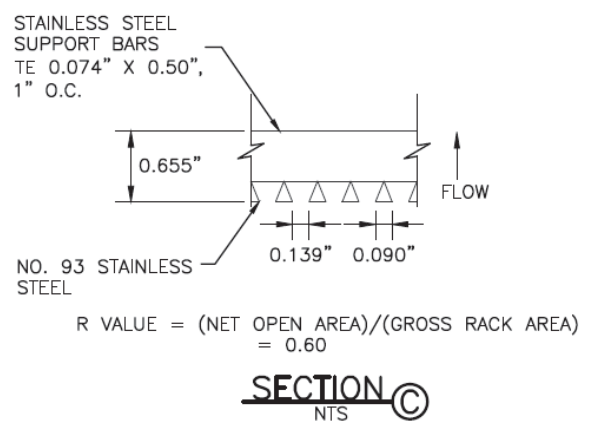
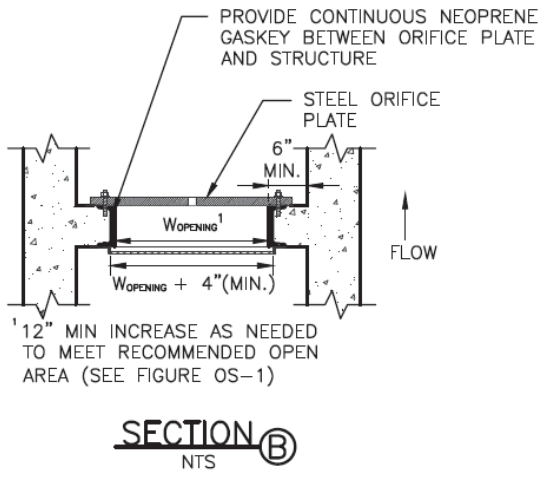
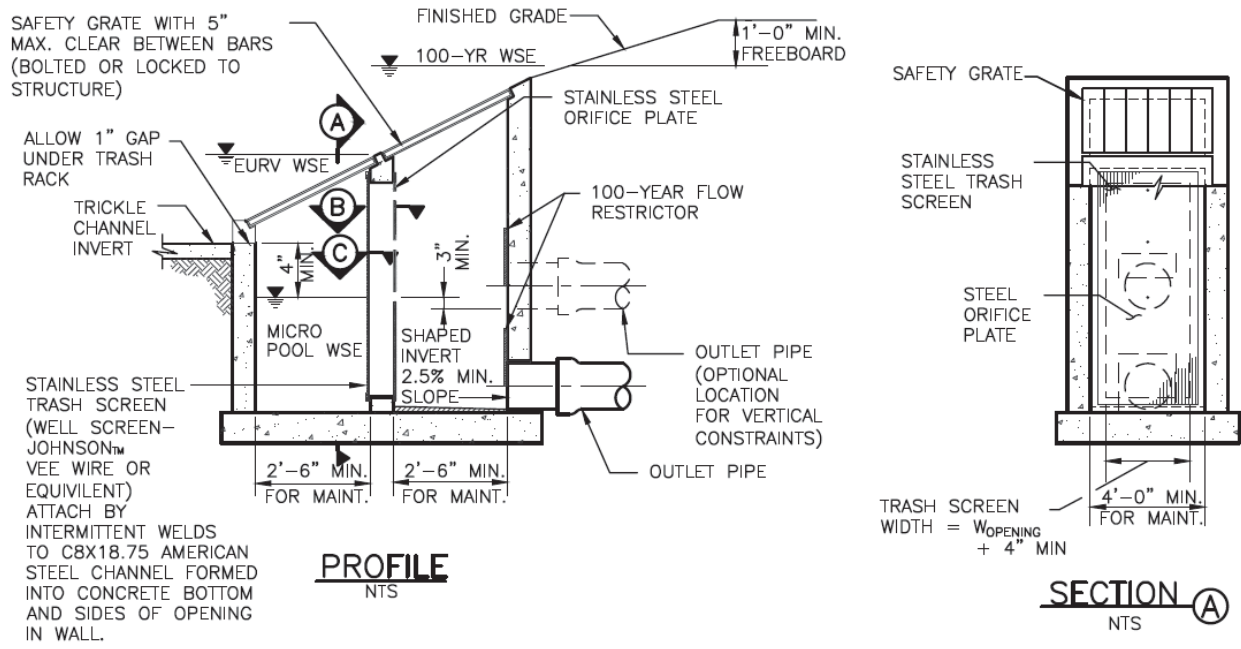

Figure OS-7. Full spectrum detention outlet structure for 5-acre impervious area or less

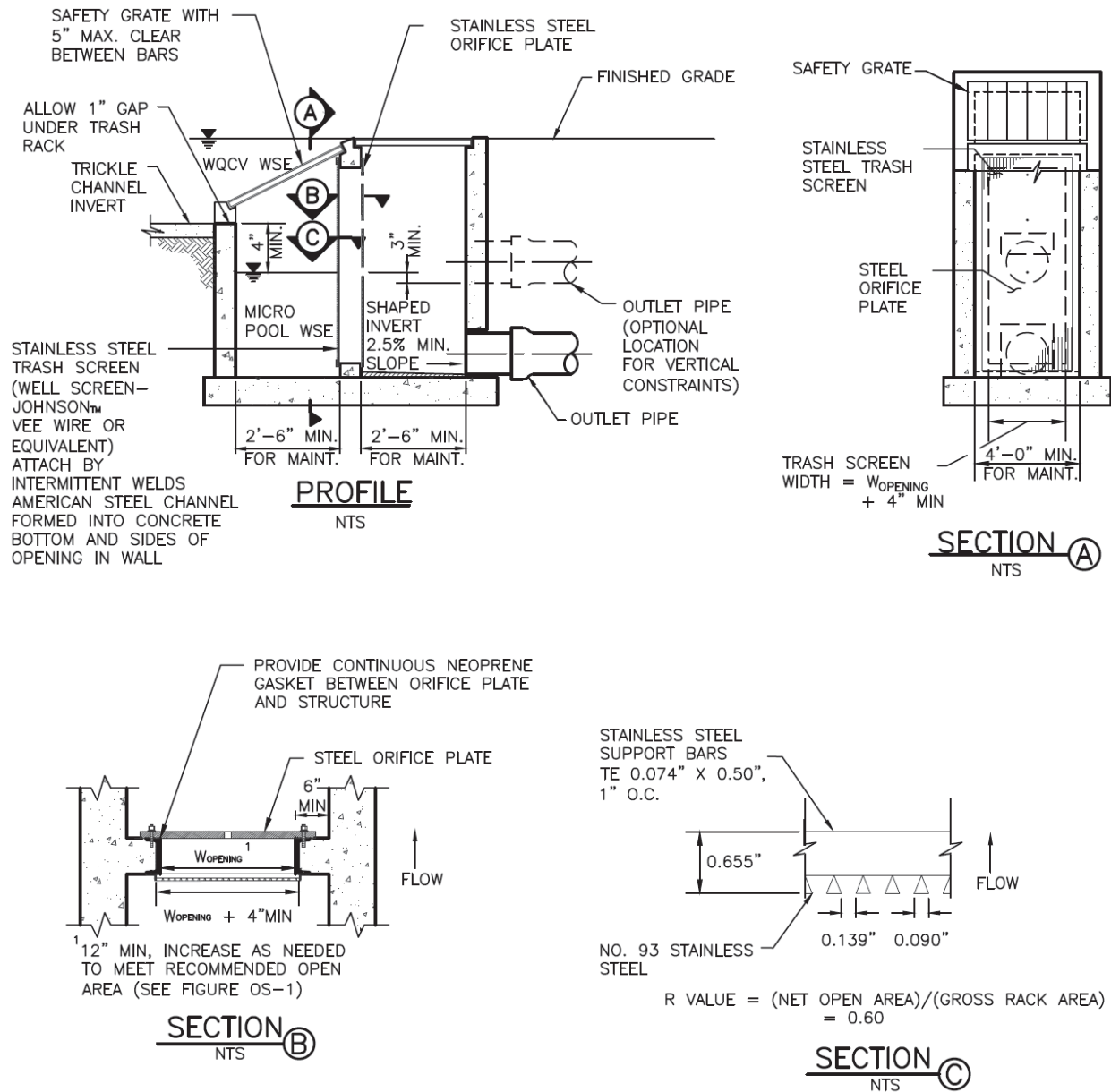

FIGURE OS-8

Figure OS-8. WQCV outlet structure for 5-acre impervious area or less

Chapter 8: Grading

Contents

- 1.0 Overview 1
- 2.0 Site Grading Design 1
 - 2.1 Single Family Lot Grading..... 1
 - 2.2 Surface Grading..... 6
 - 2.3 Channel/Swale Grading..... 6
- 3.0 Detention Basin Grading Design 8
 - 3.1 Geometry of Stormwater Detention Facilities..... 8
 - 3.2 Retaining Walls and Safety Railings 10
 - 3.3 Trickle Channels 11
 - 3.4 Freeboard..... 11
 - 3.5 Spillway 12
- 4.0 Landscaping..... 14
- 5.0 Drainage Easements 14

1.0 Overview

This Chapter provides requirements and guidance on site grading parameters to be incorporated into overall site design and for more specific locations such as single-family lots and detention basins. The requirements set forth in this Chapter shall be adhered to unless there are more stringent parameters set forth in a geotechnical report for the development site.

2.0 Site Grading Design

2.1 Single Family Lot Grading

Single family lot grading design requirements include the following:

- Positive drainage away from structures:** Grading design must show that there is positive grade away from all structures. More specifically, there must be a minimum grade of five percent (5%) away from a structure within the first five feet (5') (10' preferred), or as specified in the geotechnical report for the site, whichever is greater.
- Top of foundation elevation:** Grading design must show the top of foundation elevation for a structure and it must be set a minimum of six inches (6") above the highest grade surrounding the structure, or as specified in the geotechnical report for the site, whichever is greater.
- Maximum slopes:** must be 3:1 (3H:1V) or flatter (4:1 side slopes are recommended). Slopes exceeding the 3:1 maximum will be required to provide an alternative means to take up vertical grade, such as steps or retaining walls.

SINGLE FAMILY LOT GRADING PLAN REQUIREMENTS:

- SHOW POSITIVE DRAINAGE AWAY FROM ALL STRUCTURES THAT MEETS MINIMUM SLOPE REQUIREMENTS
- SHOW TOP OF FOUNDATION AND/OR FINISHED FLOOR ELEVATION FOR ALL STRUCTURES THAT MEET ELEVATION REQUIREMENTS
- SHOW THAT YOU MEET MAXIMUM AND MINIMUM SLOPE REQUIREMENTS
- 3:1 MAXIMUM SLOPES ALLOWED ON SINGLE FAMILY LOTS ONLY
- SHOW SPOT ELEVATIONS AND 1' INTERVAL PROPOSED CONTOURS
- SHOW THAT BACKYARD SWALES DO NOT DRAIN MORE THAN 3 SEPARATE LOTS

2.0 Site Grading Design

- **Minimum slopes:** one percent (1%) longitudinal grade grass swales may be allowed on single family lots when the swale is draining the runoff from only three (3) adjoining properties. A more typical slope of two percent (2%) is required for swales draining more than three (3) lots.
- **Spot Elevations:** must be included for all locations within the lot that help to illustrate compliance with the drainage and slope requirements stated above. Examples of locations of spot elevations for each different type of lot (type A, B or C) are included in **Figures 2.1-1 through 2.1-3** below.
- **Backyard swales:** The FCU prohibits the use of backyard swales on residential lots where these can be physically avoided. Where these cannot be avoided due to physical or grade constraints, they must be designed in a manner that will minimize the basin area contributing to the backyard swale. As such, backyard swales must not receive runoff from more than three (3) residences. A drainage easement along lot lines will be required in cases where there are three (3) or less residences draining to a common swale. The required minimum width of the easement will be 5 feet (5') on both sides of the lot line, but may be wider as necessary to accommodate the full spread of flow in the easement. In any case where back lot swales are conveying runoff from more than three (3) residential lots, the swale must be placed in a separate legal tract that is owned and maintained by the HOA. In addition, there are fencing restrictions that would prohibit the impedance of drainage flows from one residential lot to an adjacent one. Fencing restrictions must be recorded on the subdivision plat, and the appropriate deed restrictions on that plat must be filed with Larimer County.

Reference: Residential lots are subject to “Individual Lot Certifications”, as discussed in Chapter 3: During & Post-Construction Requirements, of this Manual.

Figure 2.1-1: Type "A" Lot Typical Grading Plan

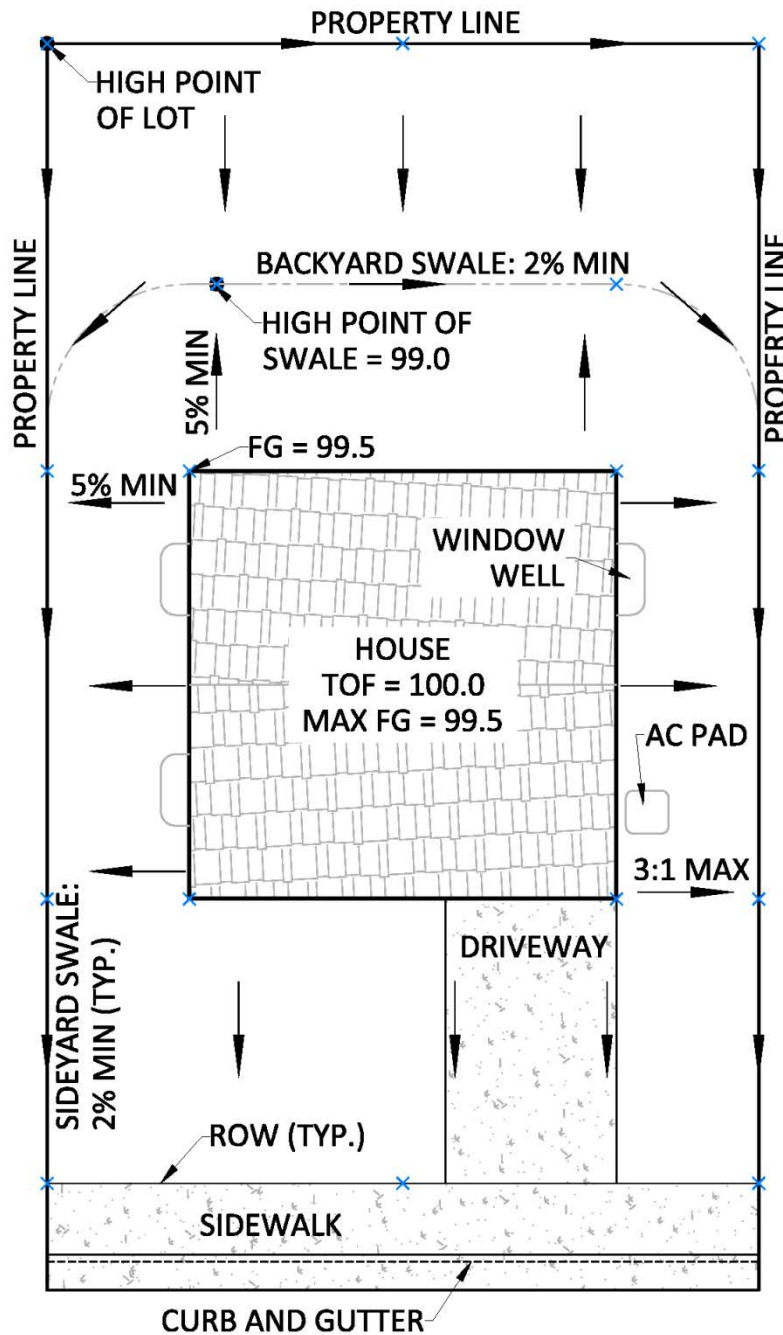

1. SIDEYARD SWALE MINIMUM SLOPE OF 1% ALLOWED FOR 3 OR LESS ADJOINING PROPERTIES
2. HIGH POINT OF BACKYARD SWALE TO BE A MINIMUM OF 12" BELOW THE TOF
3. SPOT ELEVATIONS TO BE PROVIDED ALONG PROPERTY LINES AT 25' INTERVALS AND AT ALL LOCATIONS INDICATED WITH THE SYMBOL x

Figure 2.1-2: Type "B" Lot Typical Grading Plan

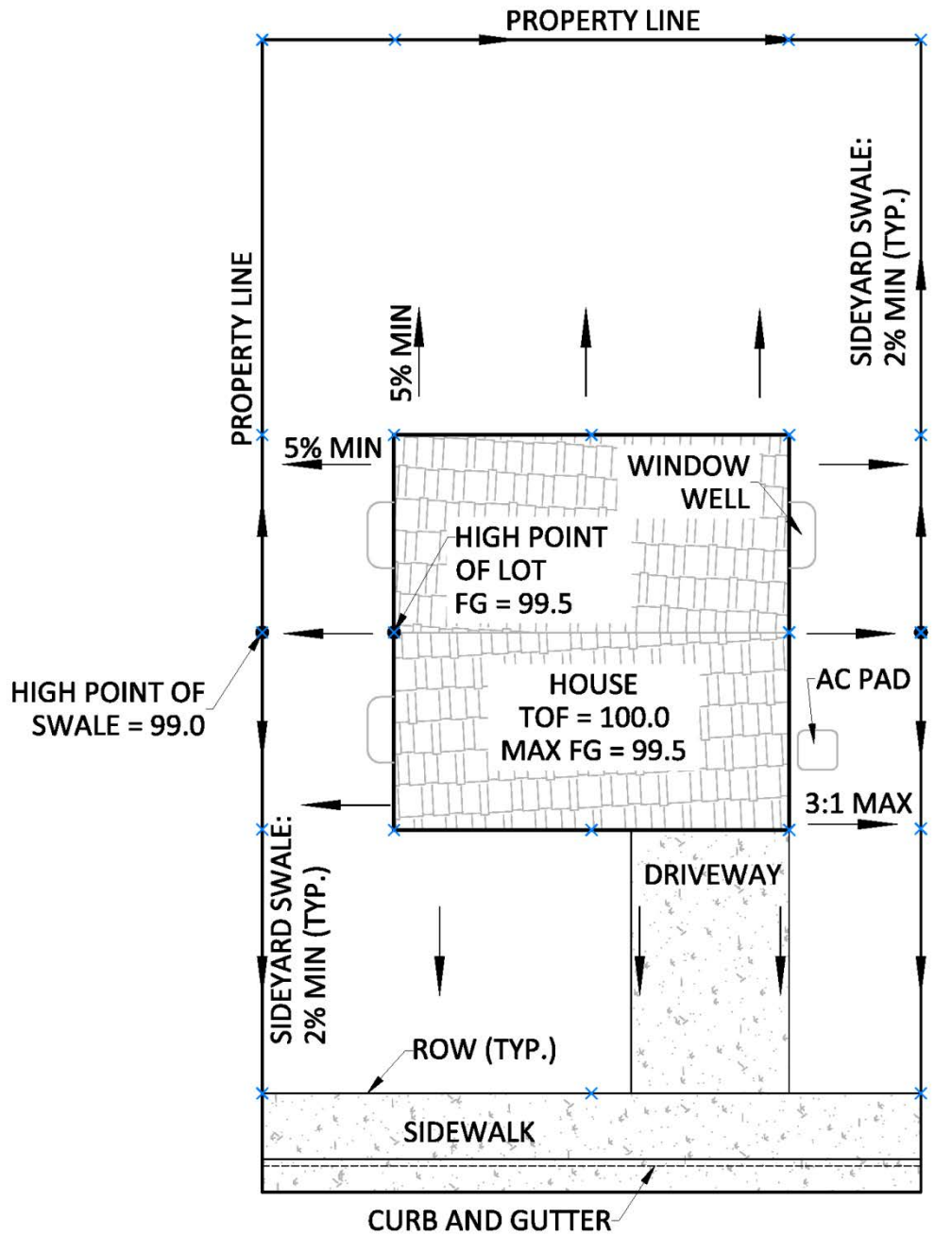

1. SIDEYARD SWALE MINIMUM SLOPE OF 1% ALLOWED FOR 3 OR LESS ADJOINING PROPERTIES
2. HIGH POINT OF SIDEYARD SWALE TO BE A MINIMUM OF 12" BELOW THE TOF
3. SPOT ELEVATIONS TO BE PROVIDED ALONG PROPERTY LINES AT 25' INTERVALS AND AT ALL LOCATIONS INDICATED WITH THE SYMBOL X

Figure 2.1-3: Type "G" and "W" Lot Typical Grading Plan

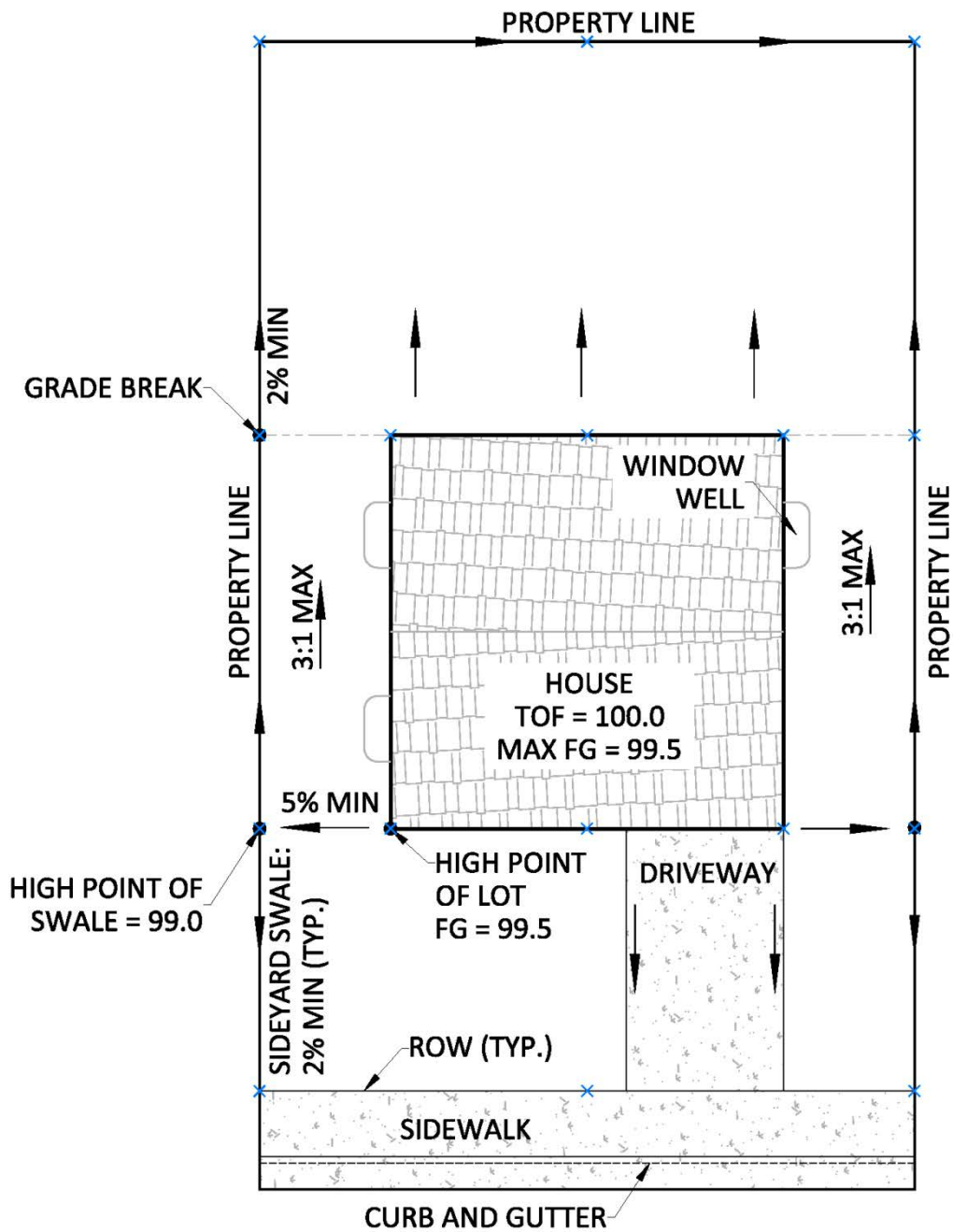

1. SIDEYARD SWALE MINIMUM SLOPE OF 1% ALLOWED FOR 3 OR LESS ADJOINING PROPERTIES
2. HIGH POINT OF SIDEYARD SWALE TO BE A MINIMUM OF 12" BELOW THE TOF
3. 5% MINIMUM SLOPE AWAY FROM STRUCTURE FOR A MINIMUM OF 5'
4. SPOT ELEVATIONS TO BE PROVIDED ALONG PROPERTY LINES AT 25' INTERVALS AND AT ALL LOCATIONS INDICATED WITH THE SYMBOL X

2.2 Surface Grading

Minimum grades required for different types of sheet flow drainage surfaces are as follows:

Table 2.2-1: Minimum Grades for Surfaces

Sheet Flow Minimum Grade Requirements	Surface Treatment
0.50%	Concrete
2.00%	Asphalt
2.00%	Vegetated

- Slopes throughout the site must be no steeper than 4:1 (4H:1V)
- Areas with steep slopes will be required to provide an alternative means to take up vertical grade, such as steps or retaining walls so as to avoid creating slopes steeper than 4:1

2.3 Channel/Swale Grading

As an alternative to storm drains, it is often desirable to create small surface channels or swales to convey runoff from small drainage areas. This section provides guidance for the design of grass and hard surface bottomed swales.

A typical channel/swale cross-section is provided in **Figure 2.3-1** below.

Figure 2.3-1. Typical Channel/Swale Detail

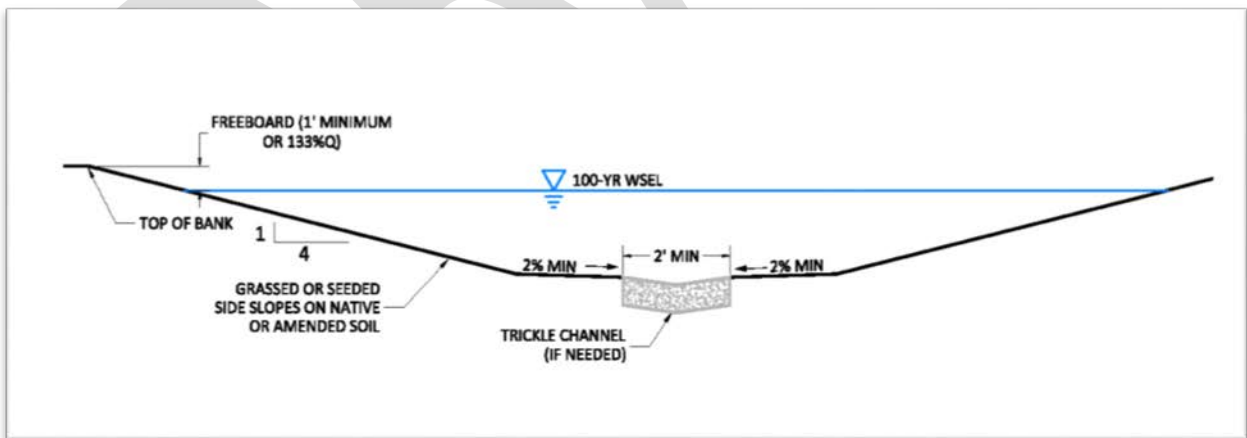

- Side slopes must not exceed 4:1 (4H:1V)
- Channels/swales must be designed with freeboard:

2.0 Site Grading Design

- For channels with > 100 cfs, one foot (1') of freeboard must be provided
- For channels conveying < 100 cfs, the depth of the channel must be able to convey an additional 33% of the 100-year storm flow.
- Maintenance access along the length of the channel must be provided.
- A low-flow or concrete trickle channel is desirable. When concrete trickle channels are utilized for the low flows the following requirements are:
 - Concrete trickle channels must be longitudinally sloped at a minimum of a half percent (0.50%) grade. Slopes toward or perpendicular to the concrete trickle channel must be a minimum of two percent (2%) grade. The use of concrete trickle channels should be avoided in areas with well-draining soils as they reduce infiltration and promote evaporation.
 - Soft pan trickle channels may be utilized when the minimum two percent (2%) grade cannot be achieved; however, the minimum grade allowed for soft pan trickle channels is one percent (1%).
 - Vegetated swales must be graded at a minimum of two percent (2%).

Table 2.3-1. Minimum Grades for Channels/Swales

Channels/Swales Minimum Grade Requirements	Surface Treatment
< 1.00%	Concrete trickle channel required
1.00% - 2.00%	Soft pan trickle channel allowed, concrete not required
>2.00%	Vegetation allowed, concrete not required

Figure 2.3-2. Typical Concrete Trickle Channel Detail

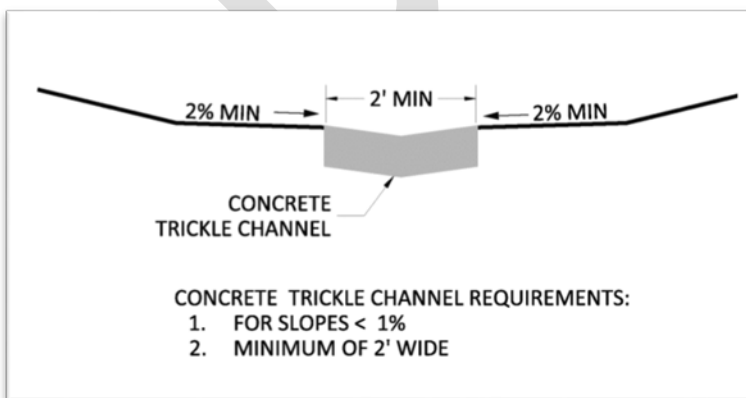

3.0 Detention Basin Grading Design

Figure 2.3-3. Typical Soft Pan Trickle Channel Detail

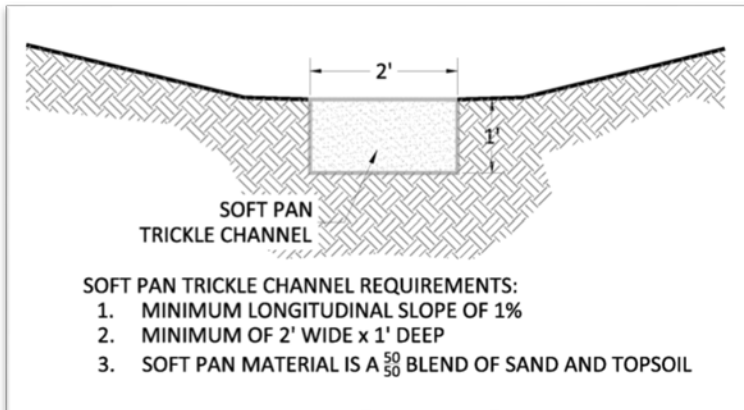

3.0 Detention Basin Grading Design

3.1 Geometry of Stormwater Detention Facilities

Stormwater facilities have a reputation for being functional site features without natural qualities. The basic design parameters for a detention basin design are capacity or volume and rate of discharge. These parameters combined with economic factors typically result in designs that maximize the amount of stormwater detention within the smallest possible area.

These parameters are typically accomplished by the creation of geometric basins with calculated volume and outflow rates, connected to site and local utilities through standard gray concrete structures. The typical detention basin is functional as a facility, yet, provides little or no aesthetic or habitat benefits. In many cases detention basins of this kind detract from the overall project image or appeal and adversely affect surrounding properties.

The geometry of a stormwater detention facility depends on specific site conditions such as adjoining land uses, topography, geology, preserving or creating wildlife habitat, and volume requirements. Several key features must be incorporated in all detention facilities located within Fort Collins:

- Embankments and side slopes are to vary and undulate, with maximum side slopes of four feet horizontal to one foot vertical (4:1) and stabilized. Non-varying slopes and slopes exceeding 4:1 in detention basin areas will not be accepted.

3.0 Detention Basin Grading Design

- Detention basin embankments shall be designed to withstand the 100-year and larger storm. Poorly compacted native soils shall be excavated and replaced. Embankment soils shall be compacted to at least ninety-five percent (95%) maximum density (Modified Proctor) or as specified in the geotechnical report for the site.
- Detention basin bottoms shall have a minimum cross-slope (measured perpendicular to the trickle channel) of two percent (2%) for vegetated surfaces
- Inflow points shall enter the detention basin at or near the toe of the basin to prevent erosion along the basin embankments. If providing an inflow point at the toe of the basin is not feasible, then erosion protection must be provided from the inflow all the way to the toe of the basin.
- Detention basin bottom must be a minimum of twenty four inches (24”) above the groundwater elevation. (Groundwater elevation data must be determined from piezometer data taken during high groundwater months.)
- For safety as well as maintenance considerations, the maximum allowable ponding depth of water in a detention basin during the 100-year storm is ten feet (10’). All detention basins with a water ponding depth of over four feet (4’) must have a water depth gauge. The depth gauge must be referenced to the deepest point in the basin. The numbers on the gauge shall be visible from the detention basin access point or the nearest street.
- Detention basins must be located a minimum of twenty feet (20’) away from an irrigation ditch or other facility, or more if specified by the owner of the irrigation canal and protected from seepage from the irrigation canal.
- An access route into the detention basin must be provided for ingress and egress of maintenance equipment for silt and debris removal as well as repairs. The width, longitudinal slope and surface material of the access route will depend on the type and size of the detention basin but will need to be included in the design and clearly delineated on

DETENTION BASIN LAYOUT REQUIREMENTS:

- MAXIMUM SIDE SLOPES 4:1
- SHOW UNDULATING SIDE SLOPES BETWEEN 10:1 AND 4:1
- MAXIMUM DEPTH OF 10’
- MINIMUM BOTTOM SLOPE OF 2%
- MINIMUM FREEBOARD OF 12” ABOVE 100-YR WSEL
- MAXIMUM SPILL DEPTH OF 6” AT EMERGENCY SPILLWAY
- INFLOW POINTS TO ENTER AT THE TOE OF THE BASIN
- BASIN BOTTOM MUST BE AT LEAST 24” ABOVE GROUNDWATER ELEVATION
- ACCESS ROUTE FOR MAINTENANCE MUST BE PROVIDED

3.0 Detention Basin Grading Design

the plans. (For basins less than one acre-foot in volume, access may be allowed from an adjacent drivable surface that is not within the detention basin area, as long as equipment can safely reach and maintain all of the facilities and appurtenances.)

Figure 3.1-1. Typical Detention Basin

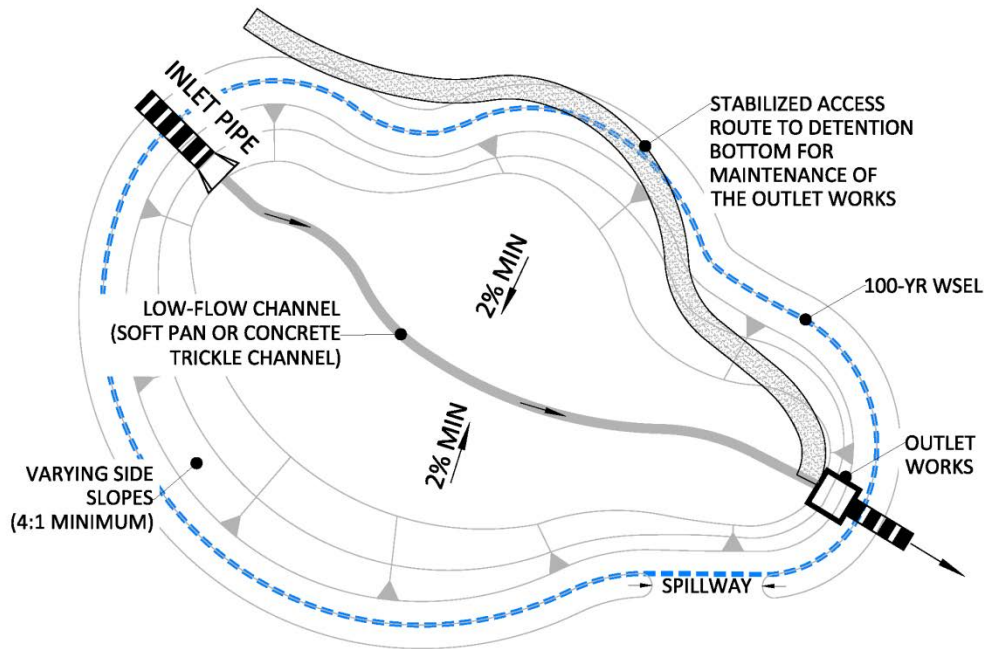

[Reference:](#) For more detailed guidance regarding detention basin aesthetics, refer to the [Landscape Design Standards and Guidelines for Stormwater and Detention Facilities in Appendix B](#).

3.2 Retaining Walls and Safety Railings

The inclusion of retaining walls within detention basins are becoming more commonplace because they add visual character and may aid in providing added volume for small detention areas. However, retaining wall systems can add to maintenance requirements for detention basins as well as cause concerns for safety of maintenance personnel and others that may utilize the area.

The design of any retaining wall system within a detention basin shall be reviewed with FCU early in the design process as the extent and location of retaining walls would need to be reviewed for maintenance, access and safety requirements. For any retaining wall, or multiple walls acting in series, that are

3.0 Detention Basin Grading Design

NOTE ABOUT RETAINING WALLS AND RAILINGS:

RETAINING WALL AND/OR RAILING SYSTEMS WILL NEED TO BE REVIEWED BY FCU IN CONJUNCTION WITH THE BUILDING AND ZONING DEPARTMENTS FOR COMPLIANCE WITH CURRENT BUILDING CODES AND THE LAND USE CODE.

collectively taller than forty eight inches (48") (as measured from the base of the foundation footing to the top of the top wall) will need to be reviewed in conjunction with building code and Land Use Code requirements for height or geometry restrictions.

Use of a safety railing at vertical or steeper than 4:1 structural faces may be required to promote public safety. If the facility is situated at a grade lower than and adjacent to a highway or arterial roadway, installation of a

guardrail will likely be required. Providing features to discourage public access to the inlet and outlet areas of the facility must be considered. Railing requirements will be reviewed on a case-by-case basis and will need to be reviewed in conjunction with the Land Use Code for requirements.

3.3 Trickle Channels

When trickle channels are utilized for the low flows in a detention basin, these are the following requirements:

- Concrete trickle channels must be sloped at a minimum of a half percent (0.50%) grade. Slopes toward or perpendicular to the trickle channel must be a minimum of two percent (2%) grade. Embedded cobbles for a more natural aesthetic are encouraged. (The use of concrete trickle channels should be avoided in areas with well-draining soils as the reduce infiltration and promote evaporation.)
- Soft pan trickle channels may be utilized when the minimum two percent (2%) slope cannot be achieved; however, the minimum slope allowed for soft pan trickle channels is one percent (1%). See **Figure 2.3-3**.
- Vegetated swales must be sloped at a minimum of two percent (2%) to the outlet structure.
- Horizontal alignment shall complement the topographic character of the detention basin and be non-linear.

3.4 Freeboard

Freeboard is the vertical distance above a referenced water surface to a specific elevation associated with constructed infrastructure, typically the lowest elevation of a building site adjacent or nearby. In

3.0 Detention Basin Grading Design

the case of stormwater detention basins, the referenced water surface elevation is the developed condition 100-year water surface elevation. Freeboard requirements are:

- Twelve inches (12") of freeboard is to be provided within the detention basin, measured vertically from the 100-year water surface elevation to the top of the basin, or measured from the emergency spillway elevation (if it is higher than the 100-year water surface elevation) to the top of the basin.
- In all circumstances, twelve inches (12") of freeboard must be provided between the 100-year water surface elevation and the minimum opening elevations of adjacent buildings.

3.5 Spillway

In general, emergency spillways for detention basins are required to include the following parameters:

- The spillway crest must be set at or above the 100-year water surface elevation in the detention basin.
- Emergency overflow depth shall be no more than six inches (6") at the crest during the 100-year storm.
- The detention basin top of embankment shall be a minimum of twelve inches (12") above the spillway crest elevation.
- Erosion protection including the use of buried riprap or other permanent erosion control protection devices required on the downstream side of the embankment from the crest of the spillway to the toe of slope.
- Concrete overflow wall may be required along the length of the spillway at the discretion of FCU. Specific design requirements that may include footing design, reinforcement and concrete mix requirements are to be provided in a construction detail by the Design Engineer. The general design parameters are shown in **Figure 3.5-1** below.
- Provide overflow routing to adequate conveyance system.

In cases where a detention basin is situated adjacent to a roadway, the roadway itself may be considered a stabilized embankment.

3.0 Detention Basin Grading Design

Figure 3.5-1. Spillway Detail and Rock Sizing Chart

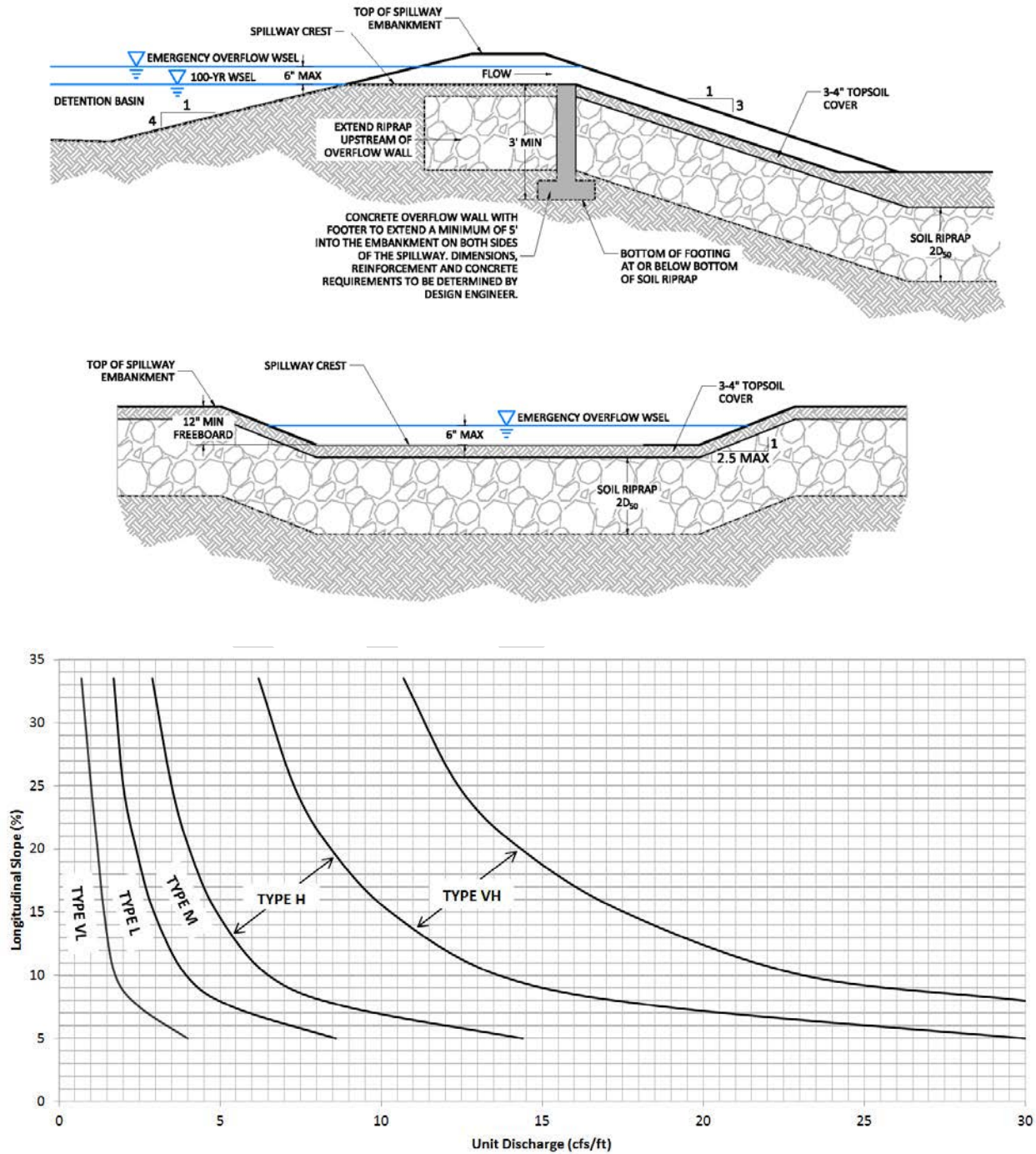

4.0 Landscaping

Excerpts from the “City of Fort Collins Landscape Design Standards and Guidelines for Stormwater and Detention Facilities”, dated November 2009, found in Appendix B of this Manual should be referenced for planting design and techniques, irrigation, habitat value and maintenance standards for integration into the overall site and stormwater design. Landscape designs must meet Land Use Code requirements but must also incorporate the principles discussed in the landscape standards for detention facilities document as well as include proper seed mixes for erosion control and vegetation establishment, as provided in Chapter 4: Construction Control Measures.

[Reference](#): Designers are encouraged to review the [Nature in the City Design Strategic Plan](#) as well as the [Landscape Design Standards and Guidelines for Stormwater and Detention Facilities](#) found in Appendix B.

5.0 Drainage Easements

Drainage easements dedicated to the City are required for certain stormwater facilities for the purposes of allowing access to the facilities by the owner, maintenance agency and for City inspection and other purposes.

Drainage easements are required to be provided for:

- **Open channels or swales** on private property that convey offsite runoff or a combination of offsite runoff and runoff generated onsite. The offsite runoff does not have to be from a public right-of-way. The easement shall include the entire width of the channel from top of bank to top of bank and including area adjacent to one or both of top of banks to allow for a ten foot (10') wide maintenance vehicle access, or a minimum of 20' total width, whichever is greater. The easement shall be along the entire length of the channel.
- **Detention basins**, public or privately owned and maintained. The easement shall include the entire area encompassing the basin itself, side slopes into the basin, the entirety of the 100-year water surface elevation and freeboard, all appurtenances necessary for the outfall, operation and maintenance of the facility which may also include additional width beyond the top of bank of the basin to allow for maintenance vehicle access.
- Volume-based **water quality basins**, including volume-based **LID systems**, including any outfall facilities.

Drainage easements do **not** need to be provided for:

- Open channels or swales that are on private property that only convey runoff that is generated on that property

- Non-volume-based water quality basins, including LID systems that are not designed for a specific volume (i.e. permeable pavers without detention, linear bioretention)

DRAFT

Chapter 9: Streets, Inlets & Conveyance

Contents

- 1.0 Overview 1
 - 1.1 Purpose and Background 1
 - 1.2 Urban Stormwater Collection and Conveyance Systems..... 2
 - 1.3 System Components 2
 - 1.4 Minor and Major Storms..... 2
- 2.0 Street Drainage 3
 - 2.1 Encroachment Standards..... 3
 - 2.2 Hydraulic Evaluation 5
 - 2.2.1 Curb and Gutter 5
 - 2.2.2 Swale Capacity 9
- 3.0 Inlets..... 10
 - 3.1 Inlet Function and Selection 10
 - 3.2 Design Considerations..... 10
 - 3.3 Inlets on a Continuous Grade 12
 - 3.3.1 Grate Inlets on a Continuous Grade 12
 - 3.3.2 Curb-Opening Inlets on a Continuous Grade 12
 - 3.3.3 Combination Inlets on a Continuous Grade..... 13
 - 3.3.4 Inlet Location and Spacing on Continuous Grades 13
 - 3.4 Inlets in a Sump..... 14
 - 3.4.1 Grate Inlets in a Sump (UDFCD-CSU Model)..... 14
 - 3.4.2 Curb-Opening Inlets in a Sump (UDFCD-CSU Model) 15
 - 3.4.3 Other Inlets in a Sump (Not Modeled in the UDFCD-CSU Study) 17
 - 3.4.4 Inlet Clogging..... 19
 - 3.5 UD-Inlet Design Workbook 19
 - 3.6 Nuisance Flows..... 20
- 4.0 Storm Drain Systems..... 24
 - 4.1 Introduction 24
 - 4.2 Easements for Storm Pipes 25
 - 4.3 Design Process, Considerations and Constraints..... 25

Chapter 9: Streets, Inlets & Conveyance

- 4.4 Storm Drain Hydrology and Hydraulics..... 27
- 5.0 Swales 28
 - 5.1 Design Criteria for Swales 29
 - 5.1.1 Stability Charts 30
 - 5.2 Grass Swales..... 30
 - 5.2.1 Soil and Vegetation Properties 30
 - 5.2.2 Construction..... 31
- 6.0 Use of Irrigation Ditches 36
- 7.0 Energy Dissipation and Erosion Protection..... 37
 - 7.1 Use of Riprap Policy 38
 - 7.2 Riprap Apron 39
 - 7.2.1 Multiple Conduit Installations..... 40
 - 7.3 Rock Sizing for Riprap Apron..... 43

1.0 Overview

The vast majority of this Chapter is taken directly from the Streets, Inlets and Storm Drains Chapter in the 2016 UDFCD Manual. There are segments of that chapter of the UDFCD Manual that show the derivation of calculating complex street capacities, capture efficiencies of inlets, the hydraulics of piping networks as well as several example calculations that have not been included here. The Design Engineer should reference the UDFCD Manual or other appropriate reference material for thorough discussion and understanding of these items.

1.1 Purpose and Background

The purpose of this Chapter is to provide design guidance for stormwater collection and conveyance utilizing streets, inlets, storm drains and other conveyances. Procedures and equations for the hydraulic design of street drainage, locating inlets and determining capture capacity, and sizing storm drains are not presented here but can be referenced in the UDFCD Manual.

The design procedures presented in this Chapter are based upon fundamental hydrologic and hydraulic design concepts. It is assumed that the reader has an understanding of basic hydrology and hydraulics. A working knowledge of the Rational Method (discussed in Chapter 5: Hydrology Standards Chapter) and open channel hydraulics (discussed in the UDFCD Manual) is particularly helpful. The design equations provided are well accepted and widely used. They are presented without derivations or detailed explanation but are properly referenced if the reader wishes to study their background.

Inlet capacity has been studied in great depth at the UDFCD. Determining inlet capacity and further refinement of the methodologies through multi-jurisdictional partnerships led by UDFCD, where hundreds of physical model tests of inlets commonly used in Colorado were performed at the Colorado State University (CSU) Hydraulics Laboratory. The physical model study is further detailed in technical papers available at www.udfcd.org.

UDFCD Reference: UDFCD has developed an inlet design tool, UD-Inlet, which incorporates the findings of the physical model. UD-Inlet is commonly used and an acceptable software tool for use in determining street capacity and sizing inlets for systems in Fort Collins. The UD-Inlet spreadsheet is available at www.udfcd.org/software

Other design tools may also be available and utilized with prior approval from FCU.

1.2 Urban Stormwater Collection and Conveyance Systems

Proper and functional urban stormwater collection and conveyance systems:

- Promote safe passage of vehicular traffic during minor storm events
- Maintain public safety and manage flooding during major storm events
- Minimize capital and maintenance costs of the system

Urban stormwater collection and conveyance systems are critical components of the urban infrastructure. Proper design is essential to minimize flood damage and limit disruptions. The primary function of the system is to collect excess stormwater in street gutters, convey it through storm drains and along the street right-of-way, and discharge it into a detention basin, water quality best management practices (BMP), or nearest receiving water body (FHWA 2009).

1.3 System Components

Urban stormwater collection and conveyance systems are comprised of three primary components:

- 1) Street gutters and roadside swales
- 2) Storm drain inlets
- 3) Storm drains (with appurtenances like manholes, junctions, etc.)

Street gutters and roadside swales collect runoff from the street (and adjacent areas) and convey the runoff to a storm drain inlet while maintaining the street's level of service.

Inlets collect stormwater from streets and other land surfaces, transition the flow into storm drains, and provide maintenance access to the storm drain system. Storm drains convey stormwater in excess of street or swale capacity along the right-of-way and discharge into a stormwater management facility or directly into a receiving water body. All of these components must be designed properly to achieve the objectives of the stormwater collection and conveyance system.

1.4 Minor and Major Storms

Rainfall events vary greatly in magnitude and frequency of occurrence. Major storms produce large flow rates but rarely occur. Minor storms produce smaller flow rates but occur more frequently. For economic reasons, stormwater collection and conveyance systems are not normally designed to pass the peak discharge during major storm events without some street flooding.

Stormwater collection and conveyance systems are designed to pass the peak discharge of the minor storm event (and smaller events) with minimal disruption to street traffic. To accomplish this, the spread

2.0 Street Drainage

and depth of water on the street is limited to a maximum mandated value during the minor storm event. Inlets must be strategically placed to pick up excess gutter or swale flow once the limiting allowable spread or depth of water is reached. The inlets collect and convey stormwater into storm drains, which are typically sized to pass the peak flow rate (minus the allowable street flow rate) from the minor storm without any surcharge. In Fort Collins, the magnitude of the minor storm event is defined as the 2-year storm.

In Fort Collins, the return period for the major storm event is defined as the 100-year storm. During this event, runoff exceeds the minor storm allowable spread and depth in the street and capacity of storm drains. Street flooding may occur and traffic may be disrupted as the street functions as an open channel. The Design Engineer must evaluate and design for the major event with regard to maintaining public safety and minimizing flood damages.

2.0 Street Drainage

Although streets play an important role in stormwater collection and conveyance, the primary function of a street or roadway is to provide for the safe passage of vehicular traffic at a specified level of service. If stormwater systems are not designed properly, this primary function will be impaired. Proper street drainage is essential to:

- Maintain the street's level of service
- Minimize danger and inconvenience to pedestrians during storm events (FHWA 1984)
- Reduce potential for vehicular skidding and hydroplaning
- Maintain good visibility for drivers (by reducing splash and spray)
- Maintain access for emergency vehicles

Reference: The [Larimer County Urban Area Street Standards \(LCUASS\)](#) shall be referenced for all street classification and design requirements for each project.

2.1 Encroachment Standards

The encroachment criteria provided in the tables below applies to public streets. Where there is a floodplain designation, Chapter 10 of the City code shall also apply. Encroachment in this context is defined as the extent of which stormwater is allowed to extend into the public roadway in terms of width and depth.

Table 2.1-1: Street Encroachment Standards for the Minor (2-Year) Storm

Street Classification	Maximum Encroachment
Local, Alley	<ul style="list-style-type: none"> No curb-overtopping. Flow may spread to crown of street.
Collector, Arterial (without median)	<ul style="list-style-type: none"> No curb-overtopping. Maximum allowable depth at gutter is 6 inches (6"). Flow spread must leave a minimum of 6 feet (6') wide clear travel lane on each side of the centerline.
Arterial (with median)	<ul style="list-style-type: none"> No curb-overtopping. Maximum allowable depth at gutter is 6 inches (6"). Flow spread must leave a minimum of 12 feet (12') wide travel lane in both directions of travel.

Note: Encroachment may not extend past the public right-of-way or into private property.

Table 2.1-2: Street Encroachment Standards for the Major (100-Year) Storm

Street Classification	Maximum Encroachment
Local, Alley, Collector, Arterial (without median)	<ul style="list-style-type: none"> Maximum allowable depth at crown is 6 inches (6") and must allow for the operation of emergency vehicles. Maximum allowable depth at gutter is 12 inches (12"). The most restrictive of these criteria will apply.
Arterial (with median)	<ul style="list-style-type: none"> Maximum allowable depth must not exceed bottom of gutter at the median and must allow for the operation of emergency vehicles. Maximum allowable depth at gutter is 12 inches (12"). The most restrictive of these criteria will apply.

Note: Encroachment may not extend past utility easements that parallel the public right-of-way.

Table 2.1-3: Allowable Cross-Street Flow

Street Classification	Minor (2-Year) Storm	Major (100-Year) Storm
Local	Maximum allowable depth in crossspan is 6 inches	Maximum allowable depth at flowline is 18 inches (18")
Collector	Maximum allowable depth in crossspan is 6 inches (only where crossspans are allowed)	Maximum allowable depth at flowline is 12 inches (12")
Arterial	No cross-flow allowed	No cross-flow allowed. Maximum depth at arterial/local intersections shall not exceed arterial depth maximums (i.e. 12 inches (12"))

Note: Encroachment may not extend past utility easements that parallel the public right-of-way.

Once the allowable street encroachment has been established for the minor storm, the placement of inlets can be determined. The inlets will remove some or all of the excess stormwater and thus reduce the spread. It should be noted that proper drainage design utilizes the full allowable capacity of the street gutter in order to limit the cost of inlets and storm sewers.

At street sump locations, proper inlet sizing and design will be required to ensure that the 100-year flows can be carried to the storm pipes or an overflow channel to an acceptable outfall while the maximum water surface depth criteria are not surpassed. Inlet design is discussed in the next section of this Chapter.

A drainage easement for drainage overflow drainage must be granted to the City for access and maintenance if the stormwater flows are not contained within the public right-of-way.

Two additional design considerations are gutter geometry and street slope. Most urban streets incorporate curb and gutter sections. Various types exist, including spill shapes, catch shapes, curb heads and mountable curbs. The shape is chosen for function, cost or aesthetic reasons and does not dramatically affect the hydraulic capacity. Swales are used along some semi-urban streets and roadside ditches are common along rural streets. Cross-sectional geometry, longitudinal slopes and swale/ditch roughness values are important in determining hydraulic capacity and are covered in the next section.

2.2 Hydraulic Evaluation

Hydraulic computations are performed to determine the capacity of roadside swales and street gutters and the encroachment of stormwater onto the street. The design discharge is based on the peak flow rate and usually is determined using the Rational Method. Although gutter and street flows are unsteady and non-uniform, steady, uniform flow is assumed for the short time period of peak flow conditions.

2.2.1 Curb and Gutter

Both the longitudinal and cross (transverse) slope of a street are important in calculating hydraulic capacity. The capacity of the street increases as the longitudinal slope increases. Public safety considerations limit the maximum allowable flow capacity of the gutter on steep slopes. The cross-slope represents the slope from the street crown to the interface with the lip of the gutter, measured perpendicular to the direction of travel. Use of standard curb and gutter sections typically produces a

STREET HYDRAULIC CAPACITY:

REFERS TO THE CAPACITY FROM THE FACE OF THE CURB TO THE CROWN (FOR THE MINOR EVENT.) TYPICALLY, THE HYDRAULIC COMPUTATIONS NECESSARY TO DETERMINE STREET CAPACITY AND REQUIRED INLET LOCATIONS ARE PERFORMED INDEPENDENTLY FOR EACH SIDE OF THE STREET. ADDITIONALLY, FLOW AND STREET GEOMETRY MAY DIFFER FROM ONE SIDE OF THE STREET TO THE OTHER.

composite section with milder cross-slopes for drive lanes and steeper cross-slopes within the gutter width for increased flow capacity.

Reference: [LCUASS](#) criteria will stipulate minimum and maximum allowable longitudinal and cross-slopes allowed for new and reconstructed roadways.

Capacity When Gutter Cross-Slope Equals Street Cross-Slope (Not Typical)

Streets with uniform cross-slopes like that shown in **Figure 2.2.1-1** are sometimes found in older urban areas. Since gutter flow is assumed to be uniform for design purposes, a modified Manning's equation is appropriate to use in this instance.

Figure 2.2.1-1. Gutter Section with Uniform Cross-Slope

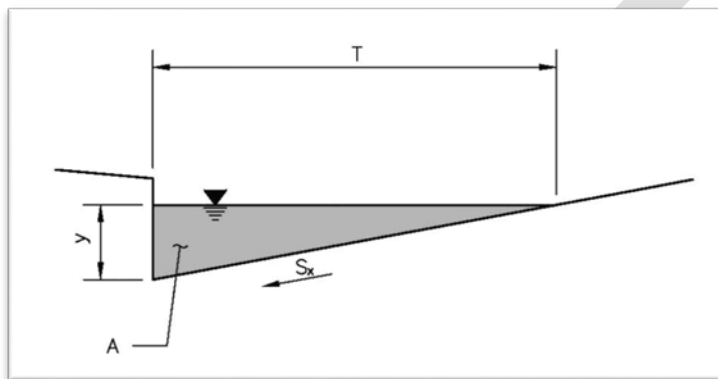

For the triangular cross-section shown in the Figure above, flow rate in the gutter can be found using the Manning's equation, written as:

$$Q = \frac{0.56}{n} S_x^{5/3} S_o^{1/2} T^{8/3} \quad \text{Equation 9-1}$$

Where:

- Q = calculated flow rate for the half-street, cfs
- n = Manning's roughness coefficient, dimensionless
- S_x = street cross-slope, ft/ft
- S_o = street longitudinal slope, ft/ft
- T = top width of flow spread, ft

The flow depth can be found using:

$$y = TS_x \quad \text{Equation 9-2}$$

Where:

- y = flow depth at the gutter flowline, ft

Note that the flow depth shall not exceed the curb height during the minor storm based on the criteria in **Table 2.1-1**.

Reference: The description and derivation of the Manning's equation modification can be found in the Streets, Inlets & Storm Drains Chapter of the UDFCD Manual.

Capacity When Gutter Cross-Slope is Not Equal to Street Cross-Slope (Typical)

Streets with composite cross-slopes like that shown in **Figure 2.2.1-2** are often used to increase the gutter capacity and keep nuisance flows out of the travel lanes.

Figure 2.2.1-2. Typical Gutter Section with Composite Cross-Slope

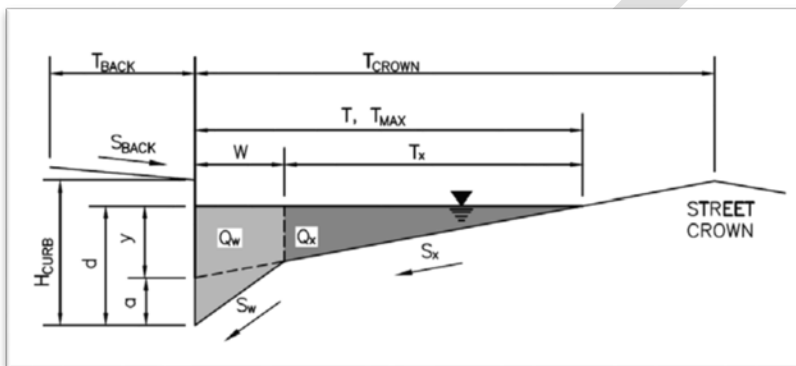

Determining the flow rate for composite street sections involves first determining the flow in the street (not the gutter) then determining the ratio of gutter flow to total flow, then computing the theoretical flow rate for the composite cross-section. Due to the complexity of this calculation procedure, it is recommended that the Design Engineer review the information presented in the UDFCD Manual for more thorough understanding. The UD-Inlet design workbook is an allowable design tool that incorporates these calculations into it.

Reference: The fundamentals of determining street capacities are further explored and presented in the other reference manuals including the UDFCD Manual.

Allowable Capacity

Stormwater flows along streets exert momentum forces on cars, pavement and pedestrians. To limit the hazardous nature of large street flows, it is necessary to set limits on flow velocities and depths. As a result, the allowable half-street hydraulic capacity is determined as the lesser of:

$$Q_A = Q_T$$

Equation 9-3

Or

$$Q_A = RQ_d$$

Equation 9-4

Where:

- Q_A = allowable street hydraulic capacity, cfs
- Q_T = street hydraulic capacity where flow spread equals allowable spread, cfs
- R = reduction factor (allowable street and gutter flow for safety), dimensionless
- Q_d = street hydraulic capacity where flow depth equals allowable depth, cfs

There are two sets of safety reduction factors developed for the UDFCD region (Guo 2000b) and included in the design standards of this Manual. One is for the minor event and the other is for the major event. **Figure 2.2.1-3** shows that the safety reduction factor does not apply unless the street longitudinal slope is more than 1.5% for the major event and 2% for the minor event. The safety reduction factor, representing the fraction of calculated gutter flow at maximum depth that is used for the allowable design flow, decreases as longitudinal slope increases.

It is important that street drainage design includes the allowable street hydraulic capacity using reduction factors. Where the accumulated stormwater amount on the street approaches the allowable capacity, a street inlet should be installed.

Figure 2.2.1-3. Reduction factor for gutter flow (Guo 2000b)

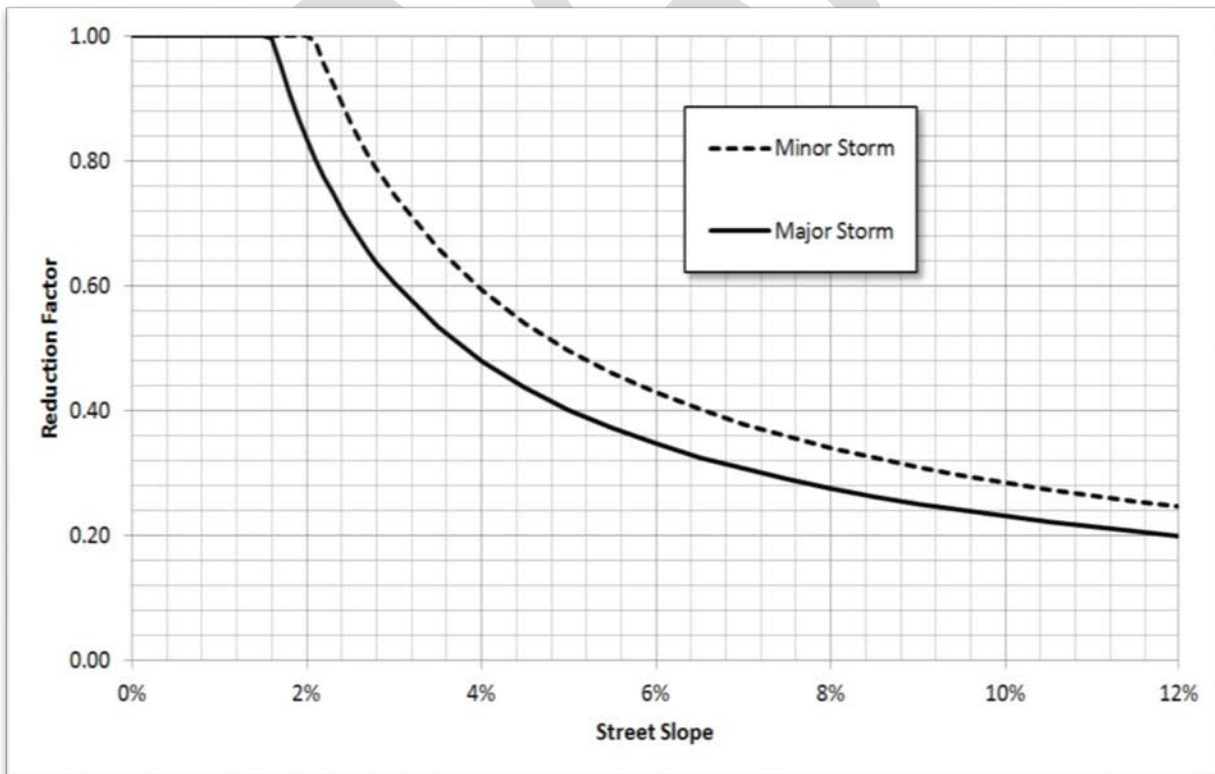

2.2.2 Swale Capacity

Where curb and gutter are not used to contain flow, swales are frequently used to convey runoff and disconnect impervious areas. It is very important that swale depths and side slopes be shallow for safety and maintenance reasons. Street side drainage swales are not the same as roadside ditches. Street side drainage swales provide mild slopes and are frequently designed to provide water quality enhancement. For purposes of disconnecting impervious area and reducing the overall volume of runoff, swales should be considered as collectors of initial runoff for transport to other larger means of conveyance. To be effective, they need to be limited to a stable velocity, depth and cross-slope geometries.

Equation 9-5 can be used to calculate the flow rate in a V-section swale (using the appropriate roughness value for the swale surface) with an adjusted cross-slope found using:

$$S_x = \frac{S_{x1}S_{x2}}{S_{x1}+S_{x2}}$$

Equation 9-5

Where:

S_x = adjusted side slope, ft/ft

S_{x1} = right side slope, ft/ft

S_{x2} = left side slope, ft/ft

Figure 2.2.2-1 shows the geometric variables.

Figure 2.2.2-1. Typical V-Shaped Swale Section

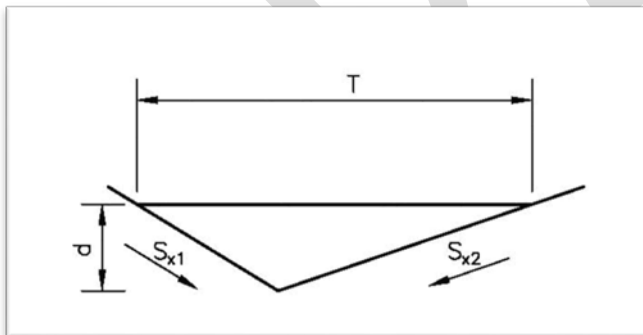

Note that the slope of a roadside ditch or swale can be different than the adjacent street. The hydraulic characteristics of the swale can therefore change from one location to another and should be analyzed where appropriate.

VELOCITY x DEPTH:

FOR SAFETY REASONS, PAVED SWALES (E.G. SWALES WITH CONCRETE TRICKLE CHANNELS) SHOULD BE DESIGNED SUCH THAT THE PRODUCT OF VELOCITY AND DEPTH IS NO MORE THAN SIX (6) FOR THE MINOR STORM AND EIGHT (8) FOR THE MAJOR STORM.

3.0 Inlets

3.1 Inlet Function and Selection

Inlets collect excess stormwater from the street, transition the flow into storm drains and can provide maintenance access to the storm drain system. There are three major types of inlets: grate, curb opening and combination. **Table 3.1-1** provides considerations in proper selection.

Table 3.1-1. Inlet Selection Considerations

Inlet Type	Applicable Setting	Advantages	Disadvantages
Grate	Sumps and continuous grades (should be made bicycle safe)	Perform well over wide range of grades	Can become clogged. Can lose some capacity with increasing grade
Curb-Opening	Sumps and continuous grades (but not steep grades)	Do not clog easily, bicycle safe	Lose capacity with increasing grade
Combination	Sumps and continuous grades (should be made bicycle safe)	Intercept flow over wide section	Susceptible to clogging

3.2 Design Considerations

Frequently, roadway geometry dictates the location of inlets. Inlets are placed at low points (sumps), median breaks and at intersections. Additional inlets should be placed where the design peak flow on the street half is approaching the allowable capacity of the street half. Allowable street capacity will be exceeded and storm drains will be underutilized when inlets are not located properly or not designed for adequate capacity. (Akan and Houghtalen, 2002)

Inlets placed on continuous grades are generally designed to intercept only a portion of the gutter flow during the minor storm (i.e. some flow bypasses to downgradient inlets).

The effectiveness of the inlet is expressed as efficiency defined as:

$$E = Q_i / Q \tag{Equation 9-6}$$

Where:

- E = inlet efficiency (fraction of gutter flow captured by the inlet)
- Q_i = intercepted flow rate, cfs
- Q = total half-street flow rate, cfs

Bypass (or carryover) flow is not intercepted by the inlet. By definition,

$$Q_b = Q - Q_i \quad \text{Equation 9-7}$$

Where:

Q_b = bypass (or carryover) flow rate, cfs

The ability of an inlet to intercept flow (i.e. hydraulic capacity) on a continuous grade increases to a degree with increasing gutter flow, but the capture efficiency decreases. In general, the inlet capacity depends on:

- The inlet type and geometry (length, width, curb opening, etc.)
- The flowrate
- The longitudinal slope
- The cross (transverse) slope

The capacity of an inlet varies with the type of inlet. For grate inlets, the capacity is largely dependent on the amount of water flowing over the grate, the grate configuration and spacing. For curb-opening inlets, the capacity is largely dependent on the length of the opening, street and gutter cross-slope and the flow depth at the curb. Local gutter depression at the curb opening will increase capacity. FCU requires that all curb-opening throats must be installed with the bottom of the opening at least two inches (2") below the flowline elevation. The minimum transition length allowed is five feet (5').

Combination inlets on a continuous grade (i.e. not a sump condition) intercept up to 18% more than grate inlets alone and are much less likely to clog completely (CSU 2009).

TYPE R INLET RESTRICTIONS:

- THROAT OPENINGS SHALL BE AT LEAST 2" BELOW FLOWLINE ELEVATION
- FOR PUBLIC SAFETY CONCERNS, THROAT OPENINGS MUST NOT EXCEED 6".
- MINIMUM TRANSITION LENGTH FROM FLOWLINE TO THROAT IS 5'
- TYPE R INLETS ARE DISCOURAGED FROM BEING PLACED ON LOCAL STREETS OR RESIDENTIAL AREAS UNLESS THERE ARE PHYSICAL CONSTRAINTS THAT WOULD EXCLUDE THE USE OF COMBO INLETS.

Inlets in sumps operate as weirs at shallow ponding and as orifices as depth increases. A transition region exists between weir flow and orifice flow, much like a culvert. Grate inlets and slotted inlets have

a higher tendency to clog with debris than do curb opening inlets, so calculations should take that into account.

Reference: The methodology for determining the hydraulic capacity of the various inlet types is documented in the UDFCD Manual. Refer to that manual for in-depth hydraulic design information for inlets.

Photograph 3.2-1. These street inlets are the most commonly used in Fort Collins. Their performance was tested for both on-grade conditions and in sump conditions in a 1/3 scale physical model at CSU.



(a) CDOT Type 13 grated inlet in combination configuration



(b) CDOT Type R curb opening inlet

3.3 Inlets on a Continuous Grade

3.3.1 Grate Inlets on a Continuous Grade

The capture efficiency of a grate inlet on a continuous grade is highly dependent on the width of the grate and, to a lesser degree, the length. In general, most of the flow within the width of the grate will be intercepted and most of the flow outside of the width of the grate (i.e. in the street) will not. The velocity of gutter flow also affects capture efficiency. If the gutter velocity is low and the spread of water does not exceed the grate width, all of the flow will be captured by the grate inlet. However, this is not normally the case, even during the minor storm. The spread of water often exceeds the grate width and the flow velocity can be high. Thus, some of the flow within the width of the grate may splash over the grate, and unless the inlet is very long, very little of the flow outside the grate width is captured.

3.3.2 Curb-Opening Inlets on a Continuous Grade

The capture efficiency of a curb-opening inlet is dependent on the length of the opening, the depth of flow at the gutter flow line, street cross-slope and the longitudinal gutter slope. If the curb opening is

long, the flow rate is low and the longitudinal gutter slope is small, all of the flow will be captured by the inlet. It is generally uneconomical to install a curb-opening long enough to capture all of the flow during the minor storm. Thus, some water gets by the inlet, and the inlet efficiency needs to be determined.

3.3.3 Combination Inlets on a Continuous Grade

Combination inlets take advantage of the debris removal capabilities of a curb-opening inlet and the capture efficiency of a grate inlet. Combination inlets on a continuous grade (i.e. not in a sump location) intercept 18% more than grate inlets alone and are much less likely to clog completely (CSU 2009). A special case combination where the curb opening extends upstream of the grated section is called a sweeper inlet. The inlet capacity is enhanced by the additional upstream curb-opening length and debris is intercepted there before it can clog the grate. The construction of sweeper inlets is more complicated and costly, however, and they are not commonly seen in Fort Collins. To calculate interception efficiency for a sweeper inlet, the upstream curb-opening efficiency is calculated first and then the interception efficiency for combination section based on the remaining street flow is added to it. To analyze this within UD-Inlet, select *user-defined combination*, select a grate type, and check the *sweeper configuration* box.

3.3.4 Inlet Location and Spacing on Continuous Grades

Although one should always perform interception capacity computations on stormwater inlets, the ultimate location (or positioning) of those inlets is rarely a function of interception alone. Often, inlets are required in certain locations based upon street design considerations and topography (low points). One notable exception is the location and spacing of inlets on continuous grades. On a long continuous grade, stormwater flow increases as it moves down the gutter and picks up more drainage area. As the flow increases, so does the spread (encroachment) and depth (inundation). Since the spread and depth are not allowed to exceed the specified maximum (see **Tables 2.1-1** and **2.1-2**), inlets must be strategically placed to remove some of the stormwater from the street. Locating these inlets requires design computations by the Design Engineer.

Proper design of stormwater collection and conveyance systems makes optimum use of the conveyance capabilities of street gutters, such that an inlet is not needed until the spread (encroachment) and depth (inundation) reach allowable limits during the design (minor) storm. To place an inlet prior to that point on the street is not economically efficient. To place an inlet after that point would violate the encroachment and inundation standards. Therefore, the primary design objective is to position inlets along a continuous grade at the locations where the allowable spread and/or depth is about to be exceeded for the design storm. The ultimate goal is to always place an inlet just upstream of the point where the allowable spread and/or criteria would otherwise be exceeded.

Once the first inlet location is identified along a continuous grade, an inlet type and size can be specified. The first inlet's hydraulic capacity is then assessed. Generally, it is uneconomical to size an inlet (on continuous grades) large enough to capture all of the gutter flow. Instead, some carryover flow is expected. This practice reduces the amount of new flow that can be picked up at the next inlet. However, each inlet should be positioned at the location where the spread or depth of flow is about to

reach its allowable limit. For placement of inlets on a continuous grade, the Design Engineer should not only analyze length of the grate opening to capture a required amount of flow (which may result in a very long inlet bank), but also analyze the placement of dispersed inlets along the continuous grade to capture the required amount of flow. As discussed further in Section 3.4.2, weir performance decay can also play a part in reducing the effectiveness of long inlet banks.

The gutter discharge for inlets (other than the most upstream inlet), consists of the carryover (bypassed) flow from the upstream inlet plus the stormwater runoff generated from the intervening local drainage area. The carryover flow from the upstream inlet is added to the peak flow rate obtained from the Rational Method for the intervening local drainage area. The resulting peak flow is conservatively approximate since the carryover flow peak and local runoff peak do not necessarily coincide.

[Reference:](#) UD-Inlet design workbook is available for download from the UDFCD website and is a widely used design tool accepted by FCU. The examples provided at the end of the Street, Inlets & Storm Drains Chapter in the UDFCD Manual for inlet calculations show how to calculate the capture efficiency and the overall flow capture for inlets.

3.4 Inlets in a Sump

3.4.1 Grate Inlets in a Sump (UDFCD-CSU Model)

All of the stormwater draining to a sump inlet must pass through an inlet grate or curb-opening to enter the storm drain. This means that clogging due to debris can result not only in underutilized pipe conveyance, but also ponding of water on the surface. Surface ponding can be a nuisance or hazard. Therefore, the capacity of inlets in sumps must account for this clogging potential. Grated inlets alone are not allowed on roadways for this reason. Curb-opening and combination (including sweeper) inlets are more appropriate. In all sump inlet locations, consider the risk and required maintenance associated with a full clogged condition and design the system accordingly.

Photograph 3.3.4-1. Inlets that are located in street vertical sag curves (sumps) are highly efficient.



Photograph 3.3.4-1 shows a curb-opening inlet in a sump condition. At this location, if the inlet clogs, standing water will be limited to the elevation at the back of the walk.

Flow through a grated sump inlet varies with respect to depth and continuously changes from weir flow (at shallow depths) to mixed flow (at intermediate depths), and also orifice

flow (at greater depths). For commonly used grated street inlets in the UDFCD region, a UDFCD-CSU physical model study was conducted to more accurately measure the interception capacity of grated inlets.

Reference: The UDFCD-CSU physical model study is discussed in the Streets, Inlets & Storm Drains chapter of the UDFCD Manual.

3.4.2 Curb-Opening Inlets in a Sump (UDFCD-CSU Model)

Like a grate inlet, a curb-opening inlet operates under weir, orifice, or mixed flow. From the UDFCD-CSU physical model study, the HEC-22 procedure was found to overestimate the capacity of the CDOT Type R and other similar curb-opening inlets for the minor storm event and underestimate capacity for the major storm event. From the UDFCD-CSU study of these inlets, the interception capacity is based on the depression and opening geometry.

WEIR PERFORMANCE DECAY:
 INLETS BECOME LESS EFFECTIVE IN WEIR FLOW AS THEY GROW IN LENGTH. WHAT THIS MEANS IS THAT ADDING INLETS TO REDUCE THE DEPTH OF FLOW WILL TYPICALLY NOT INCREASE TOTAL CAPACITY WHEN THE INLET IS IN WEIR FLOW. THIS IS IMPORTANT TO CONSIDER THIS WHEN DESIGNING FOR THE MINOR EVENT. IN AN EFFORT TO MEET MINOR EVENT DEPTH CRITERIA, THE SYSTEM MAY NEED TO BE EXTENDED FURTHER UPSTREAM.

The UDFCD-CSU study demonstrated a phenomenon referred to as weir performance decay, which is a function of the length of the inlet. It was found that inlets become less effective in weir flow as they grow in length, if the intent is to limit ponding to less than or equal to the curb height.

Photograph 3.4.2-1. Weir performance decay can be observed in this picture as flow appears to enter only the first two inlets while exceeding the height of the upstream curb.



From the UDFCD-CSU study, an empirical equation to estimate interception capacity for the CDOT Type R curb-opening inlet was developed and is shown in **Figure 3.4.2-1**.

The UDFCD-CSU study demonstrated that the grate and curb-opening function of combination inlets do not operate independently, but interfere with each other and affect the actual capacity of combination inlets. As such, the study demonstrated that the CDOT Type 13 combination inlets are also subject to weir

performance decay. Empirical equations to estimate interception capacity for the CDOT Type 13 combination inlet was developed and is shown in **Figure 3.4.2-2**.

Figure 3.4.2-1. CDOT Type R interception capacity in a sump

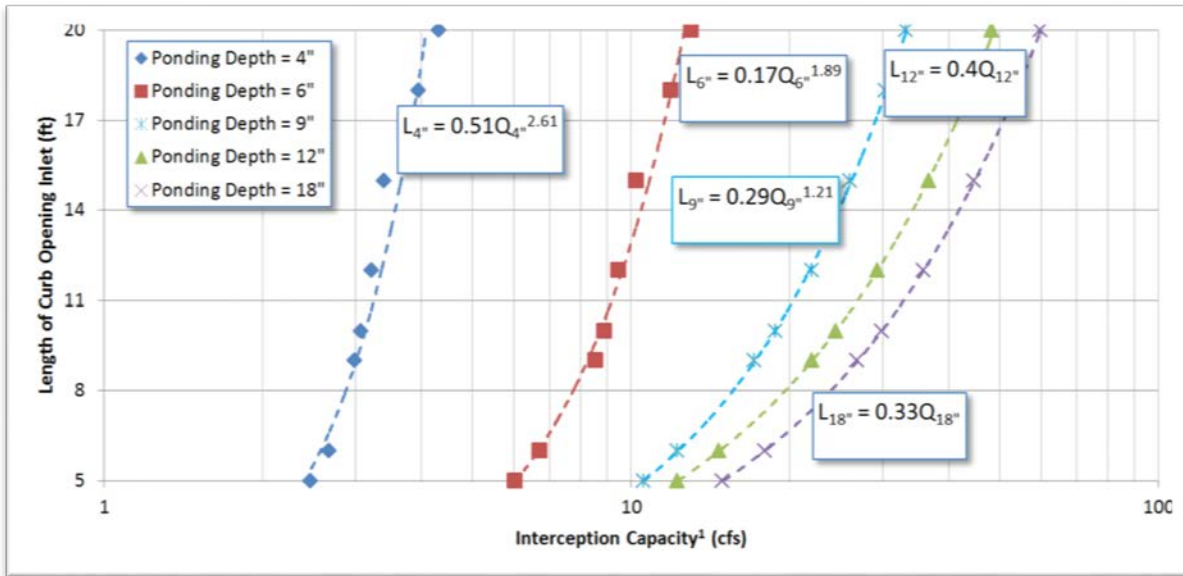
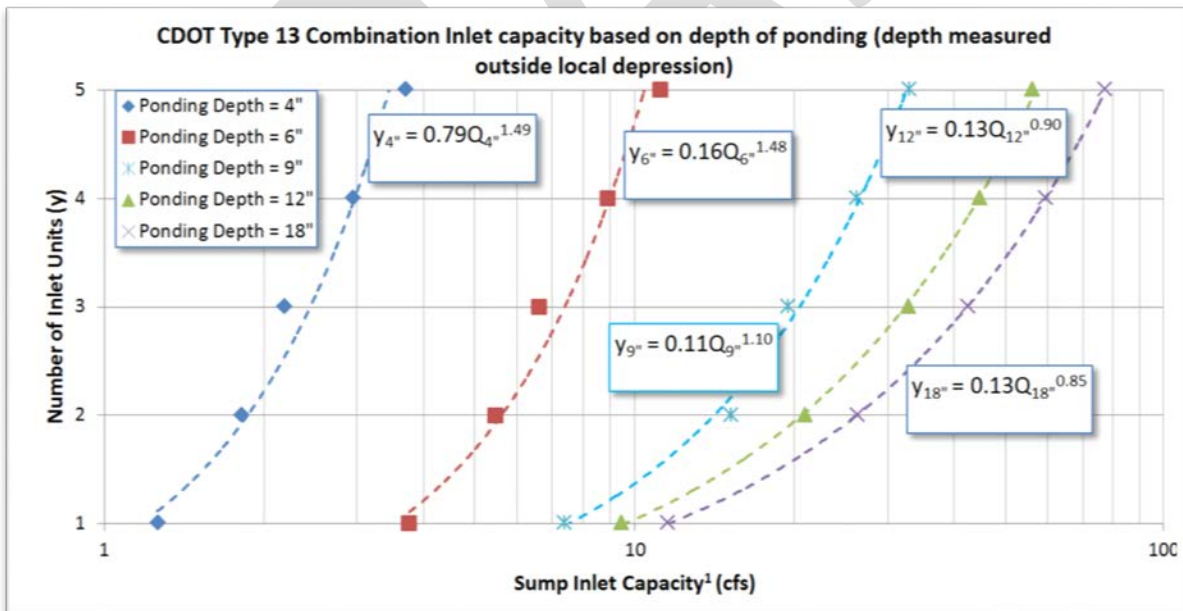

Figure 3.4.2-2. CDOT Type 13 Combination inlet interception capacity in a sump



3.4.3 Other Inlets in a Sump (Not Modeled in the UDFCD-CSU Study)

The hydraulic capacity of grate, curb-opening and slotted inlets operating as weirs is expressed as:

$$Q_i = C_w L_w d^{1.5} \quad \text{Equation 9-8}$$

Where:

- Q_i = inlet capacity, cfs
- C_w = weir discharge coefficient
- L_w = weir length, ft
- D = flow depth, ft

Values for C_w and L_w are presented in **Table 3.4.3-1** for various inlet types. Note that the expressions given for curb-opening inlets without depression should be used for depressed curb-opening inlets if $L > 12$ feet.

The hydraulic capacity of grate, curb-opening and slotted inlets operating as orifices is expressed as:

$$Q_i = C_o A_o (2gd)^{0.5} \quad \text{Equation 9-9}$$

Where:

- Q_i = inlet capacity, cfs
- C_o = orifice discharge coefficient
- A_o = orifice area, ft²
- d = characteristic depth as defined in **Table 3.4.3-1**, ft
- g = 32.2 ft/sec²

Values for C_o and A_o are presented in **Table 3.4.3-1** for different types of inlets.

Combination inlets are commonly used in sumps. The hydraulic capacity of combination inlets in sumps depends on the type of flow and the relative lengths of the curb opening and grate. For weir flow, the capacity of a combination inlet (grate length equal to the curb opening length) is equal to the capacity of the grate portion only. This is because the curb opening does not add any effective length to the weir. If the curb opening is longer than the grate, the capacity of the additional curb length should be added to the grate capacity. For orifice flow, the capacity of the curb opening should be added to the capacity of the grate.

Table 3.4.3-1. Sump Inlet Discharge Variables and Coefficients (Modified from Akan and Houghtalen 2002)

Inlet Type	C_w	L_w^1	Weir Equation Valid for	Definitions of Terms
Grate Inlet	3.00	$L+2W$	$d < 1.79(A_o/L_w)$	L = length of grate, ft W = width of grate, ft d = depth of water over grate, ft A_o = clear opening area ² , ft ²
Curb-Opening Inlet	3.00	L	$d < h$	L = length of curb opening, ft h = height of curb opening, ft $d = d_i - (h/2)$, ft d_i = depth of water at curb opening, ft
Depressed Curb-Opening Inlet ³	2.3	$L + 1.8W$	$d < (h + a)$	W = lateral width of depression, ft
Slotted Inlets	2.48	L	$d < 0.2$ ft	L = length of slot, ft d = depth at curb, ft

1. The weir length should be reduced where clogging is expected.
2. Ratio of clear opening area to total area is 0.8 for P-1-7/8-4 and reticuline grates, 0.9 for P-1-7/8 and 0.6 for P-1-1/8 grates. Curved vane and tilt bar grates are not recommended at sump locations unless in combination with curb openings.
3. If $L > 12$ ft, use the expressions for curb-opening inlets without depression.

Inlet Type	C_o	A_o^4	Orifice Equation Valid for	Definition of Terms
Grate Inlet	0.67	Clear opening area ⁵	$d > 1.79(AO/Lw)$	d = depth of water over grate, ft
Curb-Opening Inlet (depressed or undepressed, horizontal orifice throat)	0.67	$(h)(L)$	$d_i > 1.4h$	$d = d_i - (h/2)$, ft d_i = depth of water at curb opening, ft h = height of curb opening, ft
Slotted Inlet	0.80	$(L)(W)$	$d > 0.40$ ft	L = length of slot, ft W = width of slot, ft d = depth of water over slot, ft

4. The orifice area should be reduced where clogging is expected.
5. The ratio of clear opening area to total area is 0.8 for P-1-7/8-4 and reticuline grates, 0.9 for P-1-7/8 and 0.6 for P-1-1/8 grates. Curved vane and tilt bar grates are not recommended at sump locations unless in combination with curb openings.

3.4.4 Inlet Clogging

Inlets are subject to clogging effects (see **Photograph 3.4.4-1**). Selection of a clogging factor reflects the condition of debris and trash on the street. During a storm event, street inlets are usually loaded with debris by the first flush runoff volume. As a common practice for street drainage, 50% clogging is considered for the design of a single grate inlet and 10% clogging is considered for a single curb-opening inlet. Often, it takes multiple units to collect the stormwater on the street. Since the amount of debris is largely associated with the first flush volume in a storm event, the clogging factor applied to a multiple-unit street inlet should be decreased with respect to the length of the inlet. Linearly applying a single-unit clogging factor to a multiple-unit inlet will lead to an excessive increase in inlet length. For example, if a 50% clogging factor is applied to a six-unit inlet, the inlet would be presumed to function as a three-unit inlet. In reality, the upgradient units of the inlet would be more susceptible to clogging (perhaps at the 50% level) than the downgradient portions. In fact, continuously applying a 50% reduction to the discharge on the street will always leave 50% of the residual flow on the street. This means that the inlet will never reach a 100% capture and leads to unnecessarily long inlets.

Photograph 3.4.4-1. Clogging is an important consideration when designing inlets. With the concept of first-flush volume, the decay of clogging factor to grate or curb-opening length is described as (Guo 2000a):

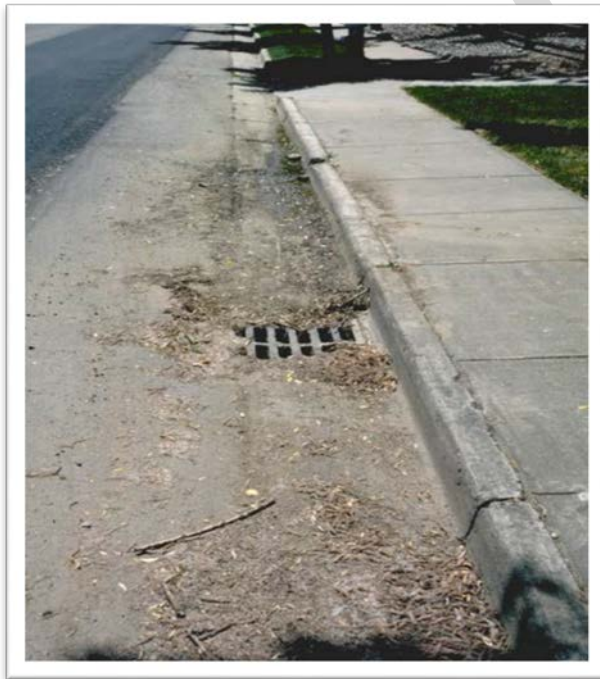

3.5 UD-Inlet Design Workbook

The UD-Inlet design workbook provides quick solutions for many of the street capacity and inlet performance computations described in this Chapter. A brief summary of each worksheet of the workbook is provided below. Note that some of the symbols and nomenclature in the worksheets do not correspond exactly with the nomenclature of the text. The text and the worksheets are computationally equivalent.

- The **Q-Peak** tab calculates the peak discharge for the inlet tributary area based on the Rational Method for the minor and major storm events. Alternatively, the user can enter a known flow. Information from this tab is exported to the *Inlet Management* tab.
- The **Inlet Management** tab imports information from the *Q-Peak* tab and *Inlet [#]* tabs and can be used to connect inlets in series so that bypass flow from an upstream inlet is added to flow

calculated for the next downstream inlet. This tab can also be used to modify design information imported from the *Q-Peak* tab.

- **Inlet [#]** tabs are created each time the user exports information from the *Q-Peak* tab to the *Inlet Management* tab. The *Inlet [#]* tabs calculate the allowable half-street capacity based on allowable depth and allowable spread for the minor and major storm events. This is also where the user selects an inlet type and calculates the capacity of that inlet.
- The **Inlet Pictures** tab contains a library of photographs of the various types of inlets contained in the worksheet and referenced in this Chapter.

[Reference:](http://www.udfed.org/software) The UD-Inlet design workbook, available for download at the www.udfed.org/software website is a common design tool used by Design Engineers and is accepted for use by FCU.

3.6 Nuisance Flows

The location of inlets is important to address the effects of nuisance flows and avoid icing. Nuisance flows are urban runoff flows that are typically most notable during dry weather and come from sources such as over-irrigation and snow melt. Nuisance flows can cause problems in both warm and cold weather months. Problems include algae growth and ice. While it is possible to minimize nuisance conditions through design, irrigation practices in the summer and snow and ice removal in the winter make it very difficult to eliminate nuisance flows entirely. Because these practices are somewhat controlled by residents and businesses; homeowner's associations and business associations should plan for maintenance on private roadways and parking areas to address nuisance flow conditions, particularly in the winter when ice accumulation can impede the ability of the drainage system to serve its purpose. Design Engineers should work with property owners and development teams to implement a storm drainage design that minimizes the impact of nuisance flows to the greatest degree possible. These include the maintenance objectives of removal of snow and ice promptly and frequently, keeping drains and gutters clear and placing shoveled snow onto lawns or grassy areas.

In the summer months, over-irrigation of lawns and landscaping can be a major contributor to nuisance flows. Car washing is another summertime cause of excess flows. In homes with poor or improper drainage, excessive sump pump discharge may also contribute.

Flows over sidewalks and driveways due to summertime nuisance flows can cause algae growth, especially if fertilizer is being used in conjunction with over-irrigation. Such algae growth is both a safety issue due to increased falling risk resulting from slippery surfaces and an aesthetic issue. Nuisance flows laden with fertilizer, sediment and other pollutants also have the potential to overload stormwater BMPs, which are generally designed for lower pollutant concentrations found in typical wet weather flows. Homeowners are required to direct downspout and sump pump discharges to swales, lawns and gardens (keeping away from foundation backfill zones) where water can infiltrate.

In winter months, snow and ice melt are the primary causes of nuisance flows and associated icing problems (see **Photograph 3.6-1**).

Photograph 3.6-1. The location of inlets is important to address the effects of nuisance flows.



Snow and ice melt can re-freeze on streets and sidewalks, where it poses hazards to the public and is difficult to remove. Often, icing is most significant on east-west streets that have less solar exposure in the winter. Trees, buildings, fences and topography can also create shady areas where ice accumulates. Snow and ice may also clog drains and inlets leading to flooding. Snowmelt has been found to have high pollutant concentrations which can stress water quality facilities. Because many of the issues related to winter nuisance flows are beyond the control of the City (especially in areas that are

already developed), identifying problem areas and incorporating maintenance objectives into the planning and design process is often the most effective practice for minimizing nuisance conditions. **Table 3.6-1** provides the various sources, problems and avoidance strategies associated with nuisance flows.

Table 3.6-1. Nuisance Flows: Sources, Problems and Avoidance Strategies

	Warm Weather	Cold Weather
Examples/Sources	<ul style="list-style-type: none"> • Over-irrigation of landscaping • Car washing • Sump pump discharge 	<ul style="list-style-type: none"> • Snow melt • Ice melt • Sump pump discharge
Problems	<ul style="list-style-type: none"> • Poor water quality • High-nutrient concentration • High-pollutant concentration • Algae growth 	<ul style="list-style-type: none"> • Icing leading to inlet blockage and flooding • Ice on streets and sidewalks • High-pollutant concentration
Avoidance Strategies	<ul style="list-style-type: none"> • Irrigation, drainage and fertilizer education • Proper drainage design • Minimization of directly connected impervious area • Sidewalk chase drains 	<ul style="list-style-type: none"> • Inlet, chase and sidewalk maintenance • Prompt and frequent snow and ice removal • Consider additional inlets in strategic locations • Shoveling snow onto grassy areas away from streets and inlets • Locate inlets and sumps away from shaded areas

Photograph 3.6-2. Inlets frequently need maintenance.



For new development projects, locating inlets in areas where water can be intercepted before it accumulates or slows down and has the opportunity to freeze is the most effective way to minimize icing from the design perspective. To the extent practical, locate inlets away from areas that will be heavily shaded during winter months (in particular the north side of buildings to help prevent ice build-up and allow proper flow. For areas where shading is unavoidable, consider providing additional inlet capacity at

strategic locations. For example, if a street with a southern exposure will drain to an east-west street that is shaded, having additional inlet capacity at the intersection may be advisable, especially if the flow is intended to turn and follow the east-west street. It is also important to consider potential future vegetative growth when evaluating shading effects. Although trees may be small and have little canopy when originally planted, they will grow and ultimately provide far greater tree canopy than when initially planted. Tree canopy may vary seasonally; depending on the tree species (e.g. deciduous trees

lose their leaves in the fall and less canopy is present in the winter). Ultimately, even with careful placement of inlets and avoidance of shading to the extent practical, icing in some locations will likely occur due to shading from buildings, fences and other improvements on private property and maintenance to remove accumulated ice will be necessary.

CITY OF FORT COLLINS POLICY ON THE USE OF SUMP PUMPS:

- DISCHARGE FROM FOUNDATION DRAINS, PRIVATE LOT STORM DRAINAGE PIPES AND SUMP PUMPS MUST COMPLY WITH ALL APPLICABLE STATE AND LOCAL REQUIREMENTS. CITY CODE, SECTION 26-214 STATES THAT STORMWATER AND ALL OTHER UNPOLLUTED DRAINAGE WATER SHALL ONLY BE DISCHARGED TO SUCH STORMWATER FACILITIES AS ARE SPECIFICALLY AUTHORIZED FOR SUCH DISCHARGE BY THE UTILITIES EXECUTIVE DIRECTOR, PROVIDED HOWEVER, THAT IN NO EVENT SHALL NON-STORMWATER RUNOFF (WHICH INCLUDES LANDSCAPE IRRIGATION, UNCONTAMINATED PUMPED, INFILTRATED OR RISING GROUND WATER, AND FLOWS FROM PROPERLY INSTALLED, OPERATED AND CITY-APPROVED FOOTING, FOUNDATION OR CRAWL SPACE DRAIN OR PUMP) OR WATER FROM NATURAL SPRINGS BE PERMITTED TO BE DISCHARGED ONTO OR UPON ANY STREET, SIDEWALK OR GUTTER. ADDITIONALLY, CITY CODE, SECTION 26-498 PROHIBITS CONNECTIONS TO A STORM DRAINAGE FACILITY TO CONVEY FLOWS OTHER THAN STORM DRAINAGE AND UNCONTAMINATED GROUNDWATER FLOWS.
- DISCHARGE FROM SUMP PUMPS MAY BE TIED TO THE CITY'S STORMWATER SYSTEM UPON APPROVAL FROM THE UTILITIES EXECUTIVE DIRECTOR, BUT MAY NOT DISCHARGE DIRECTLY TO A STREET SURFACE. ALL TIE-IN POINTS MUST BE INSTALLED AT APPROVED LOCATIONS SUCH AS AT A MANHOLE OR AT AN INLET. NO DIRECT TIE-IN TO A STORM DRAIN PIPE WILL BE ALLOWED. SUMP PUMP DISCHARGE FLOWS CAN ONLY BE RELEASED INTO A STORMWATER CONVEYANCE SYSTEM (SUCH AS PIPE JUNCTIONS, CHANNELS OR PONDS) SPECIFICALLY DESIGNED AND APPROVED BY THE CITY TO ACCEPT SUCH DISCHARGE.
- PLEASE REFER TO CITY CODE SECTIONS 26-214, 26-331, 26-491 AND 26-498 FOR FURTHER GUIDANCE.

Control of nuisance waters such as shallow ponding that occasionally concentrate on flat lawns, landscaped, paved or other such areas is strictly the responsibility of the property owner of the land where ponding occurs. The City will make reasonable efforts to minimize the occurrence of such nuisances through its review and inspection authorities, but if such nuisances do occur, the City is not responsible or obligated to correct or require any other party to correct such a problem.

4.0 Storm Drain Systems

For more information on nuisance flows, multiple Colorado-based publications are available to provide guidance related to landscape management practices and snow and ice removal. Representative resources include:

- UDFCD Manual, Volume 3, Source Control BMPs
- GreenCO BMP Manual
- Colorado State University Extension Yard and Garden Fact Sheets

4.0 Storm Drain Systems

4.1 Introduction

Once stormwater is collected from the street by an inlet, it is directed into the storm drain system. The storm drain system is comprised of inlets, pipes, manholes, outlets and other appurtenances. For specific information regarding the applicability of a number of available pipe materials, a document titled “Storm Sewer Pipe Material Technical Memorandum” is available for download at www.udfcd.org

Apart from inlets, manholes are the most common appurtenance in storm drain systems. Their primary functions include:

- Providing maintenance access
- Serving as junctions when two or more pipes merge
- Providing flow transitions for changes in pipe size, slope and alignment
- Providing ventilation

Manholes are generally made of precast or cast-in-place reinforced concrete. They are typically 48 inches (48”) or 60 inches (60”) in diameter depending on the pipe size and orientation. Manholes are required at regular intervals for maintenance requirements. Maximum spacing of 400’ is required, even along straight sections of piping. Standard size

STORM SYSTEM MANHOLES:

- REQUIRED TO BE PLACED AT ALL JUNCTIONS, INTERSECTIONS, CHANGE IN PIPE DIAMETER AND CHANGE IN SLOPE
- MUST BE PLACED AT 400’ MAX SPACING, EVEN ALONG STRAIGHT SECTIONS
- INVERT DROPS IN MANHOLES SHOULD BE 0.1’ WHEREVER POSSIBLE
- MAXIMUM VELOCITY OF 20 FPS THROUGH STORM SYSTEMS
- OUTLET TRANSITIONS (I.E. FLARED-END SECTIONS) ARE REQUIRED FOR TRANSITIONS FROM PIPE TO OPEN CHANNEL FLOW TO REDUCE VELOCITY AND EROSION.

manholes cannot accommodate large pipes, so special junction vaults are constructed for that application.

Outlet structures are transitions from pipe flow to open channel flow or still water (e.g. ponds, lakes, etc.). Their primary function is to provide a transition that minimizes erosion and controls flow rates into the receiving water body. Occasionally, flap gates or other types of check valves are placed on outlet structures to prevent backflow from high tailwater or flood-prone receiving waters.

Reference: FCU requires that the construction of all stormwater facilities must be built in accordance the Development Construction Standards for Water, Wastewater and Stormwater.

4.2 Easements for Storm Pipes

Required minimum widths of drainage easements for common types of drainage facilities are listed in Table 4.2-1.

Table 4.2-1: Required Drainage Easements for Pipes

Drainage Facility:	Minimum Easement Width
Storm Sewer Pipe Diameter < 36"	
Depth to Invert < 5'	20'
5' < Depth to Invert ≤ 10'	30'
Depth to Invert > 10'	30' minimum or [Pipe I.D. + 6 + Depth x 2]
Storm Sewer Pipe Diameter ≥ 36"	
Depth to Invert < 5'	20' minimum or [Pipe I.D. + 7 + Depth x 2]
5' < Depth to Invert ≤ 10'	30' minimum or [Pipe I.D. + 7 + Depth x 2]
Depth to Invert > 10'	[Pipe I.D. + 7 + Depth x 2]

4.3 Design Process, Considerations and Constraints

The design of a storm drain system requires a large data collection effort. The data requirements in the proposed service area include topography, drainage boundaries, imperviousness, soil types and locations of any existing storm drain conduits, inlets and manholes. In addition, identification of the type and location of other utilities in the ground is critical. Alternative layouts of a new system (or modifications to an existing system) can be investigated using these data.

System layouts rely largely on street rights-of-way and topography. Most layouts are dendritic (tree) networks that follow the street pattern. Dendritic networks collect stormwater from a broad area and converge in the downstream direction. Networks with parallel branches are possible but

sometimes less desirable. Each layout should depict inlet and manhole locations, drainage boundaries services by the inlets, pipe locations, flow direction and outlet locations. A final layout selection is made from the viable alternatives based on likely system performance and cost.

STORM PIPES IN THE RIGHT-OF-WAY:

- MINIMUM DIAMETER IS 15" OR EQUIVALENT.
- NEW INLET/PIPE SYSTEMS AND STREETS TO BE SIZED TO CONVEY THE 100-YEAR STORM.
- PIPELINE HGL AND EGL TO BE A MINIMUM OF 12" BELOW THE SURFACE.

Once a final layout is chosen, storm drain pipes are sized based on the hydrology (peak flows) and hydraulics (pipe capacities). This is accomplished by designing the upstream pipes first and moving downstream. Pipe diameters less than 15 inches (15") are not recommended for storm drains. The City requires that the minimum pipe diameter for public storm pipes and all pipes located in the public right-of-way is 15 inches (15"), or a minimum vertical dimension of twelve inches (12") if elliptical or arch pipe is used.

Pipes generally increase in size moving downstream since the drainage area (and thus flow) is increasing. Downstream pipes should never be smaller than upstream pipes, even if a steeper slope is encountered that will provide sufficient capacity with a smaller pipe. The potential for clogging at the resulting "choke point" is always a concern.

Storm pipes are typically sized to convey the minor storm without surcharging; using open channel hydraulics calculations to determine normal depth 100% full pipe depth. However, storm pipes need to be sized for the full amount of stormwater that is able to reach the pipes from inlets or other appurtenances. For example, if an inlet is able to convey 20 cfs to the storm piping system during the 100-year storm, then the pipes need to be sized to safely convey the 20 cfs while keeping the HGL and EGL below the surface of the roadway.

Because the maximum capacity of a circular pipe occurs at approximately 93% of the depth of full pipe flow, designing for full flow results in a slightly conservative design. FCU requires that the combination of storm piping systems and streets are required to accommodate the major storm without exceeding encroachment standards or hydraulic/energy grade line requirements as set forth in this Manual.

Manholes are located in the system in conjunction with pipe sizing and inlet placement, where manhole locations are dictated by standard design practices. For example, manholes are required whenever there is a lateral pipe servicing an inlet, and where a change occurs in pipe size, alignment, or slope. In addition, manholes are required at pipe branch junctions. Manholes are also required along long straight section of pipe for maintenance purposes, with the distance between manholes dependent on

4.0 Storm Drain Systems

pipe size, but not more than 400 feet. Whenever possible, the invert of a pipe leaving a manhole should be at least 0.1 foot lower than the incoming pipe to ensure positive flow flows through the manhole. However, FCU allows for 0 foot drop across the inlet or manhole when a 0.1 foot drop is not possible. Whenever possible, match the pipe soffit elevations when the downstream pipe is larger to minimize backwater effects on the upstream pipe. Additional manholes may be necessary to “step down” a steep grade, allowing pipe slopes to be much flatter than the slope of the street above. This is done to prevent velocities in storm drain pipes from exceeding the recommended maximum velocity of 20 fps.

Once storm drain pipes are sized and manhole locations are determined, the performance of the storm drain system must be evaluated using energy grade line (EGL) calculations starting at the downstream system outlet. As stormwater flows through the storm drain system, it encounters many flow transitions. These transitions include changes in pipe size, slope and alignment, as well as entrance and exit conditions. All of these transitions consume energy, resulting in energy losses expressed as head losses. These losses must be accounted for to ensure that inlets and manholes do not surcharge to a significant degree (i.e. produce street flooding). This is accomplished using hydraulic grade line (HGL) calculations as a check on pipe sizes and system losses. If significant surcharging occurs, the pipe sizes should be increased. High tail water conditions at the storm drain outlet may also produce surcharging. This can also be accounted for using HGL calculations.

FCU requires that if HGL is surcharged along the pipe, the EGL will need to be determined and shown on the design plans to ensure that the EGL does not elevate above the finished surface. FCU requires that the EGL is a minimum of twelve inches (12”) below the manhole lid elevation and/or flowline elevation at the inlet. Bolt-down lids are not allowed except by variance. This requirement applies to both public and private storm drainage systems.

4.4 Storm Drain Hydrology and Hydraulics

The Streets, Inlets and Storm Drains chapter in the UDFCD Manual provides a comprehensive section on the hydraulic design for pipe systems, the details of which are not included in this Manual. The UD-Culvert and UD-Sewer software downloads are available at www.udfcd.org are common tools used to properly size culverts and pipe systems. Bentley Flowmaster and other pipe calculator software’s are also accepted for use by FCU. Care must be taken by the Design Engineer use the proper loss coefficients for input into the software. The methodology behind determining the proper loss coefficients are provided in this same chapter of the UDFCM Manual.

The depth of flow in the receiving stream must be taken into consideration for backwater computations for both the minor and major storm runoff. An analysis of the joint probability of occurrence may be warranted based on the standards described below. FEMA recommends modeling a 10-year water surface in the receiving stream for a 100-year tributary discharge. HEC-22 also provides guidance based on the ratio of main stream watershed area to that of the tributary stream. FCU follows FEMA recommended standards for hydraulic modeling tie-in to the following waterways:

- Poudre River – 2-year water surface elevation

- Spring Creek – 10-year water surface elevation

Backwater hydraulics analysis for storm pipe systems entering detention basins:

- Shall be based upon the 100-year water surface elevation in the detention basin or the emergency spillway elevation if that is higher. Alternatively, if a SWMM model is prepared for the site, it may be utilized in sizing the storm pipes.
- Storm pipe systems (including roof drains and underdrains) entering detention basins are required to enter at the bottom elevation of that area of the basin and are not allowed to enter at a higher elevation due to erosion issues

Backwater hydraulics analysis for storm pipe systems entering irrigation ditches:

- Shall be based upon the normal operating water surface elevation (as determined by the irrigation ditch or reservoir company). It is typical, however, for the irrigation ditch or reservoir company to require storm pipe tie-ins above the normal operating water surface elevation and/or include flap gates at the outfall. Specific approvals and coordination would need to be conducted with the irrigation ditch or reservoir company for this circumstance.

Figure 4.4.1-1. Hydraulic and Energy Grade Lines

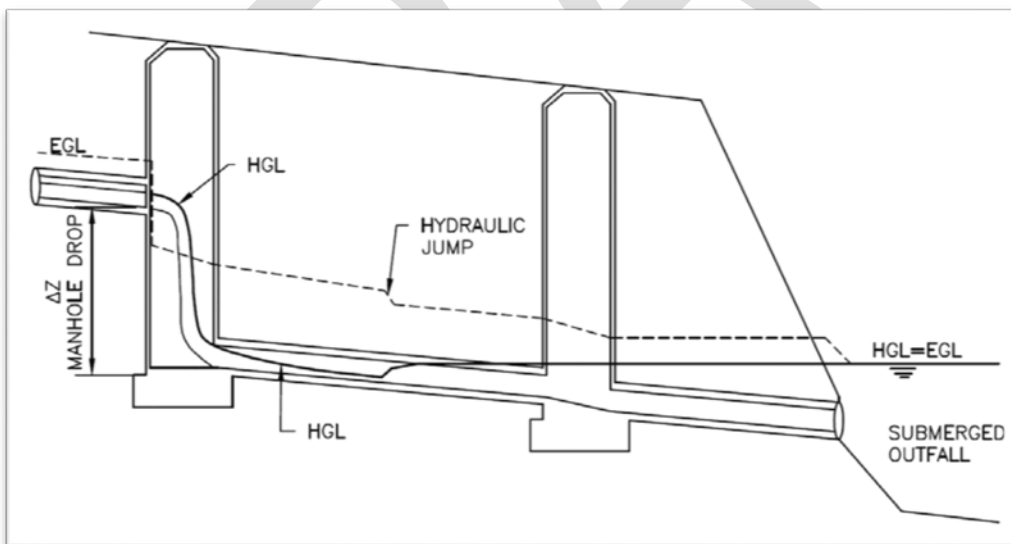

5.0 Swales

The functions and benefits from natural streams can be extended further upstream in the watershed by conveying runoff on the surface in vegetated channels and swales rather than in underground storm

drains. Besides the aesthetic and habitat value of surface channels, stormwater quality can be enhanced by promoting beneficial interaction between water, soil and vegetation. Conveyance in storm drains produces no such interactions or water quality enhancement.

Guidance is provided in this subsection for the design of swales, draining areas from less than an acre up to about 10 impervious acres (e.g. 20 acres at 50% imperviousness). A series of design charts are provided to guide the designer in determining stable conditions in vegetated or void-filled riprap swales of varying cross-sections based on design flow rate and slope. The charts show flow rates as high as 100 cfs (stable at relatively flat slopes) and slopes as steep as ten percent (10%) (stable at relatively low flows). It should be noted that the design criteria in this section differs from those in Chapter 7: Water Quality, of this Manual. Those criteria are intended to provide a higher level of water quality treatment. These criteria are intended for stable conveyance more so than water quality benefits.

5.1 Design Criteria for Swales

All open channels shall be designed with freeboard. Freeboard for major channels (defined as those with capacity in excess of one hundred (100) cfs) must be a minimum of one foot (1') of extra depth. Freeboard for minor channels (defined as those carrying less than one hundred (100) cfs design flow) must be designed to handle a minimum of an additional 33 percent of runoff, over and above the 100-year design flow.

Design criteria are described for grass and rock (soil riprap or void-filled riprap) swales. Where indicated by **Figures 5.1.1-1** through **5.1.1-4**, grass swales meeting these criteria are preferred, but when conditions require, swales lined with soil riprap or void-filled riprap are advisable. When designing grass-lined swales, a Froude No. ≤ 0.8 is required.

In order to maximize the use of grass swales, and increase the likelihood that the swale will remain functional and stable over time, two key design principles should be considered.

- 1) **Adopt shallow swale section with flat bottom.** Swale cross-sections that allow runoff to spread out (shallow, flat bottom with gentle side slopes) promote lower velocities and shear stresses than triangular (or "V" shaped) swales. This is also good for water quality. In general, the wider the bottom width of the swale, the more stable it will be, although concentrated flow paths may still form. It is generally recommended that swales be of a trapezoidal shape with a bottom width of 2 feet or more with side slopes that are 5:1 or flatter.
- 2) **Establish dense turf-forming grass in suitable soils.** The single most important factor in creating stable grass swales is to establish a dense stand of turf-forming grass in the bottom and side slopes of the swale. This requires good soils or amendments and proper soil

preparation and planting. Irrigation may also be necessary. See Chapter 4: Construction Control Measures, for more information.

5.1.1 Stability Charts

Swale stability based on slope, flow rate, swale geometry and grass or rock lining are shown graphically in **Figures 5.1.1-1** through **5.1.1-4**. Design guidance is provided in the stability charts for design discharges up to 100 cfs for longitudinal slopes up to ten percent (10%). Although these figures go up to 100 cfs, it may be appropriate to design a more naturalized channel section for flow rates greater than 30 or 40 cfs. This is largely dependent on site-specific considerations. As already mentioned, steep swales are most feasible for small discharges while swales carrying large discharges are most feasible at flatter slopes. If the chart is indicating that riprap greater than Type H (see **Figure 5.1.1-3**) is required, a swale for those hydraulic conditions will not be allowed. Typically, if Type H riprap is shown to be required, other design options such as widening the swale or flattening the slope must be explored.

The use of **Figures 5.1.1-1** through **5.1.1-4** for swale stability analysis requires that geometric parameters indicated at the top of each chart apply and the requirements of Section 5.2 for grass swales and Section 5.3 for soil riprap or void-filled riprap are met.

Table 5.1-1 below summarizes the appropriate stability chart to reference based upon the swale geometry.

Table 5.1-1. Summary of swale properties for stability chart reference

Bottom Width	Side Slope	Stability Chart
2-4 feet	Between 5:1 and 10:1	Figure 5.1.1-1
2-4 feet	10:1 or flatter	Figure 5.1.1-2
Greater than 4 feet	Between 5:1 and 10:1	Figure 5.1.1-3
Greater than 4 feet	10:1 or flatter	Figure 5.1.1-4

For swales outside the range of application of **Figures 5.1.1-1** through **5.1.1-4**, specific analysis of the proposed swale parameters may be required.

5.2 Grass Swales

5.2.1 Soil and Vegetation Properties

The single most important factor governing the stability of grass swales is the quality of vegetation. Chapter 4: Construction Control Measures provides recommended seed mixes when specific seed mixes are not provided in the Landscape Plans. Turf-forming grasses that include a variety of species work best.

In addition to seeding, it is recommended that grass plugs of the dominant species in the seed mix be planted to provide some immediate vegetative cover and improve overall establishment. Place drier species on the side slopes. Placing sod is also an option for grass swales.

5.2.2 Construction

It is imperative that the construction drawings and specifications address seedbed preparation; installation of seed, blankets and plugs; temporary irrigation; weed control; and follow-up reseeding and maintenance. Specific construction recommendations, including for submittals and inspections, can be found in Chapter 4: Construction Control Measures. Good temporary erosion controls are critical during establishment of vegetation.

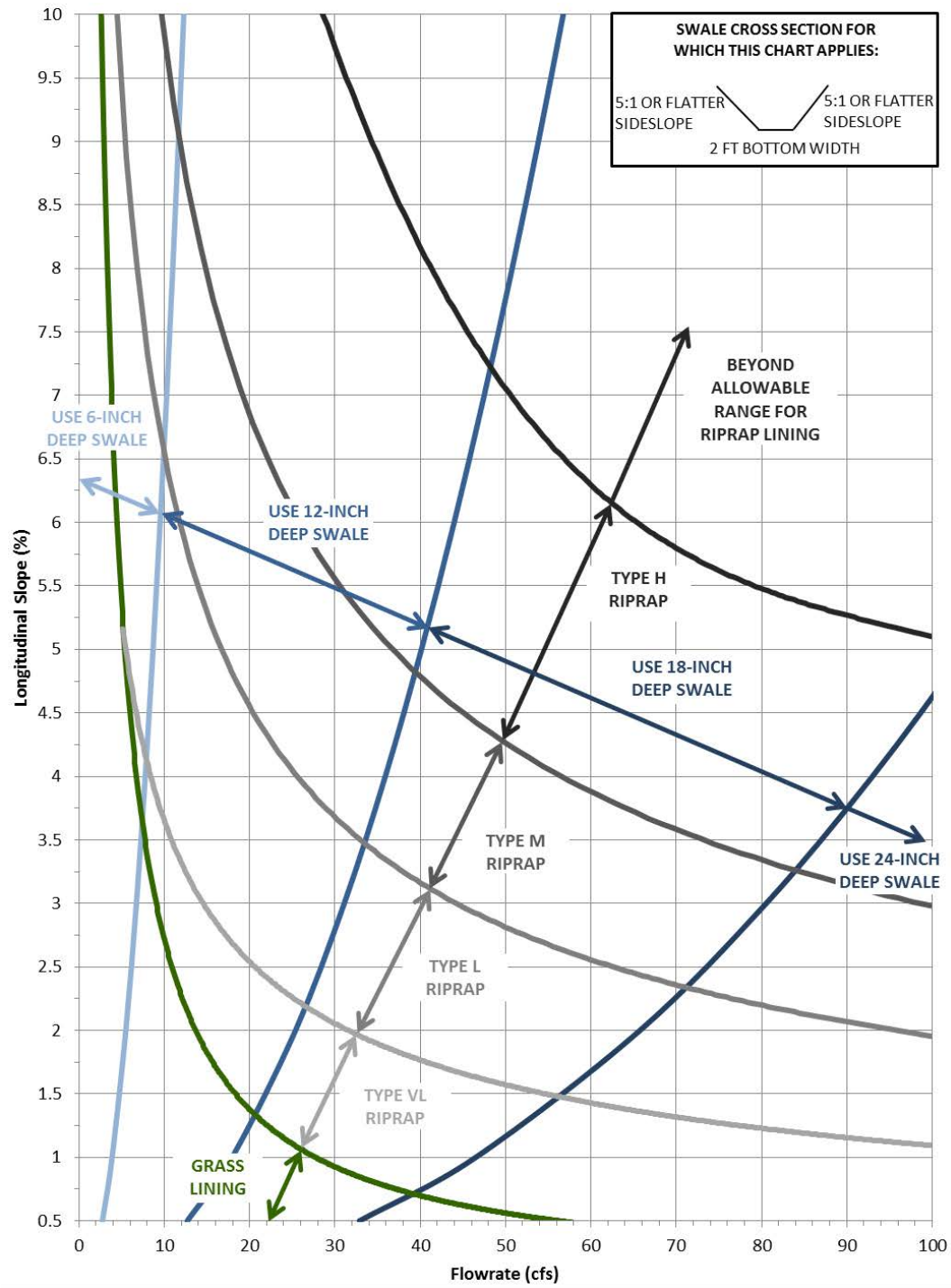

Figure 5.1.1-1. Swale stability chart; 2-4 foot bottom width and side slopes between 5:1 and 10:1
 (Note: Riprap classifications refer to gradation for riprap used in soil riprap or void-filled riprap. See Figure 8-34 for gradations.) (Source: Muller Engineering Company)

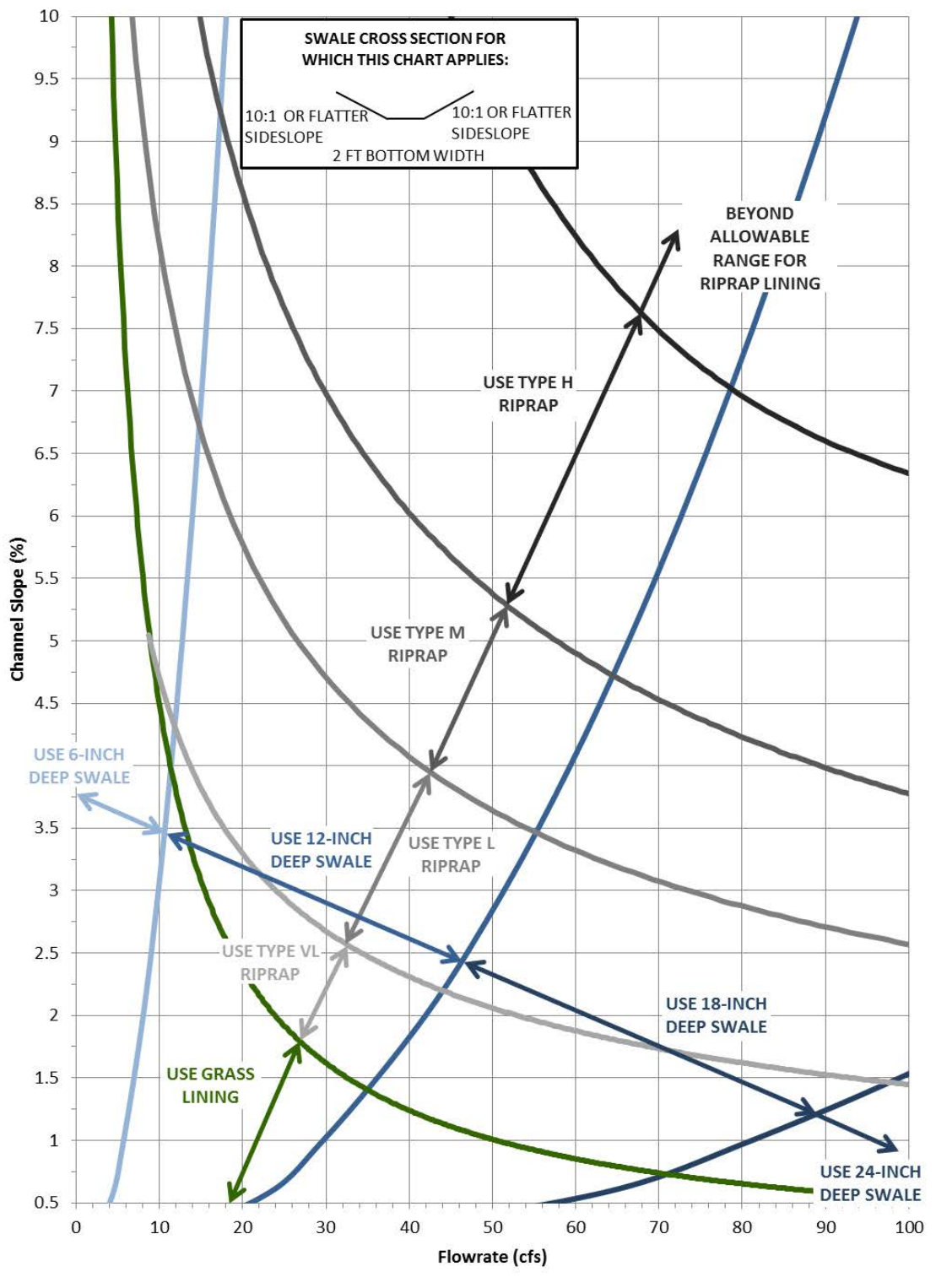

Figure 5.1.1-2. Swale stability chart; 2-4 foot bottom width and 10:1 (or flatter) side slopes
 (Note: Riprap classifications refer to gradation for riprap used in soil riprap or void-filled riprap. See Figure 8-34 for gradations.) (Source: Muller Engineering Company)

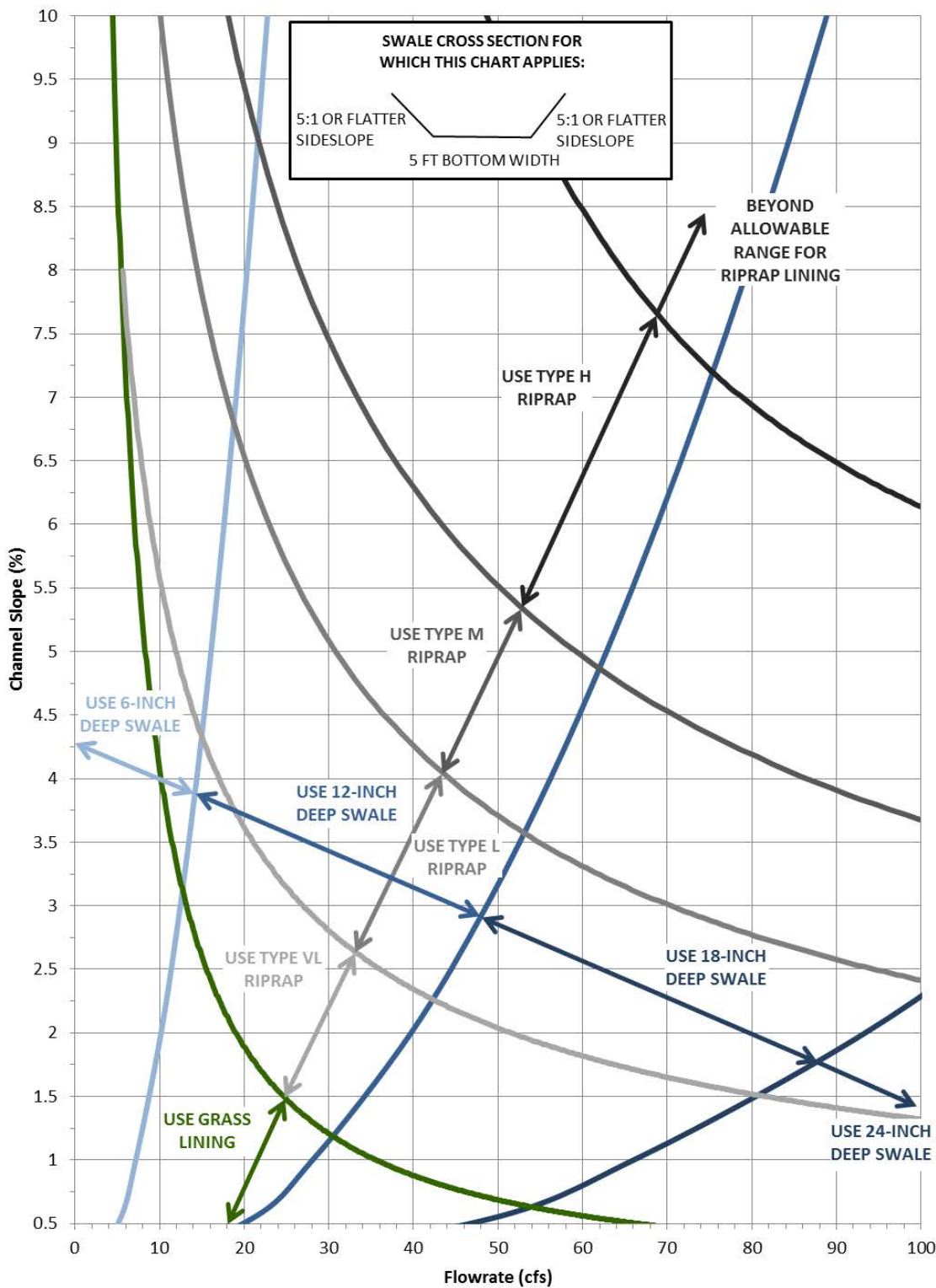

Figure 5.1.1-3. Swale stability chart; greater than 4 foot bottom width and side slopes between 5:1 and 10:1

(Note: Riprap classifications refer to gradation for riprap used in soil riprap or void-filled riprap. See Figure 8-34 for gradations.) (Source: Muller Engineering Company)

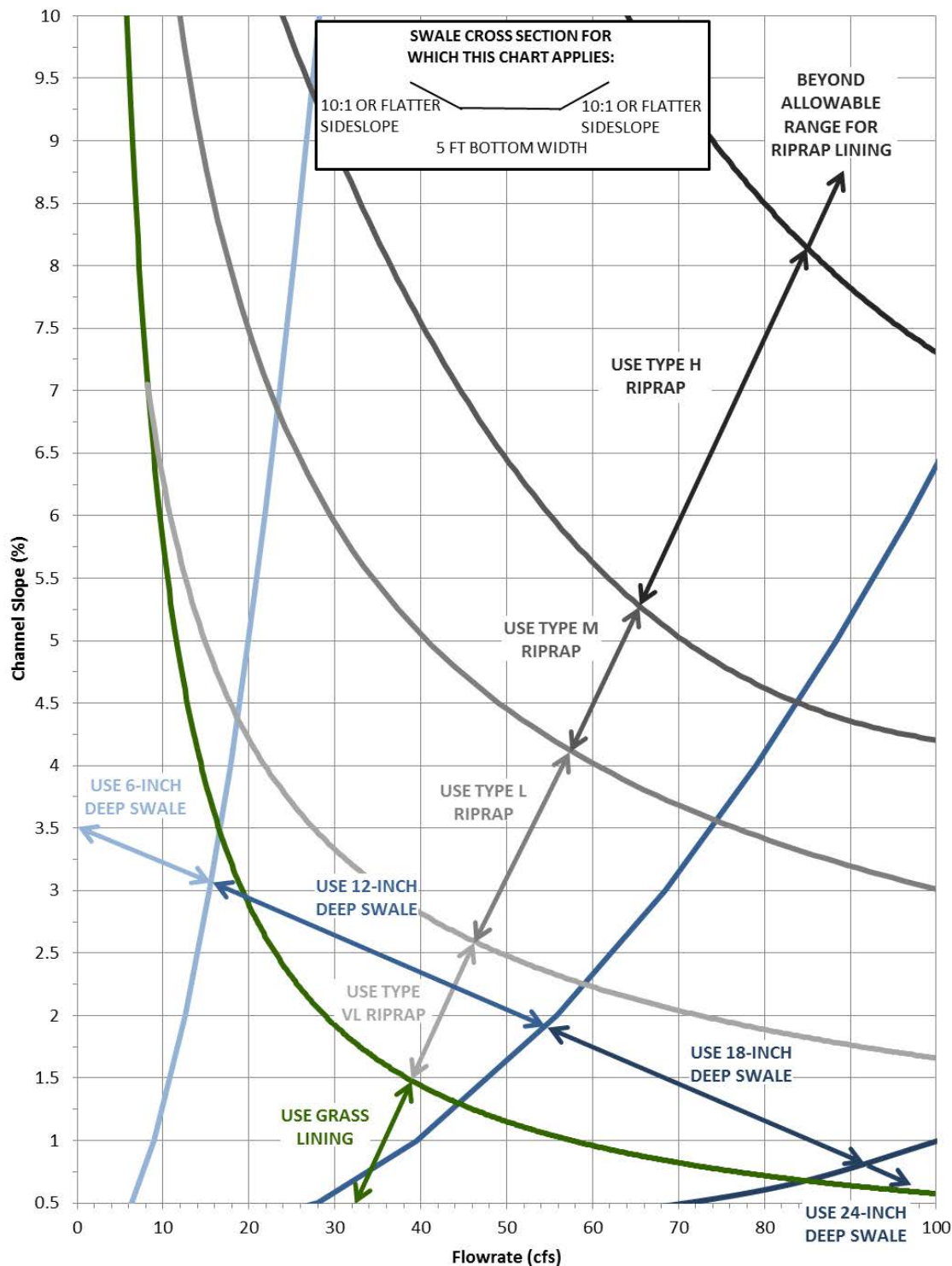

Figure 5.1.1-4. Swale stability chart; greater than 4 foot width and 10:1 (or flatter) side slopes
 (Note: Riprap classifications refer to gradation for riprap used in soil riprap or void-filled riprap. See Figure 8-34 for gradations.) (Source: Muller Engineering Company)

6.0 Use of Irrigation Ditches

The use of irrigation ditches for stormwater conveyance or outfall purposes must be in accordance with the policy discussed in Chapter 1: Drainage Principles and Policies.

FCU requires the appropriate owner's / ditch and reservoir company's approval, whether public or private if improvements cause any of the following:

- 1) Alteration of the existing patterns of drainage into irrigation ditches
- 2) Increased volumes discharged into the ditch
- 3) Changes in the quality of runoff entering the ditch
- 4) Change in the historic point of discharge into the ditch
- 5) Any proposed ditch crossing(s) or relocation(s)
- 6) Any proposed grading within the ditch easement
- 7) Access to the ditch easement during construction activities

This approval may be in the form of signature on the construction plans or documents. If determined by the Utilities Executive Director to be sufficient, other formal legal agreements may be substituted for an approval signature on the construction plans. The list above is not exhaustive and represents examples of circumstances when ditch or reservoir company approval is required. Early contact with affected companies may be beneficial.

In the rare instance where an irrigation ditch is allowed to serve as the outfall for a stormwater facility the following provisions, at a minimum, must be met:

- 1) The maximum water surface elevation must be determined based on the maximum amount of irrigation flow in the ditch. The appropriate owner / ditch or reservoir company is the determining authority in regard to the maximum irrigation flow in the ditch. Written verification of the maximum irrigation flow from the owner / ditch or reservoir company must be submitted with the hydraulic analysis of the ditch water surface elevation.
- 2) The maximum water surface elevation of the ditch must then be determined by combining the maximum irrigation flow in the ditch with the 100-year stormwater flows in the ditch.
- 3) The detention outlet must be designed such that backflow from the ditch into the detention facility is prevented.

7.0 Energy Dissipation and Erosion Protection

- 4) The backwater effects caused by the design of a detention outlet, if any, must be reviewed and approved by both FCU and the appropriate ditch or reservoir company.
- 5) The outlet design must consider tailwater effects on the outlet pipe resulting from the combination of the maximum irrigation flow and the 100-year storm discharge within the ditch.
- 6) The 100-year water surface elevation of the ditch must be determined using the appropriate Master Drainage Plan or if not available, additional studies may be required from the party seeking to discharge into the ditch. For cases where 100-year discharges are not available, upstream restrictions or structure capacities can be considered for determining ditch flows.

If new developments are adjacent to irrigation facilities but no flows are being directed into the ditch, the owner/ ditch or reservoir company must still be notified of the proposed development. In such cases, ditch or reservoir company approval shall be required prior to any approval by FCU, unless upon written request by the applicant, the Utilities Executive Director determines that the development will result in no impact on or to the ditch or reservoir company and that there will be no impact on stormwater flows or improvements from the adjacent irrigation facilities.

The party seeking modifications to existing ditch conditions must obtain the appropriate owner / ditch or reservoir company approvals and signatures prior to seeking FCU approval for such modifications.

When privately owned and maintained irrigation facilities abut private property, it is the responsibility of the private parties involved to develop and implement a policy regarding safety.

7.0 Energy Dissipation and Erosion Protection

Local scour is typified by a scour hole produced at a pipe or culvert outlet. This is the result of high exit velocities, and the effects extend only a limited distance downstream. Coarse material scoured from the circular or elongated hole is deposited immediately downstream, often forming a low bar. Finer material is transported farther downstream. The dimensions of the scour hole change due to sedimentation during low flows and the varying erosive effects of storm events. The scour hole is generally deepest during passage of the peak flow.

Protection against scour at outlets ranges from limited riprap placement to complex and expensive energy dissipation devices. Pre-formed scour holes (approximating the configuration of naturally formed holes) dissipate energy while providing a protective lining to the streambed.

This section addresses energy dissipation and erosion control utilizing riprap and other measures that can be used to minimize or eliminate local scour at a pipe outlet. In general, these measures may pose risks to the public. Discourage public access and minimize the risk of falls at these structures.

7.0 Energy Dissipation and Erosion Protection

Scour and Stream Degradation: Scour is typically found at culvert outlets and other isolated transitional areas within a stream. Frequently, scour holes fill in with sediment over time only to be reformed during infrequent high flows. Degradation is a phenomenon that is independent of culvert performance. Natural causes can produce a lowering of the streambed over time. Contributing factors include the slope of the stream and the size and availability of the sediment load. Degradation can also be a result of other constructed features such as upstream detention or increased watershed imperviousness. The identification of a degrading stream is an essential part of the original site investigation.

[Reference:](#) [Methods for predicting scour hole dimensions are found in the Hydraulic Design of Energy Dissipators for Culverts and Channels \(FHWA 1983 and 2000\).](#)

7.1 Use of Riprap Policy

Riprap should only be used when other methods of protection or stabilization are not appropriate or possible. Alternatives to riprap are generally recommended:

- Manufactured channel lining or revetment treatments such as Turf Reinforcement Mats (TRMs)
- Erosion control matting
- Geotextiles
- Articulating Concrete Blocks (ACBs)
- Other flexible linings

These alternates will be considered by FCU on a case-by-case basis in order to determine the most appropriate material that should be specified under particular conditions and for different applications.

When riprap is determined to be the best or only appropriate method for stabilization soil riprap may be utilized. Soil riprap is intended for use in applications where vegetative cover can be established in the riprap.

- FCU requires that four to six inches (4-6") of topsoil on top of soil riprap is required to help establish vegetation.
- FCU requires that the minimum d_{50} (mean particle size intermediate dimension) by weight for riprap, is twelve inches (12"), or Type M riprap.

Gabions are not allowed.

7.2 Riprap Apron

This section addresses the use of riprap for erosion protection downstream of conduit and culvert outlets.

The length of the riprap protection downstream from the outlet depends on the degree of protection desired. If it is necessary to prevent all erosion, the riprap must be continued until the velocity has been reduced to an acceptable value. The acceptable major event velocity is set at five feet per second (5 fps) for non-cohesive soils and at seven feet per second (7 fps) for erosion resistant soils. The rate at which the velocity of a jet from a conduit outlet decreases is not well known. For the procedure recommended here, it is assumed to be related to the angle of lateral expansion, θ , of the jet. The velocity is related to the expansion factor, $(1/(2\tan\theta))$, which can be determined directly using **Figure 7.2-2 or 7.2-3**, by assuming that the expanding jet has a rectangular shape:

$$L_p = \left(\frac{1}{2 \tan \theta} \right) \left(\frac{A_t}{Y_t} - W \right) \quad \text{Equation 9-10}$$

Where:

L_p = length of protection, ft

W = width of the conduit (ft, use diameter for circular conduits)

Y_t = tailwater depth, ft

θ = the expansion angle of the culvert flow

And:

$$A_t = \frac{Q}{v} \quad \text{Equation 9-11}$$

Where:

Q = design discharge, cfs

v = the allowable non-eroding velocity in the downstream channel, fps

A_t = required area of flow at the allowable velocity, ft²

In no case should L_p be less than 3H or 3D, nor does L_p need to be greater than 10H or 10D whenever the Froude parameter, $Q/WH^{1.5}$ or $Q/D^{2.5}$ is less than 8.0 or 6.0, respectively. Whenever the Froude parameter is greater than these maximums, increase the maximum L_p required by $1/4D_c$ or $1/4H$ for circular or rectangular culverts, respectively, for each whole number by which the Froude parameter is greater than 8.0 or 6.0, respectively.

Once L_p has been determined, the width of the riprap protection at the furthest downstream point should be verified. This dimension is labeled "T" on **Figure 7.2-1**. The first step is to solve for θ using the results from **Figure 7.2-2 or 7.2-3**.

$$\theta = \tan^{-1} \left(\frac{1}{2(\text{ExpansionFactor})} \right) \quad \text{Equation 9-12}$$

Where:

Expansion Factor = determined using **Figure 7.2-2** or **7.2-3**

T is then calculated using the following equation:

$$T = 2(L_p \tan \theta) + W \quad \text{Equation 9-13}$$

7.2.1 Multiple Conduit Installations

The procedures outlined in this section can be used to design outlet erosion protection for multi-barrel culvert installations by replacing the multiple barrels with a single hydraulically equivalent hypothetical rectangular conduit. The dimensions of the equivalent conduit may be established as follows:

- 1) Distribute the total discharge, Q, among the individual conduits. Where all the conduits are hydraulically similar and identically situated, the flow can be assumed to be equally distributed; otherwise, the flow through each barrel must be computed.
- 2) Compute the Froude parameter $Q_i/D_{ci}^{2.5}$ (circular conduit) or $Q_i/W_i H_i^{1.5}$ (rectangular conduit), where the subscript "i" indicates the discharge and dimensions associated with an individual conduit.
- 3) If the installation includes dissimilar conduits, select the conduit with the largest value of the Froude parameter to determine the dimensions of the equivalent conduit.
- 4) Make the height of the equivalent conduit, H_{eq} , equal to the height, or diameter, of the selected individual conduit.
- 5) The width of the equivalent conduit, W_{eq} , is determined by equating the Froude parameter from the selected individual conduit with the Froude parameter associated with the equivalent conduit, $Q/W_i H_{eq}^{1.5}$.

Figure 7.2-1. Riprap apron schematic for culverts inline with the channel

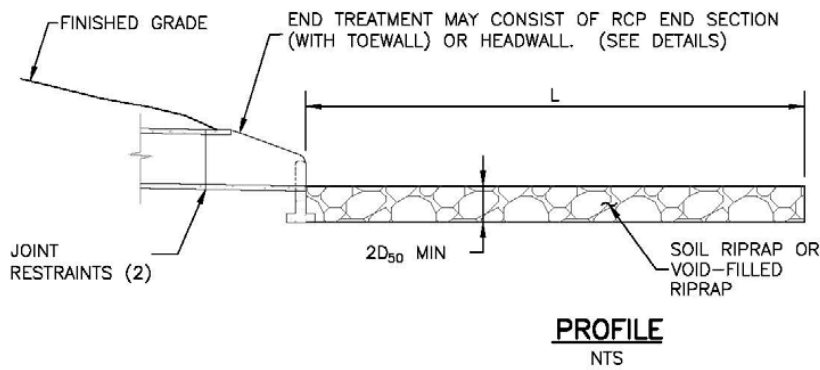
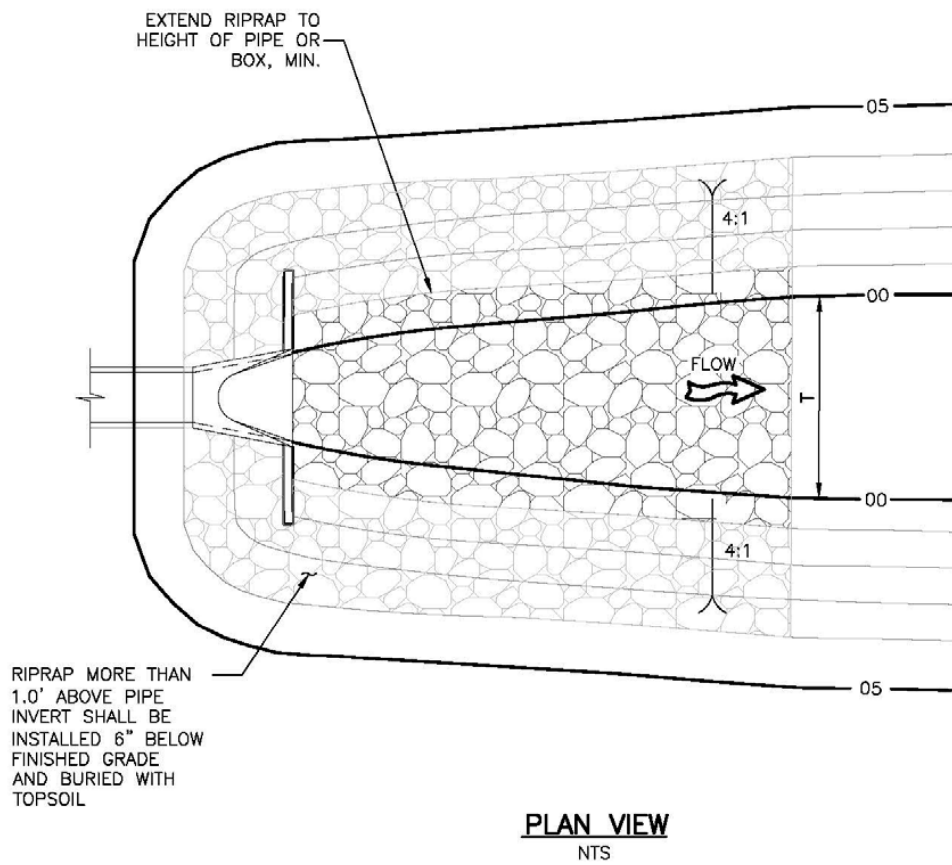

Figure 7.2-2. Expansion factor for circular conduits

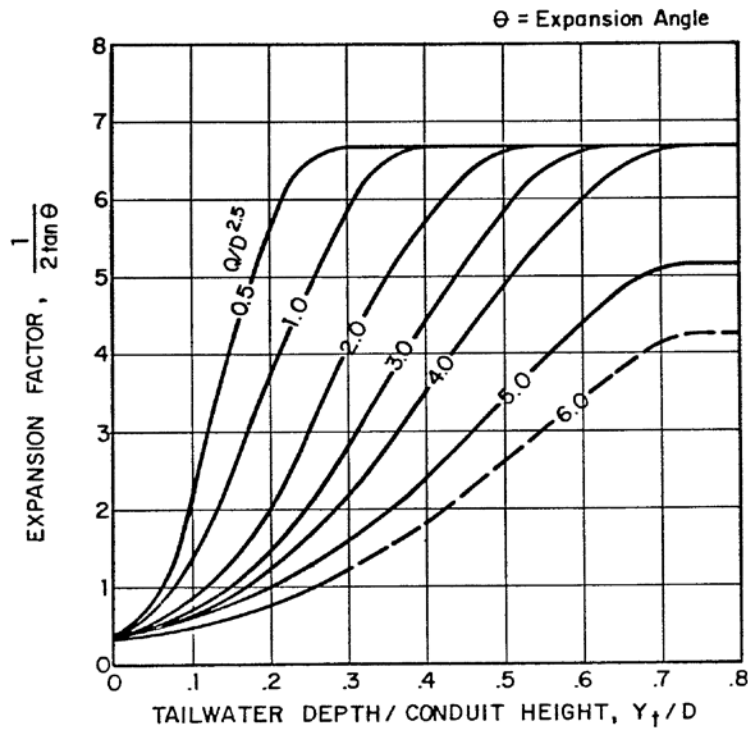
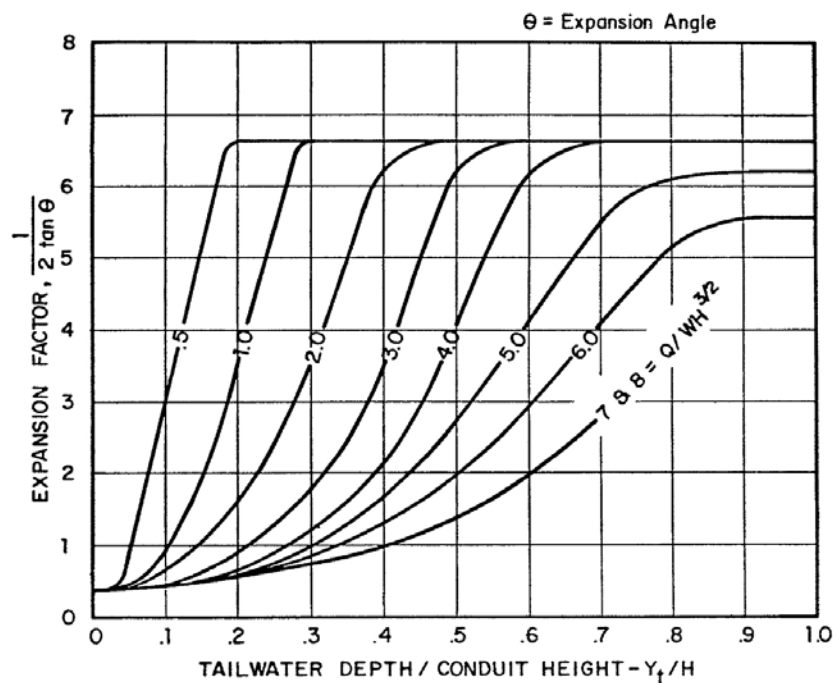

Figure 7.2-3. Expansion factor for rectangular conduits



7.3 Rock Sizing for Riprap Apron

Scour resulting from highly turbulent, rapidly decelerating flow is a common problem at conduit outlets. The following section summarizes the method for sizing riprap protection for both riprap aprons and low tailwater basins.

The required rock size may be selected from **Figure 7.2-2** for circular conduits and from **Figure 7.2-3** for rectangular conduits. **Figure 7.2-2** is valid for $Q/D_c^{2.5}$ of 6.0 or less and **Figure 7.2-3** is valid for $Q/WH^{1.5}$ of 8.0 or less. The parameters in these two figures are:

- 1) $Q/D^{1.5}$ or $Q/WH^{0.5}$ in which Q is the design discharge in cfs, D_c is the diameter of a circular conduit in feet, and W and H are the width and height of a rectangular conduit in feet.
- 2) Y_t/D_c or Y_t/H in Y_t is the tailwater depth in feet, D_c is the diameter of a circular conduit in feet, and H is the height of a rectangular conduit in feet. In cases where Y_t is unknown or a hydraulic jump is suspected downstream of the outlet, use $Y_t/D_t = Y_t/H = 0.40$ when using **Figures 7.3-1** and **7.3-2**.
- 3) The riprap size requirements in **Figures 7.3-1** and **7.3-2** are based on the non-dimensional parametric **Equations 9-14** and **9-15** (Steven, Simons and Watts 1971 and Smith 1975).

Circular culvert:

$$d_{50} = \frac{0.023Q}{Y_t^{1.2}D_c^{0.3}} \quad \text{Equation 9-14}$$

Rectangular culvert:

$$d_{50} = \frac{0.014H^{0.5}Q}{Y_tW} \quad \text{Equation 9-15}$$

These rock requirements assume that the flow in the culvert is subcritical. It is possible to use **Equations 9-14** and **9-15** when the flow in the culvert is supercritical (and less than full) if the value of D_c or H is modified for use in **Figures 7.3-1** and **7.3-2**. Whenever the flow is supercritical in the culvert, substitute D_a for D_c and H_a for H , in which D_a is defined as:

$$D_a = \frac{(D_c + Y_n)}{2} \quad \text{Equation 9-16}$$

Where the maximum value of D_a shall not exceed D_c , and:

$$H_a = \frac{(H + Y_n)}{2} \quad \text{Equation 9-17}$$

7.0 Energy Dissipation and Erosion Protection

Where the maximum value of H_a shall not exceed H , and:

D_a = parameter to use in place of D , in **Figure 7.3-1** when flow is supercritical, ft

D_c = diameter of circular culvert, ft

H_a = parameter to use in place of H in **Figure 7.3-2** when flow is supercritical, ft

H = height of rectangular culvert, ft

Y_n = normal depth of supercritical flow in the culvert, ft

Figure 7.3-1. Riprap erosion protection at circular conduit outlet (valid for $Q/D^{1.5} \leq 6.0$)

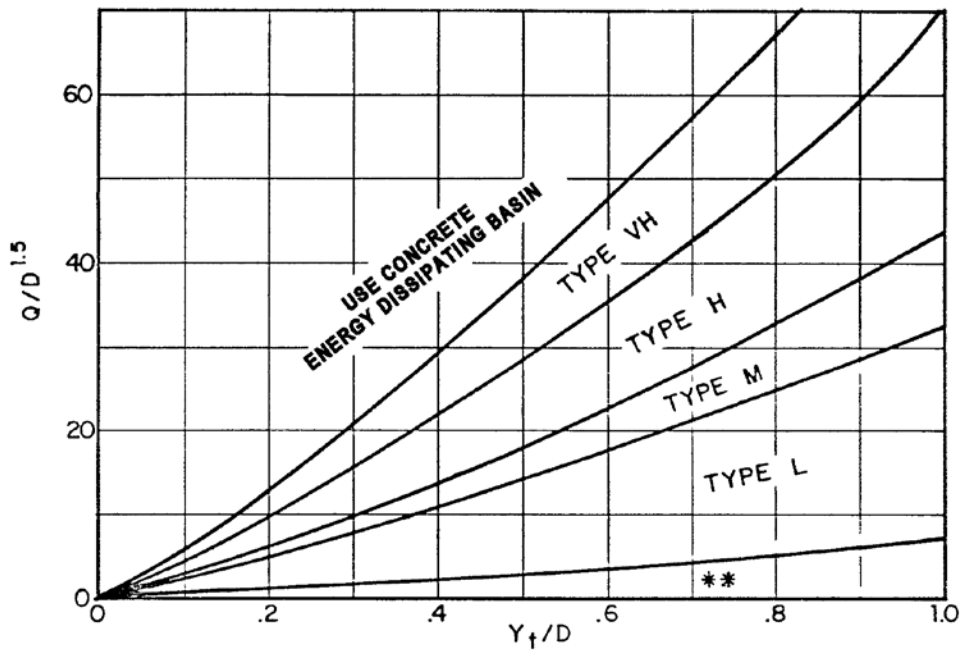

Use D_a instead of D whenever flow is supercritical in the barrel.

Figure 7.3-2. Riprap erosion protection at rectangular conduit outlet (valid for $Q/WH^{0.5} \leq 8.0$)

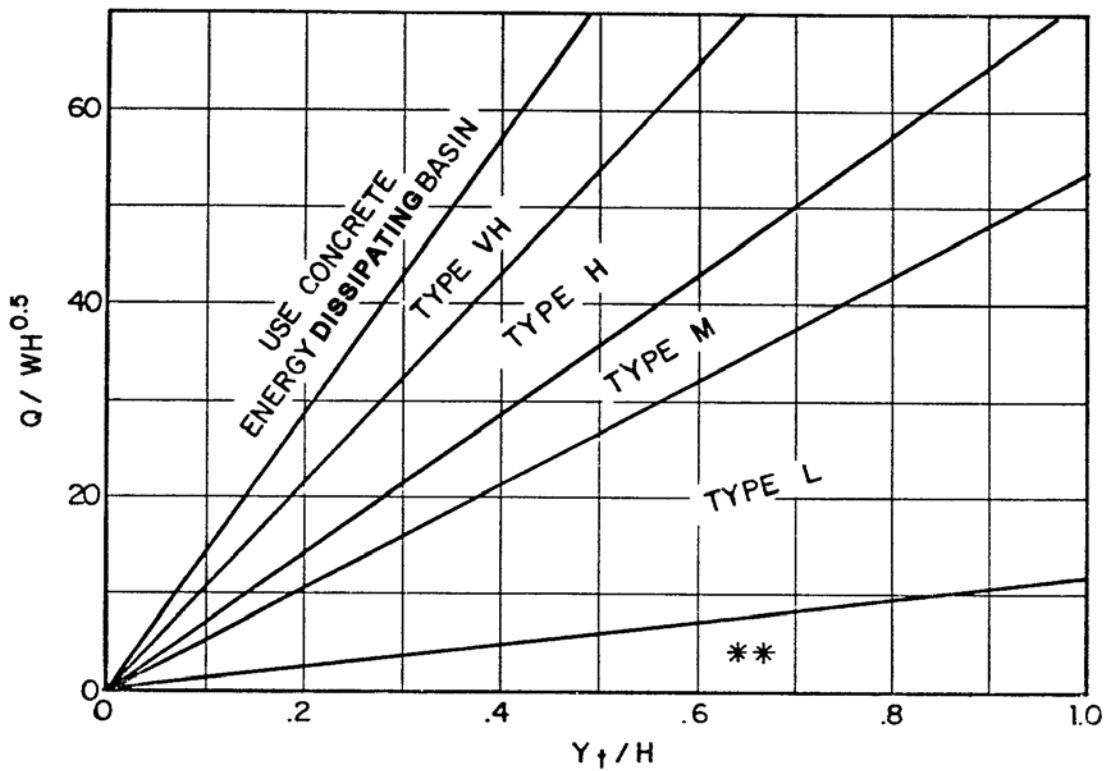

Use H_d instead of H whenever culvert has supercritical flow in the barrel.

Figure 7.3-3. Riprap and soil riprap placement and gradation (part 1 of 3)

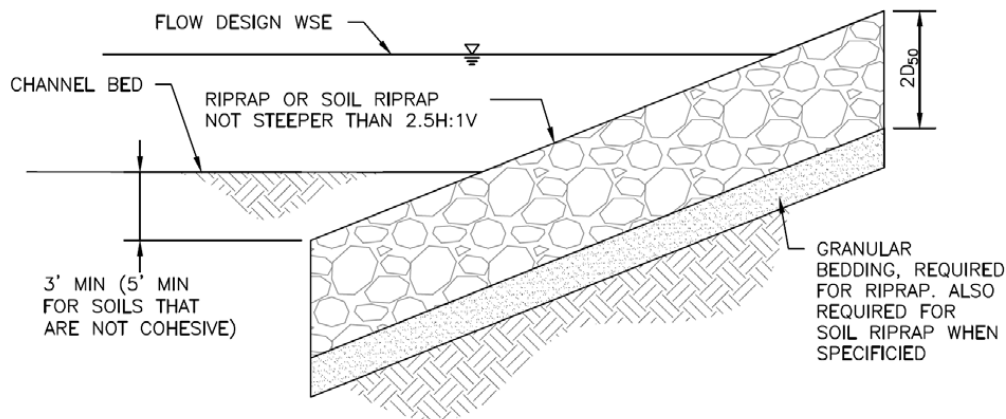

Riprap and Soil Riprap Placement and Gradation (Part 1 of 3)

Riprap Designation	% Smaller Than Given Size by Weight	Intermediate Rock Dimension (inches)	Mean Rock Size, D ₅₀ (inches)
Type M	70-100	21	12
	50-70	18	
	35-50	12	
	2-10	4	
Type H	70-100	30	18
	50-70	24	
	35-50	18	
	2-10	6	

Soil Riprap Notes:

- 1.) Elevation tolerances for the soil riprap shall be 0.10 feet. Thickness of soil riprap shall be no less than thickness shown and not more than two inches (2”) greater than the thickness shown.
- 2.) Where “soil riprap” is designated on the contract drawings, riprap voids are to be filled with native soil. The riprap shall be pre-mixed with the native soil. The soil used for mixing shall be native topsoil. The soil riprap shall be installed in a manner that results in a dense, interlocked layer of riprap with riprap voids filled completely with soil. Segregation of materials shall be avoided and in no case shall be combined material consist primarily of soil; the density and interlocking nature of riprap in the mixed material shall essentially be the same as if the riprap was placed without soil. Mix proportions and riprap gradations to be provided by the Design Engineer.
- 3.) Where specified typically as “buried soil riprap”, a surface layer of topsoil shall be placed over the soil riprap according to the thickness specified on the contract drawings. The topsoil surface layer shall be compacted to approximately 85% of maximum density and within two percentage points of optimum moisture in accordance with ASTM D698. Topsoil shall be added to any areas that settle.
- 4.) All soil riprap that is buried with topsoil shall be reviewed and approved by the Design Engineer prior to any topsoil placement.

Riprap and Soil Riprap Placement and Gradation (Part 2 of 3)

Gradation for Granular Bedding		
US Standard Sieve Size	Percent Passing by Weight	
	Type I CDOT Section 703.01	Type II CDOT Section 703.09 Class A
3"	-	90-100
1 1/2"	-	-
3/4"	-	20-90
3/8"	100	-
#4	95-100	0-20
#16	45-80	-
#50	10-30	-
#100	2-10	-
#200	0-2	0-3

Riprap and Soil Riprap Placement and Gradation (Part 3 of 3)

Thickness Requirements for Granular Bedding			
Riprap Designation	Minimum Bedding Thickness (inches)		
	Fine-Graded Soils ¹		Coarse-Graded Soils ²
	Type 1 (Lower Layer)	Type II (Upper Layer)	Type II
Type M	4	4	6
Type H	4	6	8
Type VH	4	6	8

Notes:

- 1.) May substitute one twelve inch (12") layer of Type II bedding. The substitution of one layer of Type II bedding shall not be permitted at drop structures. The use of a combination of filter fabric and Type II bedding at drop structures is acceptable.
- 2.) 50% or more by weight retained on the #40 sieve.

Chapter 10: References

Contents

1.0 References 1

1.0 References

Altitude Training Associates, 2008. *Stormwater Management During Construction: Best Management Practices for Construction in Waterways Training Program Student Manual*. www.udfcd.org

BHA Design Inc. and City of Fort Collins Utility Services, 2009. *Landscape Design Standards and Guidelines for Stormwater and Detention Facilities*

City of Fort Collins, 2011. *Development Construction Standards, Water Wastewater Stormwater*

City of Fort Collins, 2016. *Development Construction Standards, Water Wastewater Stormwater, Division 1 Technical Corrections*

City of Fort Collins, *FCMaps*

<http://gisweb.fcgov.com/HTML5Viewer/Index.html?viewer=FCMaps>

Code of the City of Fort Collins

Colorado Department of Public Health and Environment, Water Quality Control Division, 2007. *CDPS General Permit, Stormwater Discharges Associated with Construction Activity*.

Colorado Department of Public Health and Environment, Water Quality Control Division, 2017. *CDPS General Permit, Stormwater Discharges Associated with Municipal Separate Storm Sewer Systems (MS4s)*.

Colorado Oil and Gas Conservation Commission, *Regulations and Rule 1002*:

<http://cogcc.state.co.us/documents/reg/Rules/LATEST/1000Series.pdf>

Colorado State University (CSU). 2009. *Hydraulic Efficiency of Grate and Curb Inlets for Urban Storm Drainage*. Denver, CO: Urban Drainage and Flood Control District.

Federal Highway Administration (FHWA). 2009. *Urban Drainage Design Manual*. Hydraulic Engineering Circular 22. Washington, DC: Federal Highway Administration.

Guo, J.C.Y. 1999. *Streets Hydraulics and Inlet Sizing*: Water Resources Publications, Littleton, CO.

Guo, J.C.Y. 1992. *Technical Manual for Computer Model UDSEWER for Storm Sewer System Design*. Denver, CO: Department of Civil Engineering, University of Colorado at Denver.

Guo, J.C.Y. 1998a. Storm Sewer System Design and Flow Analysis Using the Personal Computer Model UDSEWER. Denver, CO: Urban Drainage and Flood Control District.

Guo, J.C.Y. 1998b. *Street Hydraulics and Inlet Sizing Using the Computer Model UDINLET*. Denver, CO: Urban Drainage and Flood Control District.

Guo, J.C.Y. 1999. *Storm Water System Design*. CE 5803, University of Colorado at Denver.

Guo, J.C.Y. 2000a. Design of Grate Inlets with a Clogging Factor. *Advances in Environmental Research* 4(3)181-186.

Guo, J.C.Y. 2000b. Street Storm Water Conveyance Capacity. *Journal of Irrigation and Drainage Engineering* 136(2)119-124.

Larimer County Soil Survey and information fact sheets, NRCS Soil Survey of Larimer County
https://www.nrcs.usda.gov/Internet/FSE_DOCUMENTS/nrcs144p2_061728.pdf

Land Use Code of the City of Fort Collins

Larimer County, 2016. *Urban Area Street Standards, Repealed and Reenacted, Effective April 1, 2007*

Renard, K.G., G.R. Foster, G.A. Weesies, D.K. McCool, and D.C. Yoder, coordinators, 1997. *Predicting Soil Erosion by Water: A Guide to Conservation Planning with the Revised Universal Soil Loss Equation*. U.S. Department of Agriculture, Agriculture Handbook 703. 384pp.
<http://ddr.nal.usda.gov/dspace/bitstream/10113/11126/1/CAT10827029.pdf>

Rossman, L. and Huber, W., *Storm Water Management Model Reference Manual, Volume 1 – Hydrology (Revised)*, US EPA Office of Research and Development, Washington, DC, EPA/600/R-15/162A, 2015

Urban Drainage and Flood Control District, 2016. *Urban Storm Drainage Criteria Manual Volume 1*

Urban Drainage and Flood Control District, 2016. *Urban Storm Drainage Criteria Manual Volume 2*

Urban Drainage and Flood Control District, 2010. *Urban Storm Drainage Criteria Manual Volume 3*

Wright Water Engineers, Inc. 2001. *Urban Storm Drainage Criteria Manual Volume 1 and 2*. Prepared for the Urban Drainage and Flood Control District

Urban Drainage and Flood Control District, 1999. *Urban Storm Drainage Criteria Manual Volume 3 - Best Management Practices*

1.0 References

U.S. Environmental Protection Agency (EPA), 2009. *Effluent Limitations Guidelines and Standards for the Construction and Development Point Source Category, Final Rule. December 1, 2009*. Federal Register, Part III Environmental Protection Agency, 40 CFR Part 450. 74 (229): 62997-63057.

Websoil Survey: [USDA National Cooperative Soil Survey](#).

Wischmeier, W.H. and D.D. Smith, 1965. *Predicting Rainfall-Erosion Losses From Cropland East of the Rocky Mountains*. Agriculture Handbook No. 282, US Dept. of Agriculture. Washington, DC.

Wischmeier, W.H. and D.D. Smith, 1978. *Predicting Rainfall Erosion losses: A Guide to Conservation Planning*. Agriculture Handbook No. 537, US Dept. of Agriculture. Washington, DC.